



E710

Next-Generation Compact Drive



COMPANY PROFILE

Starting from a major motor manufacturer, TECO has transformed into a business group with high competitiveness and globalized operation, spanning heavy electric equipment, home appliances, information technology, communications, key electronic components and parts, infrastructural engineering, financial investment, dining, and home delivery and other services.



In a global initiative aimed at expanding the business scope and creating a comprehensive marketing and service system, we are developing a new business model and implementing global operations to realize our corporate vision of becoming a world-class brand. We are utilizing innovative technologies and providing excellent services to achieve this goal.

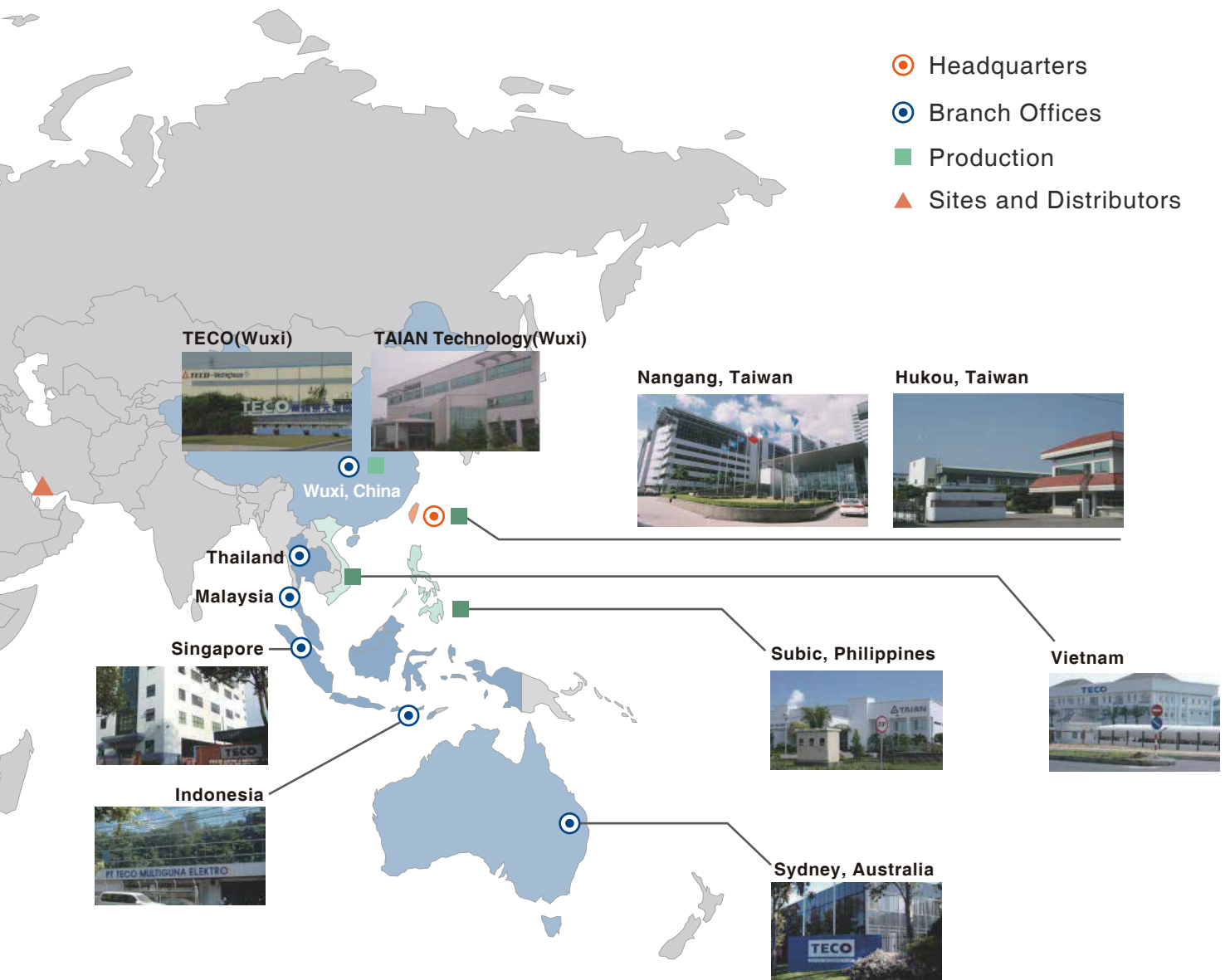

Next-Generation Compact Drive

E710

Miniature, multi-functional, stable and reliable, with more installation space and a stable, safe and reliable production environment.



1 Ultimate

Reduced size
Side by side installation



Disk reduction
50%



2 Easy to use

Easy installation
Simple adjustments

Rail mounting
Spring terminals

Buckle design
Copy modules

3 Superior

Multiple drivers
Superior performance



Multi-type PG feedback / Low motor noise

4 Stable, safe

Predictive diagnosis
Multiple protection

Advanced process
Demagnetization

Life prediction
Built-in filter

5 Complies with

Global sales
Responsible

UL , cUL , CE
RoHS , REACH

Ultimate space experience

Miniaturization

Space saving new technology and dual CPU design



Disk reduction
50%

E710

Ambient temperature -20~50°C
without derating

Seamless side-by-side installation

Significantly saves installation space,
installation costs, and looks clean and attractive



Install side-by-side or add dust-proof stickers:
ambient temperature -20~40°C without derating

Motor control algorithm improves quality and quantity

One machine with multiple controls , supports IM/PM/SynRM

Induction Motor



Easy installation

Permanent Magnet Motor



- High energy efficiency
- High design density
- Good response
- High starting torque
- Excellent frequency conversion and energy saving

Line-Start Synchronous Reluctance Motor



High energy efficiency

Excellent PM motor control

- Innovative vector control
- Algorithm to improve current efficiency

Rotating speed

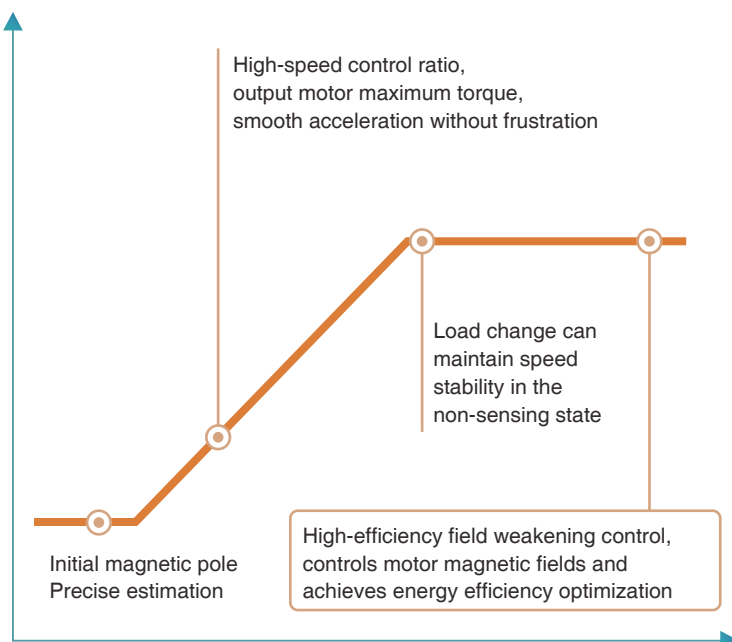

Motor Noise Reduction Technology

- Exclusive Soft PWM control technology reduces the radio frequency interference and motor noise.

Traditional PWM output

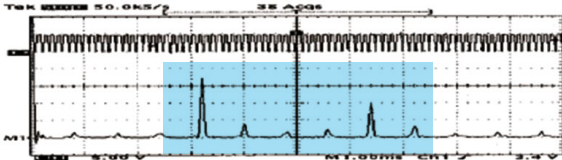

Soft PWM output

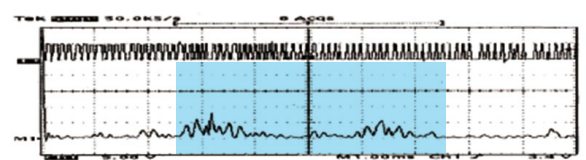

Built-in filter

- Models with built-in EMI filter comply with EN 61800-3 Class I environmental restrictions (C2 level) and reduce electromagnetic interference.

Smart Factory - Smartphone remote connection

- The optional LCD bluetooth panel remotely connects inverters with mobile phones so customers can conveniently monitor and adjust machines remotely.

Smart phones can be remotely connected to machines by installing the TECO Bluetooth operator (optional by project) on the panel to edit parameters and confirm monitoring information in real time.

- Monitor operating conditions
- Parameter setting
- Confirm error records
- Troubleshooting when errors occur



Safety Function

Integrated Safety Torque Off (STO), complies with:

- ◆ EN 60204-1 Category 0
- ◆ EN ISO 13849-1 Cat/PLd
- ◆ EN61508 SIL2
- ◆ EN62061 SIL CL2

Traditional



Integrated STO

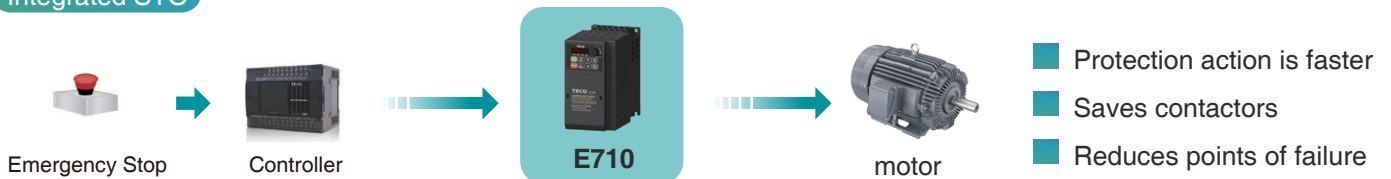

Easy to use

Communication accessories are easy to install, network interfaces and terminals coexist.



- Standard equipped with extendable LED panel
- Compatible with A510s LCD panel



- The fan easily disassembles, convenient for daily cleaning and maintenance.
- The buckle design is convenient for installation.
- Anti-dust stickers for added protection

- Spring-loaded quick-disconnect terminals saves installation time



- Track installation, efficient and convenient



DriveLink humanized compute

Users can use PC software to conveniently and efficiently edit E710 inverter parameters, save, and compare, etc. Improves efficiency of customer parameter settings and on-site debugging.

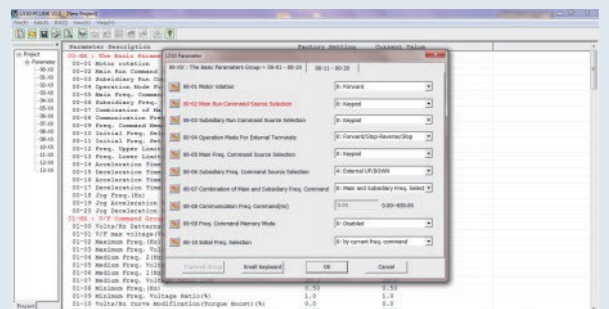

High reliability - automated production

Advanced production processes improve product reliability

- Automated processes improve mass production efficiency and stabilize product quality
- A range of PCB coatings improve product environmental tolerance

Complies with international standards

- Complies with European RoHS/REACH directives
- Complies with international UL/cUL/CE certification



Advanced equipment such as wave soldering furnaces
Lead-free processes



Automatic soldering robot arm ensures solder is error-free



One-stop assembly line
High efficiency and high productivity



Automatic coating production line improves product surface wear resistance

Pre-diagnosis of equipment failure

Service life prediction of main parts

Monitors the deterioration status of main part service life (fans, electrolytic capacitors, etc.) and immediately notifies replacement time to ensure continuous and stable operation of the equipment.



Fault warning and diagnosis functions



Inverter life prediction diagnosis



Multiple protection and alarm functions ensures stable operation of equipment



Running state



Protection of Motor
Real-time monitoring

Motor protection warning function

- Prevention of permanent magnet demagnetization (PM motor)
Advanced multi-stage voltage and current stall controls can maximize motor output and prevent PM motor demagnetization to prolong motor life
- Eccentric gap/rotor guide bar, end ring fracture malfunction/stator winding short circuit, open circuit detection (IM motor)

Wiring Diagram (E710 Standard S type) 403~430 / 202~220

The wiring diagram of the E710 inverter standard model (⊙ indicates the main circuit terminal / ○ indicates the control circuit terminal). The position and symbols of the wiring terminal socket of the E710 varies slightly depending on the model.

For descriptions of the main circuit terminals and control circuit terminals, please refer to the following chapters.

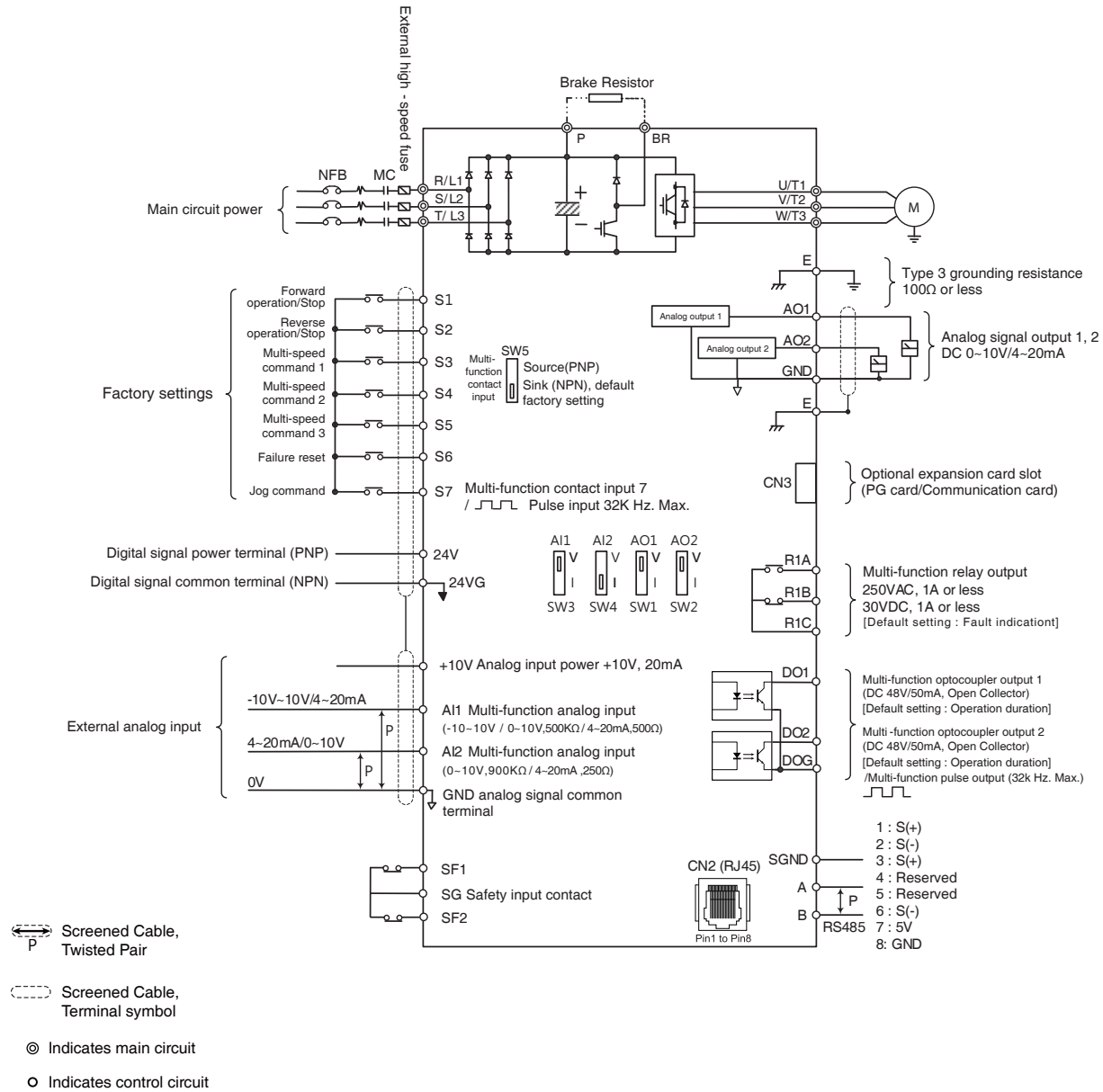

Note

- *1: Use SW5 to select between Sink (NPN, with 24VG common) or Source (PNP, with +24V common) for multi-function digital input terminals S1~S7.
- *2: Use SW3/SW4 to switch between voltage (0~10V) and current (4~20mA) input for Multi-function analog input 1/2 (AI1/AI2). Besides please also check parameter 04-00 for proper setting.
- *3: When S7 is used as pulse input, connecting an external resistor is unnecessary due to the built-in pull-up resistor.
- *4: The safety input contacts F1&F2 are short-circuited to the SG inverter for normal output. When using safety input, remove the short-circuit wires between F1-SG and F2-SG.
- *5: AO1/AO2 presets a 0~10V output can be set to voltage output (0~10V) or current output (4~20mA) through switch SW1/SW2 to match parameter settings.
- *6: When DO2 uses pulse output functions, pull-up resistance is recommended to be 200Ω.

Wiring Diagram (E710 Basic E type) 401~402 / 2P5~201

The wiring diagram of the E710 inverter basic model (⊙ indicates the main circuit terminal / ○ indicates the control circuit terminal). The position and symbols of the wiring terminal socket of the E710 varies slightly depending on the model.

For descriptions of the main circuit terminals and control circuit terminals, please refer to the following chapters.

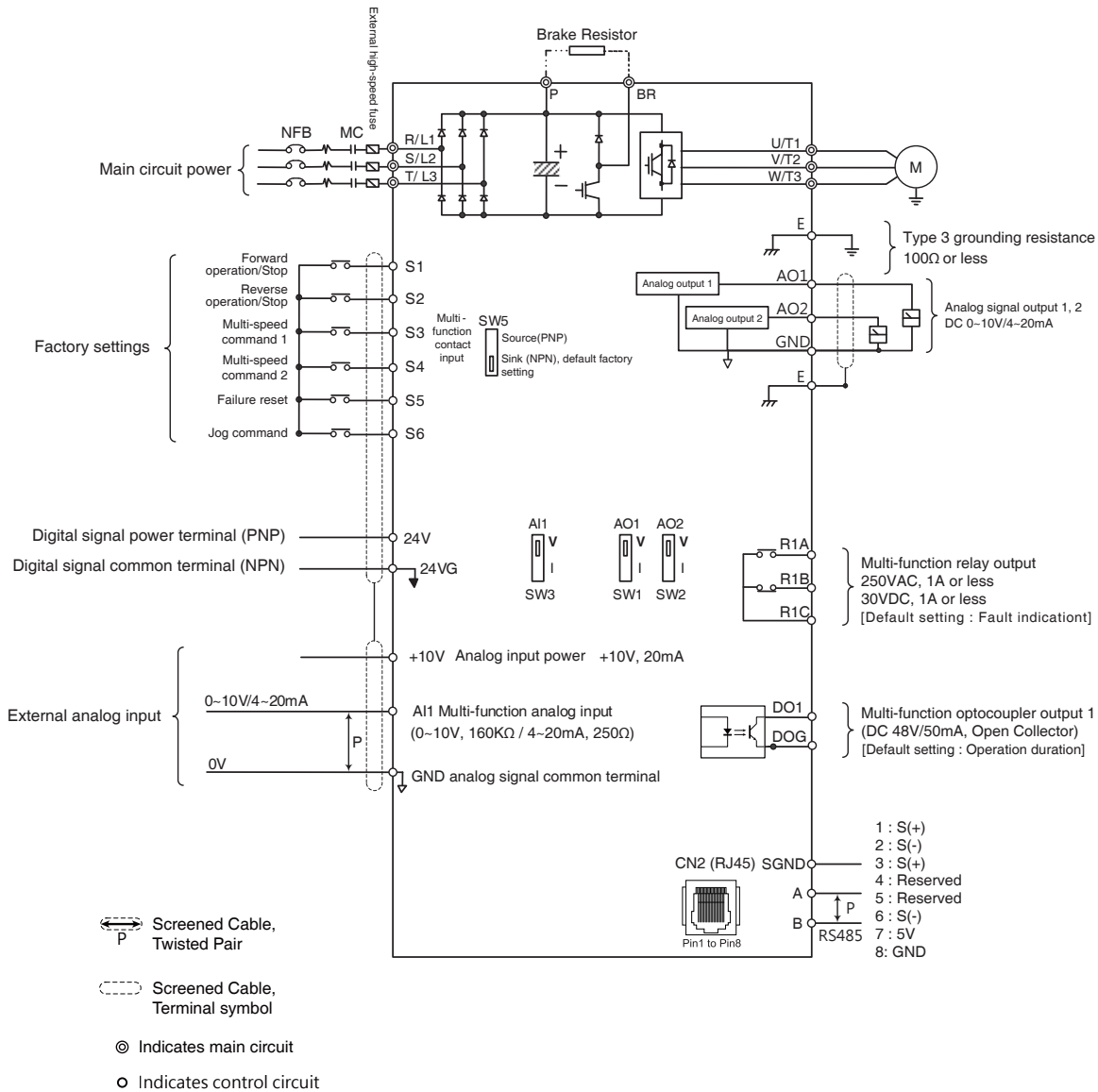

- Note
- *1: Use SW5 to select between Sink (NPN, with 24VG common) or Source (PNP, with +24V common) for multi-function digital input terminals S1~S6.
 - *2: Use SW3 to switch between voltage (0~10V) and current (4~20mA) input for Multi-function analog input 1 (AI1). Besides please also check parameter 04-00 for proper setting.
 - *3: AO1/AO2 presets a 0~10V output can be set to voltage output (0~10V) or current output (4~20mA) through switch SW1/SW2 to match parameter settings.

Catalog Number Identification

E710 - 2 01 - H 1 S F

Input Voltage	Horse Power	Type	Power Supply	E: Basic	Noise Filter
2 : 220V	P5 : 0.5HP 10 : 10HP	Blank : None	Blank :	401~402	Blank : None
4 : 440V	01 : 1.0HP 15 : 15HP	H : LED Keypad	Single/Three Phase	2P5~201	F : Built-in
	02 : 2.0HP 20 : 20HP		1 : Single-Phase	S: Standard	
	03 : 3.0HP 25 : 25HP		3 : Three-Phase	403~430	
	05 : 5.0HP 30 : 30HP			202~220	
	08 : 7.5HP				

General Specifications

Catalog No.	Input Voltage (VAC)	Horse Power	Motor Current	Output Current HD	Noise Filter		Frame No.
					Built-in	None	
E710-2P5-HE	Single/Three-Phase 200 ~ 240V +10% ~ -15% 50/60Hz	0.5	1.68	2.8		⊙	1
E710-201-HE		1	3.25	4.8		⊙	1
E710-202-HS		2	6.16	7.5		⊙	2
E710-203-HS		3	8.23	11		⊙	2
E710-2P5-H1EF	Single-Phase 200 ~ 240V +10% ~ -15% 50/60Hz	0.5	0.97	2.8	⊙		1
E710-201-H1EF		1	3.25	4.8	⊙		1
E710-202-H1SF		2	6.16	7.5	⊙		2
E710-203-H1SF		3	8.23	11	⊙		2
E710-205-H3S	Three-Phase 200 ~ 240V +10% ~ -15% 50/60Hz	5	14.48	17		⊙	2
E710-208-H3S		7.5	19.03	25		⊙	3
E710-210-H3S		10	25.60	33		⊙	4
E710-215-H3S		15	37.20	47		⊙	4
E710-220-H3S		20	50.34	60		⊙	5
E710-401-H3E	Three-Phase 380 ~ 480V +10% ~ -15% 50/60Hz	1	1.88	2.7		⊙	1
E710-402-H3E		2	3.56	4.2		⊙	1
E710-403-H3S		3	4.76	5.5		⊙	2
E710-405-H3S		5	8.37	9		⊙	2
E710-408-H3S		7.5	11	13		⊙	3
E710-410-H3S		10	14.8	17		⊙	3
E710-401-H3EF		1	1.88	2.7	⊙		1
E710-402-H3EF		2	3.56	4.2	⊙		1
E710-403-H3SF		3	4.76	5.5	⊙		2
E710-405-H3SF		5	8.37	9	⊙		2
E710-408-H3SF		7.5	11	13	⊙		3
E710-410-H3SF		10	14.8	17	⊙		3
E710-415-H3S		15	21.5	24		⊙	4
E710-420-H3S		20	29.1	31		⊙	4
E710-425-H3S		25	35.7	39		⊙	5
E710-430-H3S		30	42.3	45		⊙	5
E710-415-H3SF		15	21.5	24	⊙		4
E710-420-H3SF		20	29.1	31	⊙		4
E710-425-H3SF		25	35.7	39	⊙		5
E710-430-H3SF		30	42.3	45	⊙		5

General Specifications

		Standard S type(403~430/202~220)	Basic E type(401~402/2P5~201)
Control Characteristics		IM: V/F, V/F+PG, SLV, SV	IM: V/F, SLV
		PM: SV, SLV	PM: SLV
		SRM: PMA-SyRM-SLV, SyRM-SLV	-
Frequency	Frequency control range	0.01~599Hz	
	Starting torque	150%/3Hz(VF) , 150% / 0.5Hz (SLV)	
	Frequency setting resolution	Digital references: 0.01Hz	
		Analog references: 0.06Hz/60Hz	
	Frequency setting	Keypad: Set directly with ▲ ▼ keys or the VR on the keypad	
		External Input Terminas: AI1/AI2 (0~10V / 2~10V / 0~20mA / 4~20mA) input Multifunction input up/down function	
Setting frequency by communication method.			
Frequency limit	Lower and upper frequency limits 3 skip frequency settings.		
Speed control accuracy	V/F :±2~3%, SLV :± 1%		
Run	Operation set	Keypad run, stop button	
		External terminals: Multi-operation-mode2/3 wire selection, Jog operation	
		Run signal by communication method.	
Main Control Features	V / F curve setting	18 fixed curves and one customized curve	
	Carrier frequency	2~16KHz (default value : 4kHz)	
	Acceleration and deceleration control	2 off Acc / dec time parameters	
		4 off S curve parameters	
	Multifunction input	29 functions (refer to description on group3)	
	Multifunction output	21 functions (refer to description on group3)	
	Multifunction analog output	5 functions (refer to description on group4)	
Main features	Overload Detection,16 preset speeds,Auto-run, Acc/Dec Switch (2 Stages), PID control, Torque boost, Main/Alt run Command select, Main/Alt Frequency Command select, V/F start Frequency, Fault reset		
Display	LED	Display: Parameter / Parameter value / Frequency / Line speed / DC voltage / Output voltage / Output current / PID feedback / input and output terminal status / Heat sink temperature / Program Version / Fault Log.	
	LED Status Indicator	Run / Stop / Forward / Reverse ,and etc	
Protective functions	Overload Protection	The relays to protect the motor and the inverter. (150%/1min)	
	Over voltage	220V: >410V, 380V: >820V	
	Under Voltage	220V: <190V, 380V: <380V	
	Momentary Power Loss Restart	Inverter auto-restart after a momentary power loss.	
	Stall Prevention	Stall prevention for Acceleration/ Deceleration/ Operation.	
	Short-circuit output terminal	Electronic Circuit Protection	
	STO Functions	Standard S type (403~430/202~220):Output quick break	Basic E type (401~402/2P5~201):None
Other protection features	Protection for overheating of heat sink,The carrier frequency decreasing with the temperature function,fault output,reverse prohibit,prohibit for direct start after power up and error recovery , parameter lock up		
Communication control		Standard built-in RS485 communication (Modbus), One to one or One to many control.	
Environment	Operating temperature	Type IP20/NEMA 1 inside switchboard: Without dustproof sticker: -20~50° / With dustproof sticker: -20~40° Side-by-side installation: -20~40°C *De-rating: For usage between 50~60°C, there is a 2% decrease in current for every 1°C increase.	
	Storage temperature	-20~70°C	
	Humidity	95% RH or less (no condensation) (Compliance with IEC 60068 - 2-78)	
	Shock	10Hz ≤ f ≤ 57Hz : ±0.075mm Amplitude : 57Hz ≤ f ≤ 150Hz : 1.0G Acceleration: (Compliance with IEC60068-2-6)	
	Protection class	IP20 / NEMA1	
Certification		UL / cUL / CE / RoHS / REACH	

Dimensions

220V : 0.5~1HP / 440V : 1~2HP (IP20)

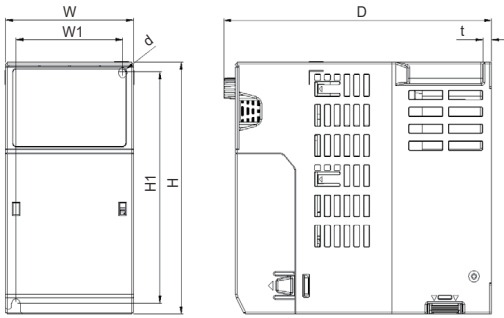

Catalog No.	Dimensions(mm)							Net Weight (kg)
	W	H	D	W1	H1	t	d	
E710-2P5-HE	72	142	150	60	130.5	5	M4	1.2
E710-201-HE	72	142	150	60	130.5	5	M4	1.2
E710-401-H3E	72	142	150	60	130.5	5	M4	1.2
E710-402-H3E	72	142	150	60	130.5	5	M4	1.2

220V : 0.5~1HP / 440V : 1~2HP (NEMA1)

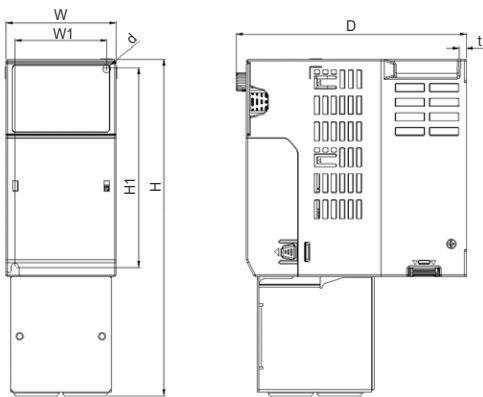

Catalog No.	Dimensions(mm)							Net Weight (kg)
	W	H	D	W1	H1	t	d	
E710-2P5-HE	72	220	150	60	130.5	5	M4	1.5
E710-201-HE	72	220	150	60	130.5	5	M4	1.5
E710-401-H3E	72	220	150	60	130.5	5	M4	1.5
E710-402-H3E	72	220	150	60	130.5	5	M4	1.5

220V : 2~5HP / 440V : 3~5HP (IP20)

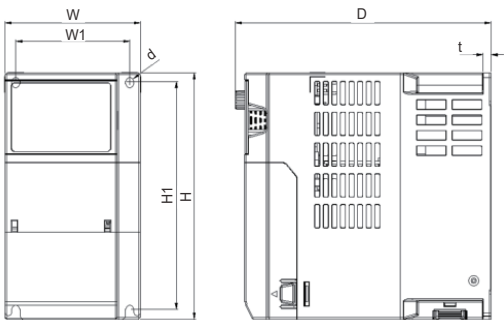

Catalog No.	Dimensions(mm)							Net Weight (kg)
	W	H	D	W1	H1	t	d	
E710-202-HS	87	157	164	73	145	5	M4	1.6
E710-203-HS	87	157	164	73	145	5	M4	1.6
E710-205-H3S	87	157	164	73	145	5	M4	1.6
E710-403-H3S	87	157	164	73	145	5	M4	1.6
E710-405-H3S	87	157	164	73	145	5	M4	1.6

220V : 2~5HP / 440V : 3~5HP (NEMA1)

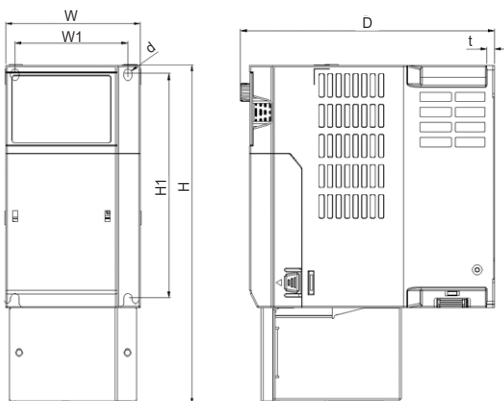

Catalog No.	Dimensions(mm)							Net Weight (kg)
	W	H	D	W1	H1	t	d	
E710-202-HS	87	220	164	73	145	5	M4	2
E710-203-HS	87	220	164	73	145	5	M4	2
E710-205-H3S	87	220	164	73	145	5	M4	2
E710-403-H3S	87	220	164	73	145	5	M4	2
E710-405-H3S	87	220	164	73	145	5	M4	2

Dimensions

220V : 8HP / 440V : 8~10HP (IP20)

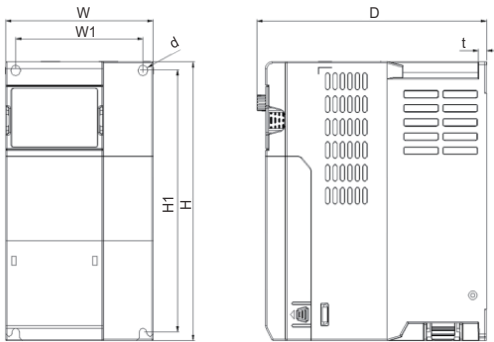

Catalog No.	Dimensions(mm)							Net Weight (kg)
	W	H	D	W1	H1	t	d	
E710-208-H3S	109	207	169	94	194.5	6	M4	2.3
E710-408-H3S	109	207	169	94	194.5	6	M4	2.3
E710-410-H3S	109	207	169	94	194.5	6	M4	2.3

*Please consult local sales personnel regarding filter sizes

220V : 8HP / 440V : 8~10HP (NEMA1)

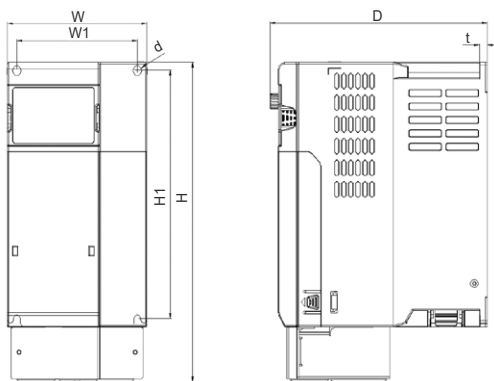

Catalog No.	Dimensions(mm)							Net Weight (kg)
	W	H	D	W1	H1	t	d	
E710-208-H3S	109	250	169	94	194.5	6	M4	2.3
E710-408-H3S	109	250	169	94	194.5	6	M4	2.3
E710-410-H3S	109	250	169	94	194.5	6	M4	2.3

220V : 10~15HP / 440V : 15~20HP (IP20)

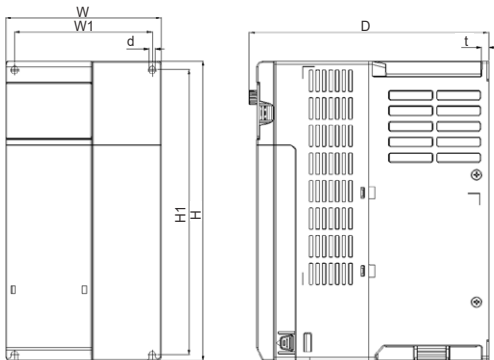

Catalog No.	Dimensions(mm)							Net Weight (kg)
	W	H	D	W1	H1	t	d	
E710-210-H3S	130	250	200	115	237.5	5.5	M5	4.2
E710-215-H3S	130	250	200	115	237.5	5.5	M5	4.2
E710-415-H3S	130	250	200	115	237.5	5.5	M5	4.2
E710-420-H3S	130	250	200	115	237.5	5.5	M5	4.2

220V : 10~15HP / 440V : 15~20HP (NEMA1)

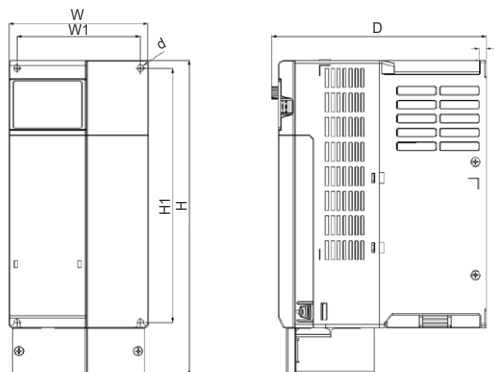

Catalog No.	Dimensions(mm)							Net Weight (kg)
	W	H	D	W1	H1	t	d	
E710-210-H3S	130	295	200	115	237.5	5.5	M5	6
E710-215-H3S	130	295	200	115	237.5	5.5	M5	6
E710-415-H3S	130	295	200	115	237.5	5.5	M5	6
E710-420-H3S	130	295	200	115	237.5	5.5	M5	6

Dimensions

220V : 20HP / 440V : 25~30HP (IP20)

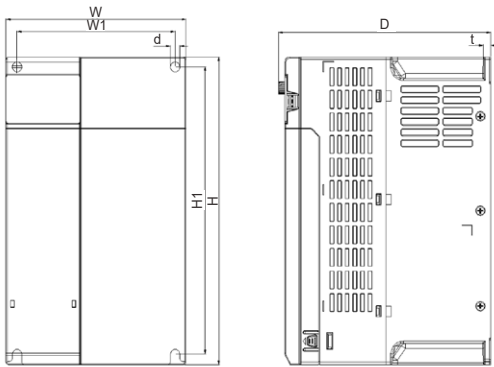

Catalog No.	Dimensions(mm)							Net Weight (kg)
	W	H	D	W1	H1	t	d	
E710-220-H3S	170	300	206.5	154	280	7	M8	6.5
E710-425-H3S	170	300	206.5	154	280	7	M8	6.5
E710-430-H3S	170	300	206.5	154	280	7	M8	6.5

220V : 20HP / 440V : 25~30HP (NEMA1)

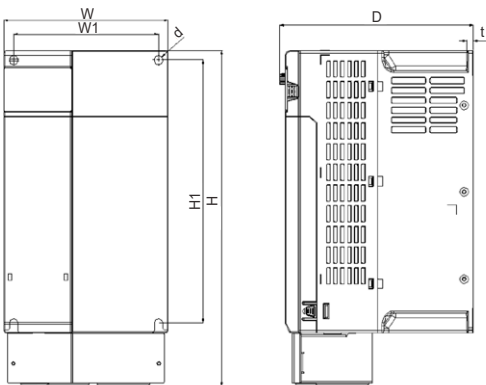

Catalog No.	Dimensions(mm)							Net Weight (kg)
	W	H	D	W1	H1	t	d	
E710-220-H3S	170	357	206.5	154	280	7	M8	8.5
E710-425-H3S	170	357	206.5	154	280	7	M8	8.5
E710-430-H3S	170	357	206.5	154	280	7	M8	8.5

■ Built-in filter type

220V : 0.5~1HP / 440V : 1~2HP

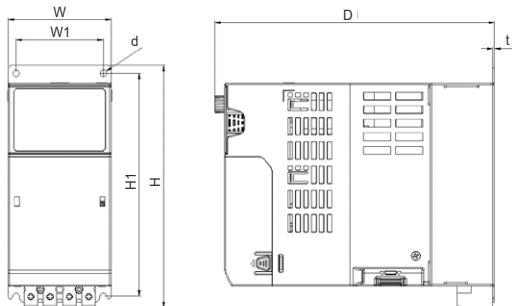

Catalog No.	Dimensions(mm)							Net Weight (kg)
	W	H	D	W1	H1	t	d	
E710-2P5-H1EF	72	169.5	195.5	60	156	1.2	M4	1.9
E710-201-H1EF	72	169.5	195.5	60	156	1.2	M4	1.9
E710-401-H3EF	72	169.5	195.5	60	156	1.2	M4	1.9
E710-402-H3EF	72	169.5	195.5	60	156	1.2	M4	1.9

220V : 2~3HP / 440V : 3~5HP

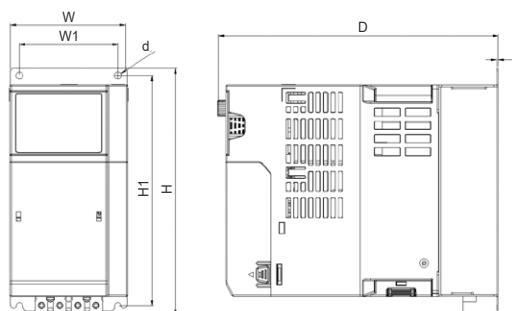

Catalog No.	Dimensions(mm)							Net Weight (kg)
	W	H	D	W1	H1	t	d	
E710-202-H1SF	87	184	207	73	171	1.2	M4	2.4
E710-203-H1SF	87	184	207	73	171	1.2	M4	2.4
E710-403-H3SF	87	184	207	73	171	1.2	M4	2.4
E710-405-H3SF	87	184	207	73	171	1.2	M4	2.4

Dimensions

440V : 7.5~10HP

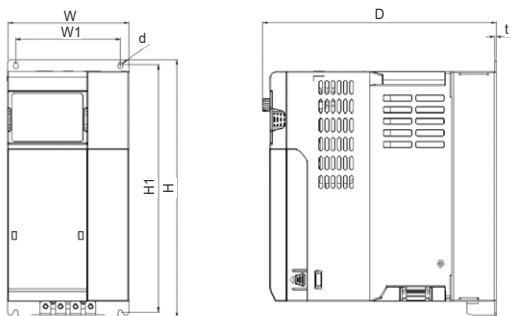

Catalog No.	Dimensions(mm)							Net Weight (kg)
	W	H	D	W1	H1	t	d	
E710-408-H3SF	109	232	210	94	222.5	1.2	M4	3.6
E710-410-H3SF	109	232	210	94	222.5	1.2	M4	3.6

440V : 15~20HP

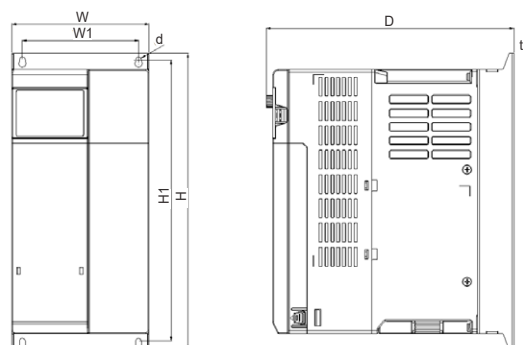

Catalog No.	Dimensions(mm)							Net Weight (kg)
	W	H	D	W1	H1	t	d	
E710-415-H3SF	130	280	234.5	110	266	1.5	M5	6.2
E710-420-H3SF	130	280	234.5	110	266	1.5	M5	6.2

440V : 25~30HP

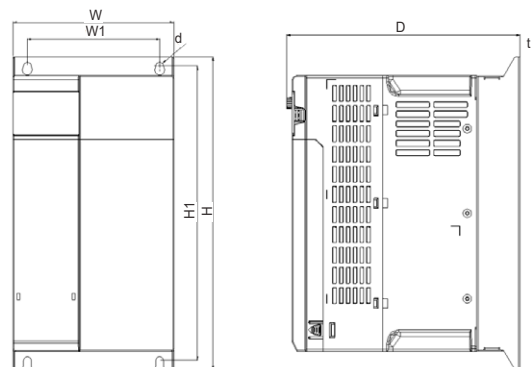

Catalog No.	Dimensions(mm)							Net Weight (kg)
	W	H	D	W1	H1	t	d	
E710-425-H3SF	174	340	254	144	320.5	1.5	M8	9
E710-430-H3SF	174	340	254	144	320.5	1.5	M8	9

Accessories

Accessories	Catalog No.	Description
710 Series Copy Module	JN7-CU	<p>Copy functions: When the same parameters are to be set for several E710 inverters of the same model, the parameters of one inverter can be preset and the copy module that saves the set parameters can be connected and the parameters can be copied to other machines through the copy module, which can reduce the need to repeat manual settings.</p> <p>Simple panel functions: cannot be used as a panel, please refer to the inverter's instruction manual for specific operations.</p>
Profibus DP Communication Module	JN5-CM-PDP	Development of the JN5-CM-PDP module is for Profibus-dp factory automation applications.
TCP-IP Communication	JN5-CM-TCPIP	For communicating with devices such as inverters/servo drives that support RS485 communication protocols to achieve remote control.
DeviceNet Communication	JN5-CM-DNET	Applicable in automatic control systems using DeviceNet industrial network communication protocols and enables E710 series inverters without DeviceNet functions to run on the DeviceNet network.
CANopen Communication	JN5-CM-CAN	Applicable in automatic control systems adopting CANopen industrial network communication protocols, so that E710 series inverters can run on the CANopen network.
RJ45 to USB Communication cable (1.8m)	JN5-CM-USB	Converts USB communication formats to RS485 communication formats, allowing communication control between the inverter and PC (or other control equipment with USB interfaces), diversifying inverter control.
Profinet Communication Card	JN7-CMCS-PFNET	Applicable in automatic control systems adopting Profinet industrial network communication protocols, so that E710 series inverters can run on the Profinet network.
OPC UA Communication Card	JN7-CMCS-OPCUA	Applicable in automatic control systems adopting OPC UA industrial network communication protocols, so that E710 series inverters can run on the OPC UA network, and support data exchange with upper-level monitoring systems.
EtherCAT Communication Card	JN7-CMCS-ECAT	Applicable in automatic control systems adopting EtherCAT industrial network communication protocols, so that E710 series inverters can run on the EtherCAT network, achieving high-speed and real-time communication control.
MODBUS TCP Communication Card	JN7-CMCS-MBTCP	Applicable in automatic control systems adopting MODBUS TCP industrial network communication protocols, so that E710 series inverters can run on the MODBUS TCP network.
Ethernet IP Communication Card	JN7-CMCS-EIP	Applicable in automatic control systems adopting EtherNet/IP industrial network communication protocols, so that E710 series inverters can run on the EtherNet/IP network.
BACnet IP Communication Card	N7-CMCS-BACIP	Applicable in building automation systems adopting BACnet IP industrial network communication protocols, so that E710 series inverters can run on the BACnet IP network and integrate with building management systems.
EtherCAT Communication Card	JN7-CMHI-ECAT	Applicable in automatic control systems adopting EtherCAT industrial network communication protocols, so that E710 series inverters can run on the EtherCAT network, achieving high-speed and real-time communication control.
CANopen Communication Card	JN7-CMHI-CAN	Applicable in automatic control systems adopting CANopen industrial network communication protocols, so that E710 series inverters can run on the CANopen network.
Profibus DP Communication Card	JN7-CMHI-PDP	Development of the JN7-CMHI-PDP communication card is for Profibus DP factory automation applications.
TCP-IP Communication Card	JN7-CMI-TCPIP	For communicating with devices such as inverters/servo drives that support RS485 communication protocols to achieve remote control.
PG Feedback Card	JN7-PG-L	PG feedback card dedicated for IM (induction motor), available in Line Driver type and Open Collector type output options.
Bluetooth Keypad	JN5-OP-BTH	For wireless remote connection to control the inverter, which can monitor the real-time status and diagnose faults quickly. Note: With the smartphone APP "BT DriveLink", it can be downloaded from Apple APP Store or Google Play.

Accessories

Copy module

JN7-CU



Features

- ▲ It is possible to copy the inverter parameter settings and write them to other inverters.
- ▲ Standard RJ45 network cable

Communication module

Profibus DP 、 TCP-IP 、 DeviceNet 、 CANopen



Features

- ▲ After corresponding products pass through the inverter RS485 interface, the inverter can satisfy the following communication protocols: Profibus DP, TCP-IP, DeviceNet, CANopen

Cable

RJ45 to USB

JN5-CM-USB	1.8 meters
-------------------	-------------------



Features

- ▲ Equipped with TECO computer software's exclusive connection cable. The inverter parameters can be edited through computers.

Built-in option card

Profibus DP

CANopen

Ethernet/IP

EtherCAT

TCP-IP

Profinet

OPC UA

Modbus TCP

BACnet IP

E710 industrial applications

- Food machinery
- Packaging and printing
- Fan and water pump
- Woodworking machinery
- Plastic machinery
- Metal processing
- Electronics
- Lithium batteries



Logistics and transportation



Textile machinery



Solar energy



Distributor



TECO Electric & Machinery Co., Ltd.

10F, No.3-1, Park St., Nan-Kang, Taipei 115, Taiwan

TEL : 886-2-6615-9111 FAX : 886-2-6615-0933 E-mail : ICS@teco.com.tw

www.teco.com.tw

Specifications covered in this brochure may be subject to change without notice.

