



F510

Enhanced / Waterproof
Fan & Pump Drive



F510

Mechanical Features

F510 realizes modular design, not only for applications of high protection level, but also for maintaining equipment inclusive of Hot plug display, communication card, removable fan, and etc...

Enclosure



IP20/IP21/NEMA1



IP55/NEMA 12

01

Hand/Auto/Off

Hand/Auto selection is a very convenient function when system failure, test and inspection. F510 provides friendly user interface of Hand/Auto selection. To get this function by using optional HOA digital operator.





Pump Cascade Control

- Possess constant pressure control technology.
- Provide quick parameter setting, favorable for most of water supply applications.
- Pump Cascade Control via optional pump card.

1 to 8 pump card is available for a larger water supply and constant pressure applications. It is sophisticated in water supply industry by built-in PID controller and simple PLC of the advantages of drive.

F510 series provides variable frequency power to realize the continuously variable speed of pump, and keep the pressure stable by built-in PID controller. 1 to 8 pump option card can control with up to 8 pumps.



**PUMP Card
1 to 8**

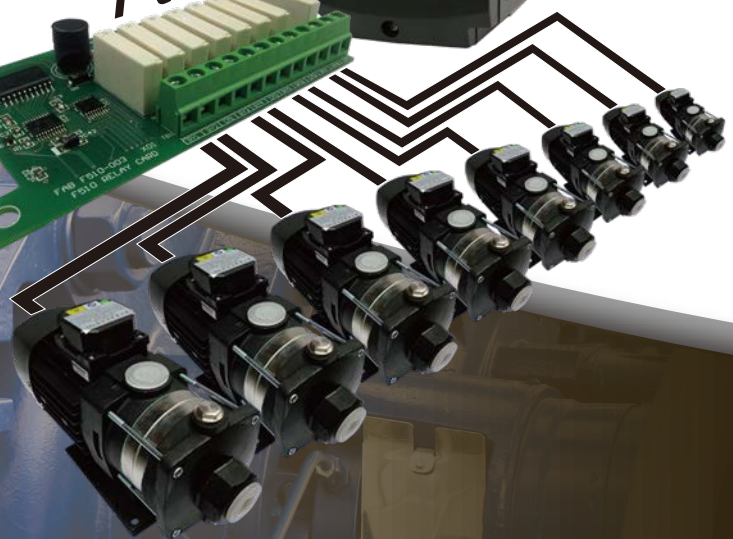
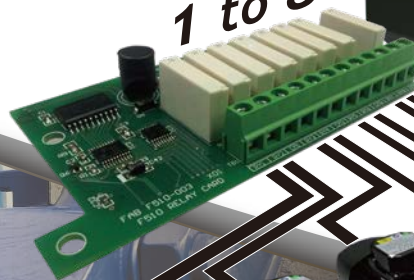

F510

Energy Efficient
Pump Control

Excellent Pump Control

Built-in multi-pump control mode. According to the load of water supply system, use intelligent control to coordinate pumps. It distributes running hours evenly across master and slave pumps to increase system efficiency and extend the life of drive.

Blockage Inspection

F510 can detect clog of pump and give alarm to prevent overload pressure to damage pipes.

Sleep Mode

Sleep mode saves energy by detecting when flow is low or zero. It can stop system to extend the life of drive.

Dry Pump Protection

F510 can evaluate the system pressure and detect pump running dry. It will shut off pump immediately to protect it from heat and friction damage.

Effective Harmonic Suppression

Effectively suppress harmonics with a built-in reactor*
Complies with EN61000-3-12 standard (THDi < 48%)



Before using F510
Harmonics not improved
THDi \geq 100%

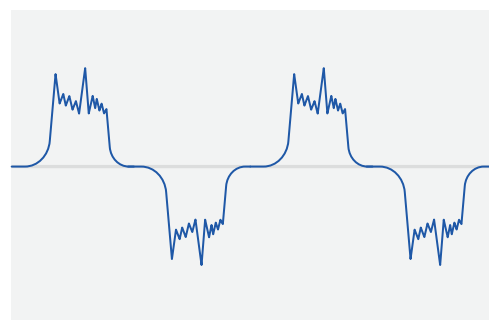

With F510
Harmonics effectively improved
THDi 48%

*Available in lower harmonic models. For details, please refer to Model Name Explanation.

F510

High Efficient Fan Control

With hardware safe torque off function and fire override mode for emergency.



Fire Override Mode

This feature is crucial for ensuring smoke extraction from building by air conditioner or fume extractor. In Fire mode, the drive will be used in full load operation as either forward or reverse direction and ignore all software protection until trigger hardware protection or drive damaged, to achieve the requirements of smoke extraction and reduce smoke damage to human as possible.

Skip Frequency

F510 can avoid resonance by quick parameter setting. Preventing mechanical damage to system and fans.

Robust Design

- PCB coating for all series to against harsh environment, meet IEC 60721-3-3 Class 3C2 standard.



- Vibration-resistant structure - Wire cable for C/B and M/B



- External heat sink for better cooling capability.
- The air flow and all PCB board can be fully isolated to prevent any dust or oil mist penetrate.

F510

Communication Network Protocol

Advanced network functions for building automation inclusive of BACnet , Metasys N2 and Modbus.

F510 can reduce the cost of installing automatic central air conditioning system.

METASYS is a communication protocol developed by Johnson Controls Inc. It is according to the actual needs of user and manager in building. Metasys N2 is easy to install, use, and adjust. System maintenance becomes very convenient. Metasys N2 may also collect, record, preserve and manage important message and data of the system, to achieve the best automatic management and energy saving effect.





has become a defacto standard communication protocol, and it is now amongst the most commonly available means of connecting industrial electronic devices.



is a communications protocol for building automation and control networks. It is an ASHRAE, ANSI, and ISO standard protocol. BACnet was designed to allow communication of building automation and control systems for applications such as heating, ventilating, and air-conditioning control, lighting control, access control, and fire detection systems and their associated equipment. The BACnet protocol provides mechanisms for computerized building automation devices to exchange information, regardless of the particular building service they perform.



Ultra Low Motor Noise

Soft PWM technology reduces common-mode voltage to restrain EMI and make motor noise down significantly.

Traditional PWM modulation method

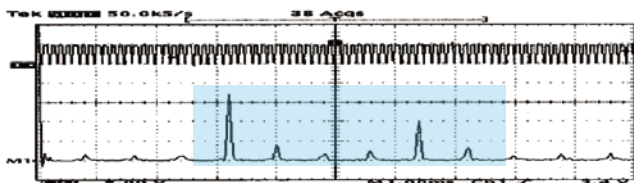

Unique Soft PWM modulation technology lowers the audible motor noise for quieter industrial environment.

Soft PWM modulation method

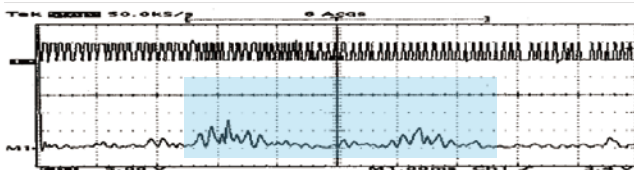

Permanent-Magnet Motor Control Technology

Permanent-magnet motor control technology avoids energy wasting. PM motor with high efficiency rises importance for present trend of energy saving and emission reduction.

Conformity To Global Standards

Conformity to RoHS directive and international recognized certification.

RoHS

UL/cUL approval and CE/RCM certification.



F510

Saving Energy

The issue of saving energy and emission reduction become popular in recent years. The importance of relative technologies grows as time. F510 provides various technologies of saving energy.

RTC Function / Simple PLC

Automatic control has been mainstream. It is not only saving human resource cost, but also handling system load more efficiently. To adjust load to avoid unnecessary expense by built-in simple PLC with Real Time Clock Function. It can modulate load easily to achieve the purpose of daylight saving.

※ The RTC function is only for LCD keypad.

Automatic Energy Saving Function

F510 can adjust to the optimum output voltage, and lower the output current of the drive according to the load automatically. The output power changes by the load proportion. In light duty, the AES has highest efficiency.



Support Communication Card/ IO Expansion Card/ DC24V Power Card (Only IP20 models supported)

Expansion Slot 1 (CN3)

- For 1-8 pump card installation. Catalog No.: JN5-IO-8DO. For larger water supply and constant pressure applications, and can control with up to 8 pumps.
- For DC24V power card installation. Catalog No.: JN5-PS-DC24V, to communicate with inverter, and setup or copy the parameter without using the main power.

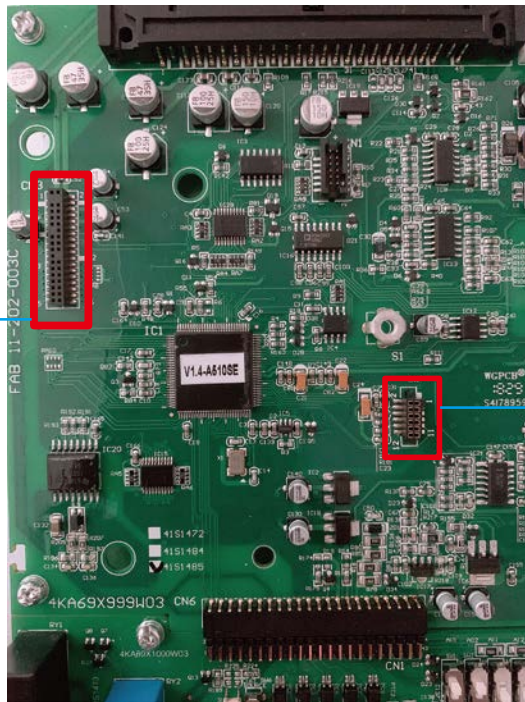

Expansion Slot 1 (CN2)

- For communication card installation. Please refer to accessories page for detail specification. It can improve the support of the upper controller communication protocol.
- For IO expansion card installation. Catalog No.: JN5-IO-2DO1AI, to add one relay, one transistor and one analog output with -10V ~ 10V/ 4~20mA.

Built-in STO function

With integrated Safety Torque Off (STO) function, complies with:

- EN ISO 13849-1 Cat/PLd
- EN61508 SIL2
- EN60204-1 Category 0
- EN62061 SIL CL2

It can save contactor's cost and install space, and provide quick and reliable protection.

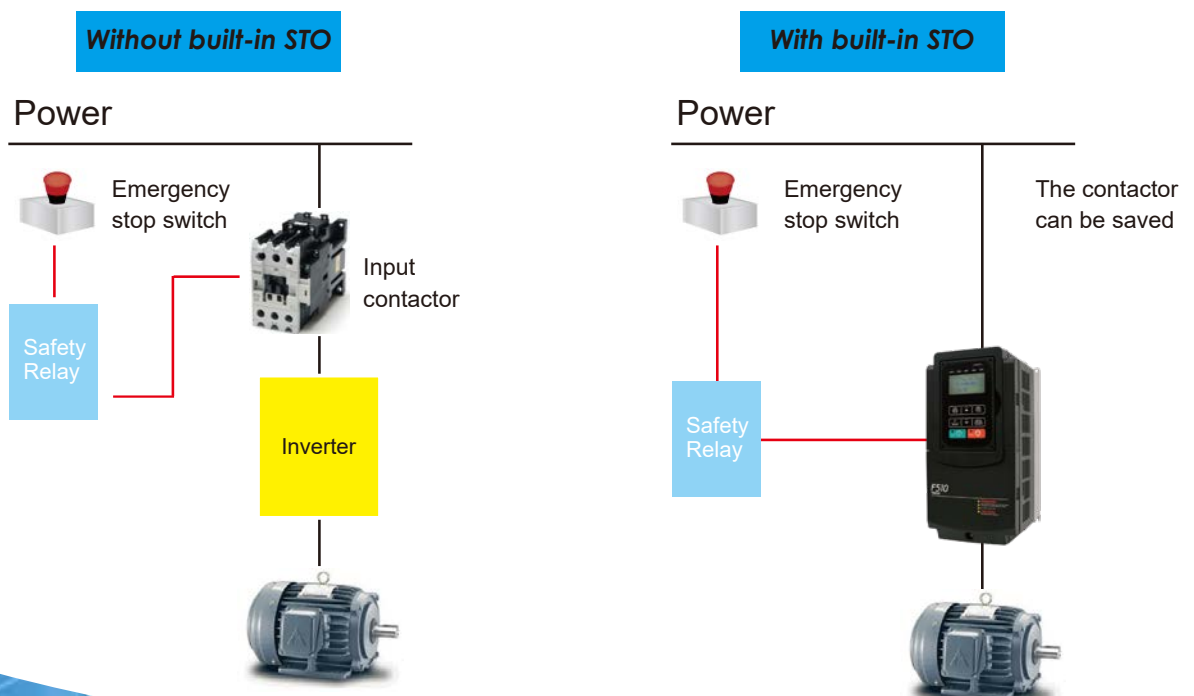

Basic Specifications (IP20 models)

200V Class

Inverter Capacity (HP)		1	2	3	5	7.5	10	15	20	25	30	40	50	60	75	100	125	150	175	
Output Rated	Rated Output Capacity (KVA)	1.9	2.9	4.0	5.5	8	11.4	15.2	21.3	26.2	30	41.9	52.5	64.3	76.2	95.2	119	152	171	
	Rated Output Current (A)	5.0	7.5	10.6	14.5	22	30	42	56	69	80	110	138	169	200	250	312	400	450	
	Maximum Applicable Motor	(HP)	1	2	3	5	7.5	10	15	20	25	30	40	50	60	75	100	125	150	175
		(KW)	0.75	1.5	2.2	3.7	5.5	7.5	11	15	18.5	22	30	37	45	55	75	90	110	130
	Maximum Output Voltage (V)	Three Phase, 200V~240V																		
Maximum Output Frequency (Hz)	Based on parameter setting 0.1~599.0 Hz																			
Input Power	Rated Voltage, Frequency	1-Phase/3-Phase		Three Phase, 200V~240V , 50/60 Hz																
	Allowable Voltage Fluctuation	-15% ~ +10%																		
	Allowable Frequency Fluctuation	±5%																		
Braking Transistor	Built-in										Option (Braking Module)									
DC reactor	None			Option												Built-in				
EMC Filter	Option																			
Frame	1		2		3		4		5		6		7		8					

400V Class

Inverter Capacity (HP)		1	2	3	5	7.5	10	15	20	25	30	40	50	60	75	100	125	150	175	215	250	300	375	425	535	670	800			
Output Rated	Rated Output Capacity (KVA)	2.6	3.1	4.1	7	8.4	13	18	24	28.9	34	41	55	67	78	110	125	158	190	225	250	331	392	445	525	640	731			
	Rated Output Current (A)	3.4	4.1	5.4	9.2	12.1	17.5	23	31	38	44	58	73	88	103	145	168	208	250	296	328	435	515	585	700	875	960			
	Maximum Applicable Motor	(HP)	1	2	3	5	7.5	10	15	20	25	30	40	50	60	75	100	125	150	175	215	250	300	375	425	535	670	800		
		(KW)	0.75	1.5	2.2	3.7	5.5	7.5	11	15	18.5	22	30	37	45	55	75	90	110	132	160	185	220	280	315	400	500	600		
	Maximum Output Voltage (V)	Three Phase, 380V~480V																												
Maximum Output Frequency (Hz)	Based on parameter setting 0.1~599.0 Hz																													
Input Power	Rated Voltage, Frequency	Three Phase, 380V~480V , 50/60 Hz																												
	Allowable Voltage Fluctuation	-15% ~ +10%																												
	Allowable Frequency Fluctuation	±5%																												
Braking Transistor	Built-in														Option (Braking Module)															
DC reactor	None		Option												Built-in				Option											
EMC Filter	Built-in														Option															
Frame	1		2		3		4		5		6		7		8		9													

Notes :

1. Based on the standard 4-pole induction motor. Selecting inverter must have a higher output current rating than motor.
2. The maximum output frequency of each control mode is different, please refer to user manual for more details.
3. IP21 models are available for frame 1 to frame 5, if necessary, please contact with our sales.

Basic Specifications (IP55 models)

400V Class

Inverter Capacity (HP)		1	2	3	5	7.5	10	15	20	25	30	40	50	60	75	100	
Output Rated	Rated Output Capacity (KVA)	2.6	3.1	4.1	7	8.4	13	18	24	28.9	34	41	55	67	78	110	
	Rated Output Current (A)	3.4	4.1	5.4	9.2	12.1	17.5	23	31	38	44	58	73	88	103	145	
	Maximum Applicable Motor	(HP)	1	2	3	5	7.5	10	15	20	25	30	40	50	60	75	100
		(KW)	0.75	1.5	2.2	3.7	5.5	7.5	11	15	18.5	22	30	37	45	55	75
	Maximum Output Voltage (V)	Three Phase, 380V~480V															
Maximum Output Frequency (Hz)	Based on parameter setting 0.1~400.0 Hz																
Input Power	Rated Voltage, Frequency	Three Phase, 380V~480V , 50/60 Hz															
	Allowable Voltage Fluctuation	-15% ~ +10%															
	Allowable Frequency Fluctuation	±5%															
Braking Transistor	Built-in									Option (Braking Module)							
DC reactor	Built-in																
EMC Filter	Built-in														Option		
Frame	1			2			3			4			5				

Catalog Number Identification

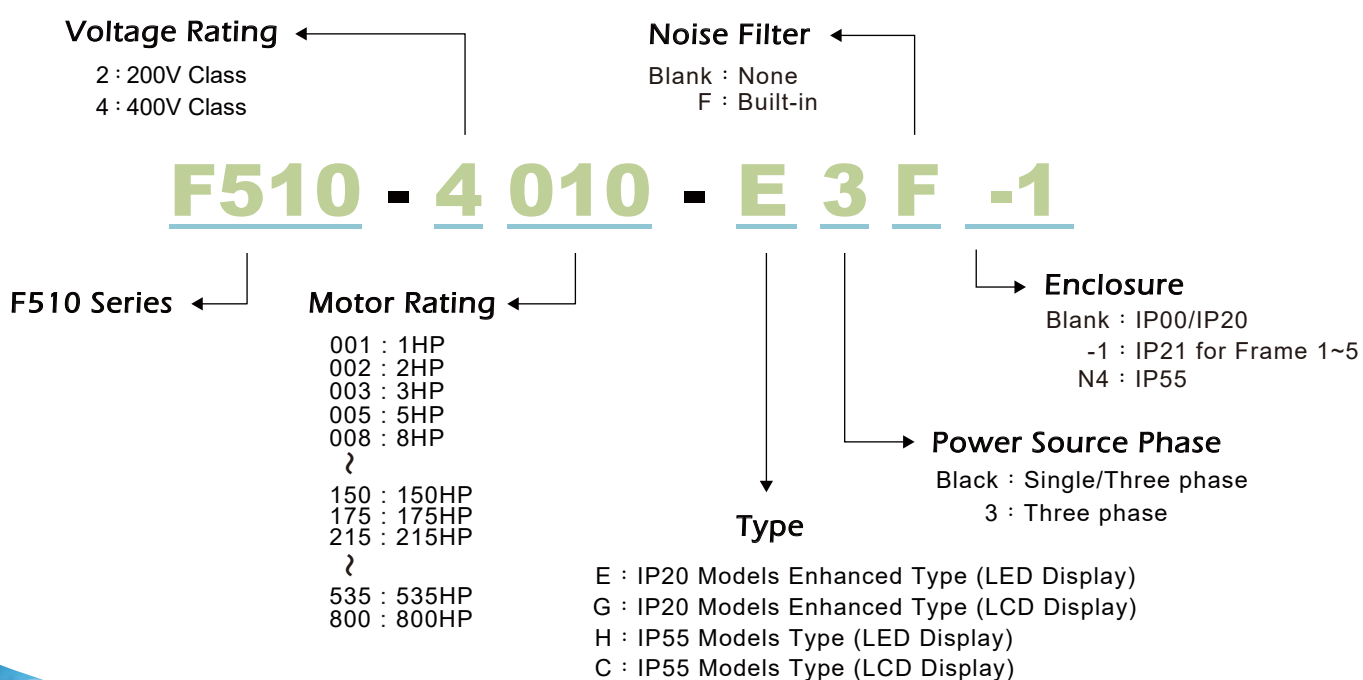

Wiring Diagram (IP20 models)

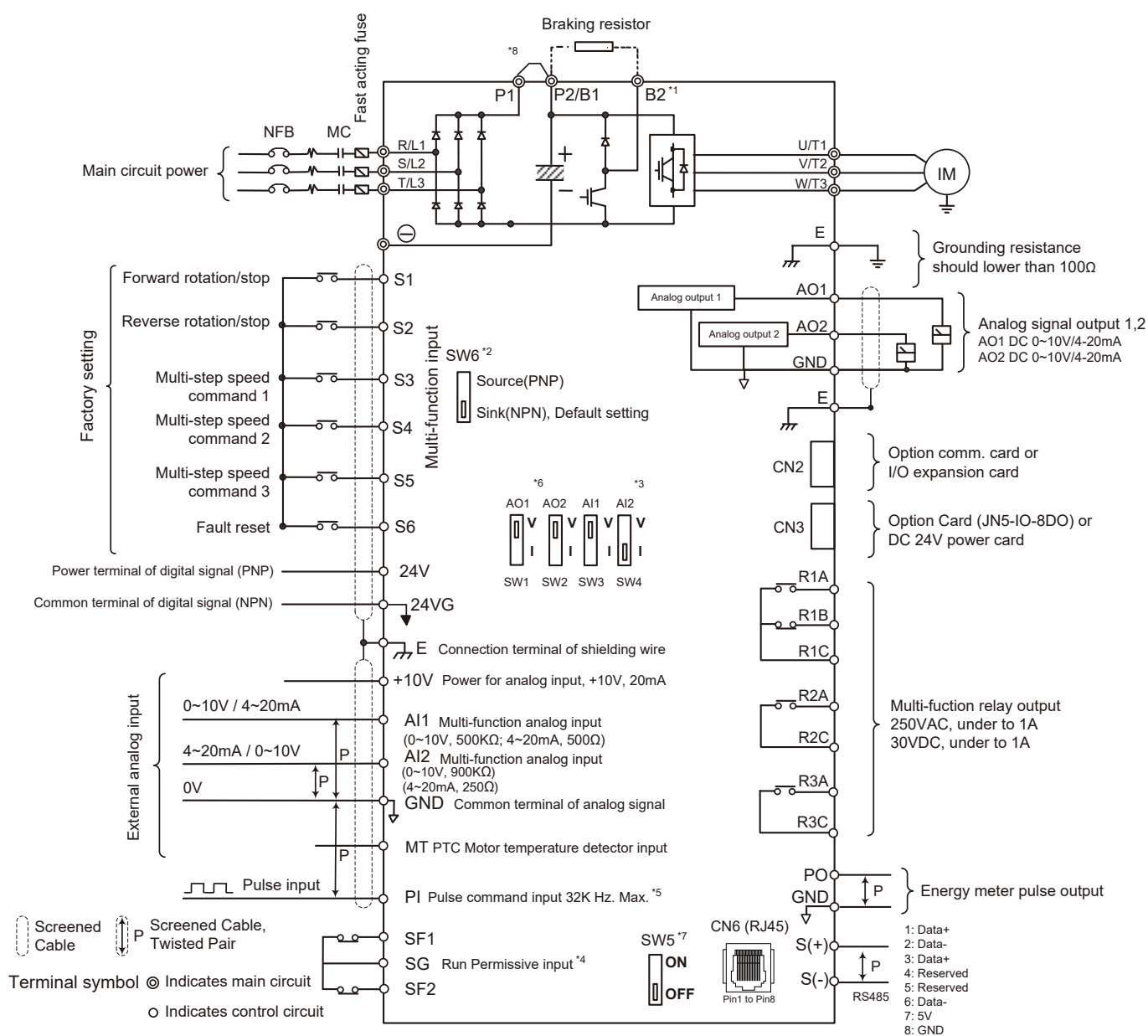

Notes :

- *1: Models IP20 200V 1~30HP, 400V 1~40HP have a built-in braking transistor so that the braking resistor can be connected between terminal B1 and B2.
- *2: The multi-function digital input terminals S1~S6 can be set to Source (PNP) or Sink (NPN) mode via SW6.
- *3: Use SW3/SW4 to switch between voltage (0~10V) and current (4~20mA) input for Multi-function analog input 2 (AI2). Besides please also check parameter 04-00 for proper setting.
- *4: Run permissive input SF1 & SF2 is a normally closed input. This input should be closed to enable the inverter output. To activate this input, open the link between SF1/ SF2 and SG.
- *5: When using the open collector for pulse input, it doesn't need resistance because of built-in pull-up resistance.
- *6: AO1 / AO2 default setting is 0~+10V.
- *7: It need turn on the switch for the terminal resistor RS485 in the last inverter when many inverters in parallel connection.
- *8: Only the models IP20 200V 5~50HP and 400V 5~100HP provide P1 terminal, for external DCL connected between P1 and P2. P1 and P2 are short-circuited before shipping out from the factory.
- *9: Both 200V class 60HP~175HP and 400V class 125HP~425HP have built-in DC reactors.

Wiring Diagram (IP55 models)

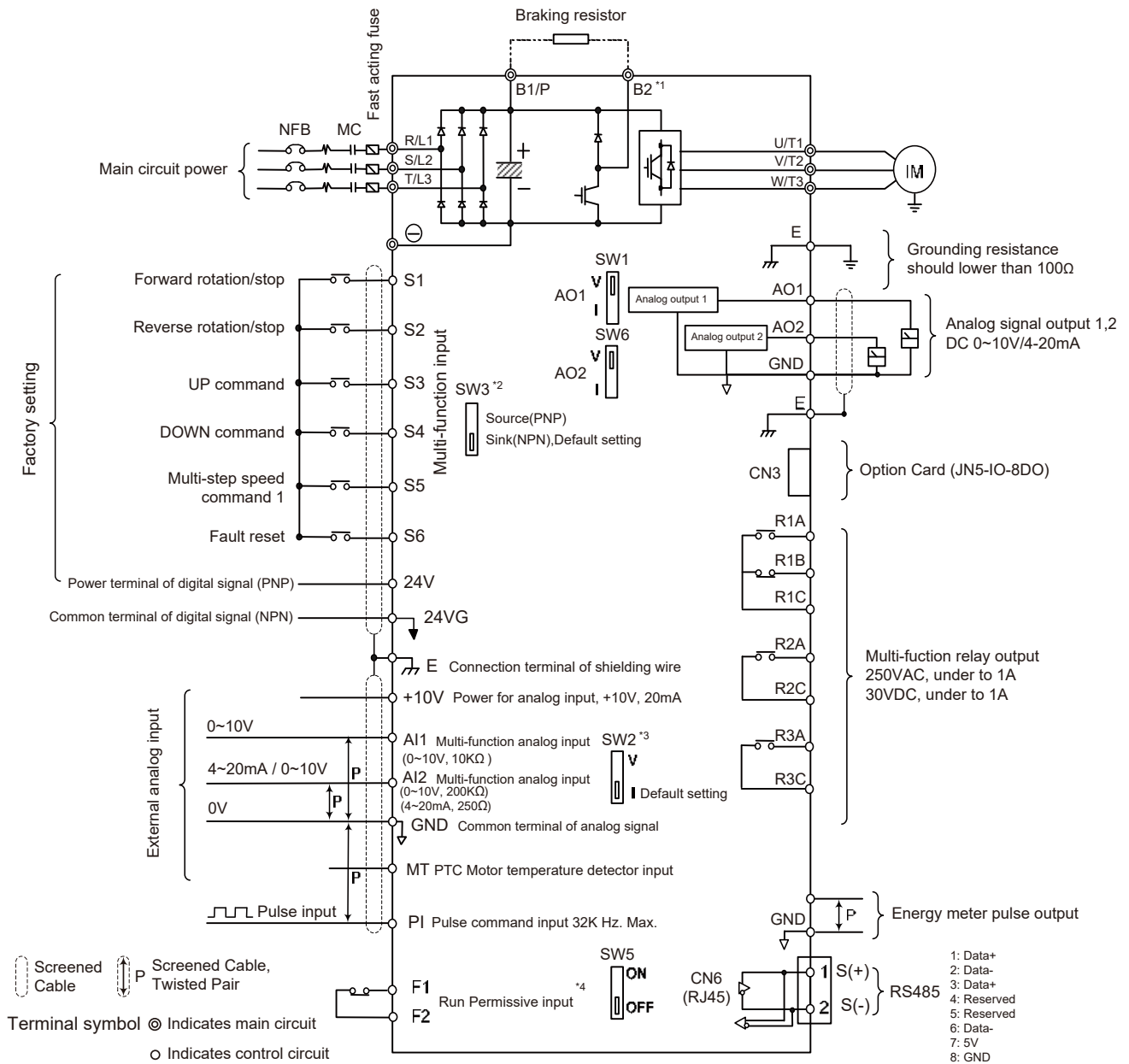

Notes :

- *1: Models IP20 200V 1~30HP, 400V 1~40HP and IP55 400V 1~25HP have a built-in braking transistor so that the braking resistor can be connected between terminal B1 and B2.
- *2: The multi-function digital input terminals S1~S6 can be set to Source (PNP) or Sink (NPN) mode via SW3.
- *3: Use SW2 to switch between voltage (0~10V) and current (4~20mA) input for Multi-function analog input 2 (A12). Besides please also check parameter 04-00 for proper setting.
- *4: Run permissive input F1 & F2 is a normally closed input. This input should be closed to enable the inverter output. To activate this input, open the link between F1 and F2.
- *5: IP20 Frame 6~8 models and all IP55 models are equipped with built-in DC reactors.
- *6: IP20 1~3HP don't support option card.

General Specifications

Control Characteristics	Display	LED keypad with 5-digits seven-segment display or LCD keypad (HOA LCD keypad option)all LCD keypad with parameter copy function
	Control Modes	V/F, SLV, PMSLV with Space Vector PWM Mode
	Output Frequency	0.01Hz ~ 599.0Hz
	Frequency Accuracy	Digital references : $\pm 0.01\%$ (-10 ~ +40°C), Analog references : $\pm 0.1\%$ (25°C $\pm 10^\circ\text{C}$)
	Speed Control Accuracy	$\pm 0.5\%$ (Sensorless Vector Control Mode) *1
	Frequency Setting Resolution	Digital references : 0.01Hz, Analog references : 0.06Hz/60Hz
	Output Frequency Resolution	0.01Hz
	Overload Tolerance	120% / 1 min
	Frequency Setting Signal	DC 0 ~+10V or 4~20 mA
	Acceleration / Deceleration Time	0.0 ~ 6000.0 second (separately set acceleration and deceleration time)
	Voltage / Frequency Characteristics	Can arbitrarily set V / F curve based on parameters
Braking Torque	About 20%	
Main Control Functions	Auto Tuning, Soft-PWM, Over-Voltage Protection, Dynamic Braking, Speed Search, Momentary Power Loss Restart, 2 Sets of PID Control, Slide Difference Compensation, RS-485 Communication Standard, Simple PLC Function, 2 Sets of Analog Output, Safety Switch	
Other Functions	Records of Power On and Operation Time, 4 Fault History Records and Latest Fault Record State, Energy-Saving Function, Phase Loss protection, Smart Braking, DC Braking, Dwell, S Curve Acceleration and Deceleration, Up / Down Operation, Modbus, BACNet MS/TP, and Metasys N2 Communication Protocol, Display of Multi-Engineering Unit, Local / Remote Switch, SINK / SOURCE Input Selection, User Parameter Setting	
Protection Functions	Stall Protection	Current level can be set (in acceleration or constant speed, it can be separately. In deceleration, it can be set with or without protection)
	Over Current (OC) and Output Short-circuit (SC) Protection	It stops when the current exceeds 160% of the inverter rated current
	Inverter Overload Protection (OL2)	Inverter will be stopped when the output higher than 120% rated current for 1 min, Carrier frequency is 2~4 KHZ ²
	Motor Overload Protection (OL1)	Electrical overload protection curve
	Over Voltage Protection (OV)	If the main circuit DC voltage is over 410V (200V class) / 820V (400V class), the motor stops running
	Under Voltage Protection (UV)	If the main circuit DC voltage is under 190V (200V class) / 380V (400V class), the motor stops running
	Momentary Power Loss Restart	Power loss exceeds 15ms. You can set the function of momentary power loss restart up to 2sec
	Overheat Protection(OH)	Thermistor sensor on heatsink
	Ground Fault Protection(GF)	Protection by current detection circuit
	Charge Indicator	When main circuit DC voltage $\geq 50\text{V}$, the CHARGE LED is on
	Input/Output Phase Loss Protection (IPL/OPL)	If the IPL/OPL function acts, the motor stops rotation automatically
Short-circuit Current Rating(SCCR)	Per UL 508C,the drive is suitable for use on a circuit capable of delivering not more than 100KA symmetrical amperes(rms)when protected by fuses given in the fuse table	
Environment Specification	Location	Indoor (protected from corrosive gases and dust)
	Ambient Temperature	-10~+40°C (IP20/IP21), -10~50°C (IP00 or top anti-dust cover removed), with de-rating, the maximum is 60 °C. (Frame 5 is 50°C without de-rating)
	Storage Temperature	-20 ~ +70°C
	Humidity	95%RH or less (no condensation)
	Altitude and Vibration	Altitude of 1000 meters or lower, 1.0G, in compliance with IEC 60068-2-6
	Pollution Degree	Meet IEC 60721-3-3 Class 3C3
Communication Function	Built-in RS-485 as standard (Modbus protocol with RJ45 / BACnet / Metasys N2) (If Metasys N2 protocol will be used, please contact with TECO sales)	
Electromagnetic Interference (EMI)	Meet EN61800-3 Standard, IP20 400V 75HP or below can be built-in	
Electromagnetic Susceptibility (EMS)	Meet EN61800-3 Standard	
Certification	CE	Meet EN61800-3(CE & RE) and EN61800-5-1(LVD)
	UL	UL508C

Notes :

*1: Speed control accuracy will be influenced when the motor and installation condition are different.

*2: The default setting of carrier frequency is different from models.

Dimensions

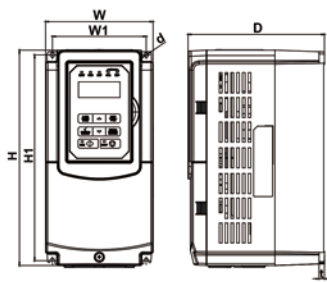

Figure A

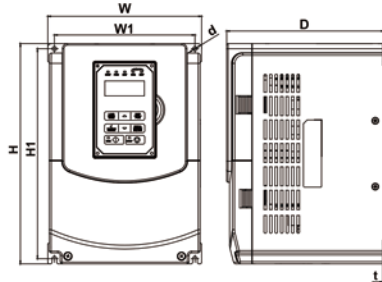

Figure B

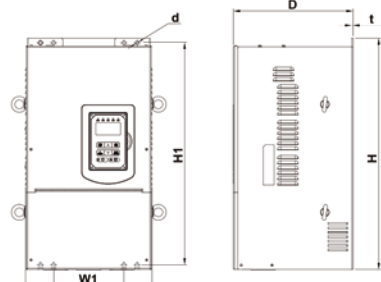

Figure C

Figure	Enclosure	Frame	Catalog No.	Dimensions (mm)							Net Weight (kg)
				W	H	D	W1	H1	t	d	
A	IP20	Frame 1	F510-2001-□	130	215	150	118	203	5	M5	2.2
			F510-2002-□								
			F510-2003-□								
			F510-4001-□3								
			F510-4002-□3								
		F510-4003-□3									
		Frame 2	F510-2005-□3	140	279.5	181	122	267	1.2	M6	3.8
			F510-2008-□3								
			F510-2010-□3								
			F510-4005-□3								
F510-4008-□3											
F510-4010-□3											
B	IP20	Frame 3	F510-2015-□3	210	300	215	192	286	1.6	M6	6.2
			F510-4015-□3								
			F510-4020-□3								
			F510-4025-□3								
		Frame 4	F510-2020-□3	265	360	225	245	340	1.6	M8	10
			F510-2025-□3								
C	IP20	Frame 5	F510-2040-□3	288	526	272	160	505	3.3	M8	27
			F510-2050-□3								
			F510-4050-□3								
			F510-4060-□3								
			F510-4075-□3								
			F510-4100-□3								

Notes :

For 400V Frame 1 ~ Frame 5 models (≤75 HP) with built-in filters, please refer to the user manual for dimensions.

Dimensions

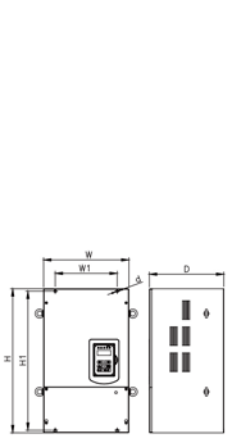

Figure D

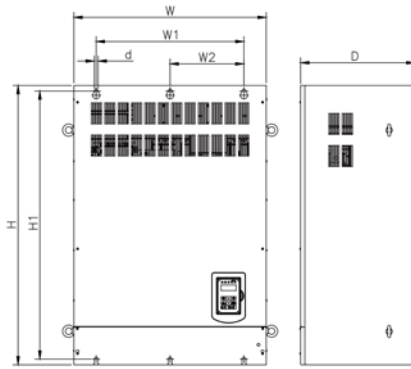

Figure E

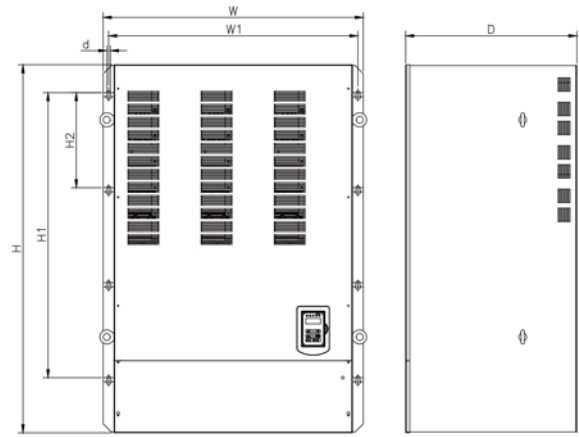

Figure F

Figure	Enclosure	Frame	Catalog No.	Dimensions (mm)									Net Weight (kg)
				W	H	D	W1	W2	H1	H2	t	d	
D	IP00	Frame 6	F510-2060-□3	344	580	300	250	N/A	560	N/A	1.6	M8	40
			F510-2075-□3										
			F510-4125-□3										
			F510-4150-□3										
		Frame 7	F510-2100-□3	459	790	324.5	320	N/A	760	N/A	1.6	M10	74
			F510-2125-□3										
			F510-4175-□3										
			F510-4250-□3										
E	IP00	Frame 8	F510-2150-□3	690	1000	410	530	265	960	N/A	1.6	M12	184
			F510-2175-□3										
			F510-4300-□3										
			F510-4375-□3										
			F510-4425-□3										
F	IP00	Frame 9	F510-4535-□3	958	1356	507	916	N/A	1200	300	6.2	M12	335
			F510-4670-□3										
			F510-4800-□3										

Dimensions

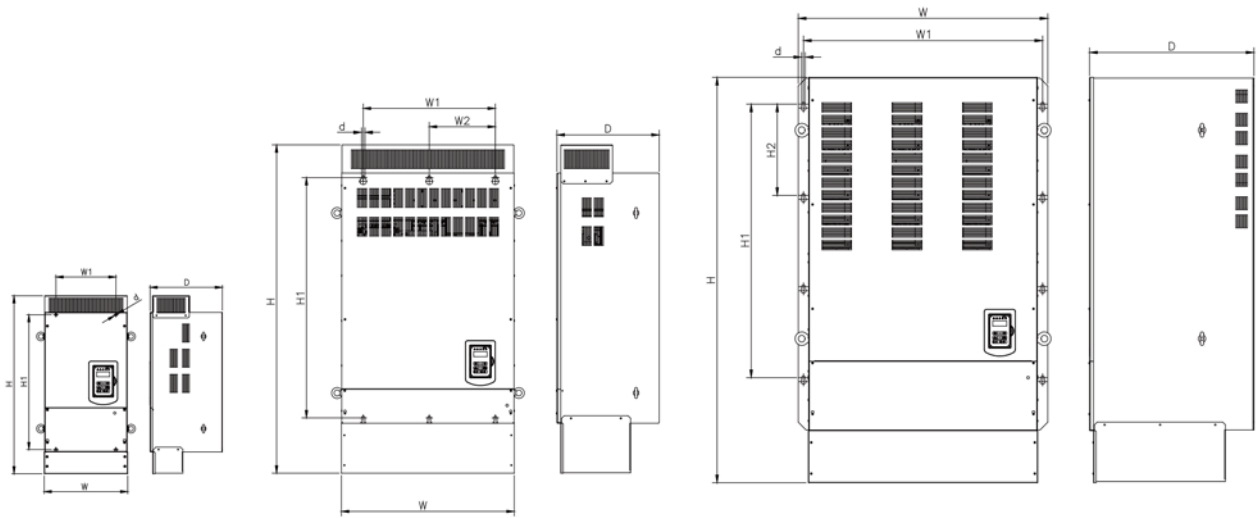

Figure G

Figure H

Figure I

Figure	Enclosure	Frame	Catalog No.	Dimensions (mm)								Net Weight (kg)	
				W	H	D	W1	W2	H1	H2	t		d
G	IP20	Frame 6	F510-2060-□3	348.5	740	300	250	N/A	560	N/A	1.6	M8	44
			F510-2075-□3										
			F510-4125-□3										
			F510-4150-□3										
		Frame 7	F510-2100-□3	463.5	1105	324.5	320	N/A	760	N/A	1.6	M10	81
			F510-2125-□3										
			F510-4175-□3										
H	IP20	Frame 8	F510-4215-□3	692	1313	410	530	265	960	N/A	1.6	M12	194
			F510-4250-□3										
			F510-2150-□3										
			F510-2175-□3										
			F510-4300-□3										
I	IP20	Frame 9	F510-4375-□3	958	1756	507	916	N/A	1200	300	6.2	M12	350
			F510-4425-□3										
			F510-4525-□3										
			F510-4670-□3										
			F510-4800-□3										

*The enclosure type of IP00 model is standard for frame 6 to frame 9. It is required to purchase the installation accessories if user selects the enclosure type of IP20 model.

Frame 6	JN5-NK-A06
Frame 7	JN5-NK-A07
Frame 8	JN5-NK-A08
Frame 9	JN5-NK-A09

Dimensions

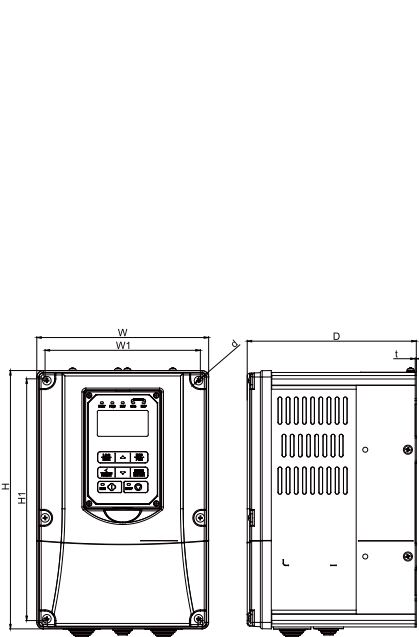

Figure J

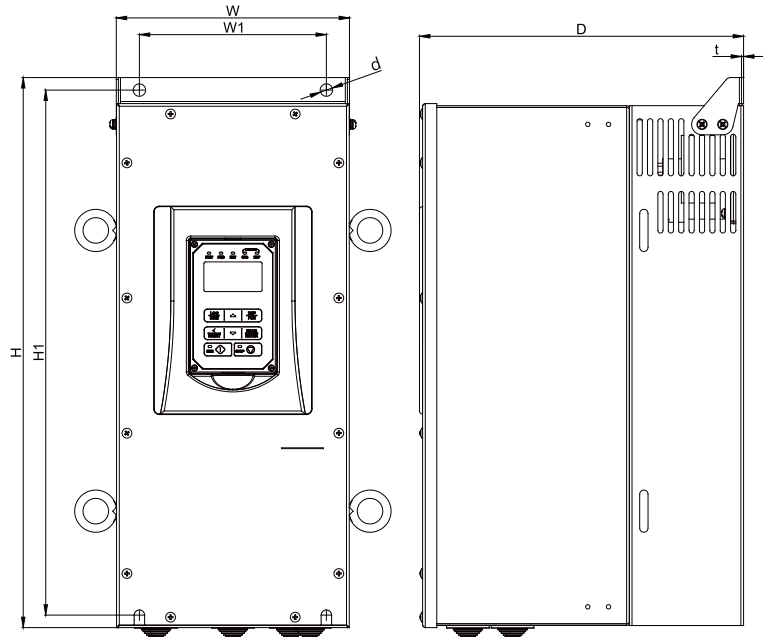

Figure K

Figure	Enclosure	Frame	Catalog No.	Dimensions (mm)						Net Weight (kg)	
				W	H	D	W1	H1	t		d
J	IP55 (NEMA12)	Frame 1	F510-4001-C3FN4	189	284	186	171	266	1.2	M5	5.1
			F510-4002-C3FN4								
			F510-4003-C3FN4								
			F510-4005-C3FN4								
			F510-4008-C3FN4								
Frame 2		F510-4010-C3FN4	230	320	210	210	305	2	M5	8.7	
		F510-4015-C3FN4									
Frame 3		F510-4020-C3FN4	265	396	227	249	380	2	M5	17	
		F510-4025-C3FN4									
K		IP55 (NEMA12)	Frame 4	F510-4030-C3FN4	224	527	311	180	505	2	M10
	F510-4040-C3FN4										
	F510-4050-C3FN4										
	Frame 5		F510-4060-C3FN4	326	695	343	276	671	2.3	M10	55
			F510-4075-C3N4								
				F510-4100-C3N4							

Notes :

No built-in EMC filter on 75~100 HP models

Accessories

Accessories	Description	Catalog No.	Note
Cables	IP20 Digital operator extention cable	JN5-CB-01M	1 meter
		JN5-CB-02M	2 meter
		JN5-CB-03M	3 meter
		JN5-CB-05M	5 meter
	RJ45 to USB connecting cable	JN5-CM-USB	1.8 meter
Communication Gateways	Profibus DP module	JN5-CM-PDP	
	TCP-IP module	JN5-CM-TCPIP	
	DeviceNet module	JN5-CM-DNET	
	CANopen module	JN5-CM-CAN	
	EtherNet/IP module*1	JN5-CM-EIP	
Communication Cards	Profibus DP communication card*1	JN5-CMHI-PDP	
	CANopen communication card*1	JN5-CMHI-CAN	
	EtherCAT communication card*1	JN5-CMHI-ECAT	
	EtherNet/IP communication card*1	JN5-CMHI-EIP	
Bluetooth Keypad*1	For wireless remote connection to control the inverter, which can monitor the real-time status and diagnose faults quickly	JN5-OP-BTH	With the smartphone APP "BT DriveLink", it can be downloaded from Apple APP Store or Google Play
Digital&Analog IO Expansion Card*1	Add one relay output, one transistor, and one -10V~10V / 4~20mA analog input after installation.	JN5-IO-2DO1AI	
DC24V Power Card*1	Use DC24V to communicate with inverter, and setup or copy the parameter without using the main power after installation.	JN5-PS-DC24V	
NEMA1 Kits	Mechanical device consisting of anti-dust cover on the upper part and wiring box on the bottom to meet NEMA1	JN5-NK-A06	For frame 6
		JN5-NK-A07	For frame 7
		JN5-NK-A08	For frame 8
		JN5-NK-A09	For frame 9
Digital Operators	IP20 LED Type	JN5-OP-F01	
	IP20 LCD Type	JN5-OP-F02	
	IP20 LCD HOA Type	JN5-OP-F03	With HAND/OFF/AUTO function
	IP20 Blank Type	JN5-OP-A03	
	IP55 LCD Type	JN5-OP-F04	
Protective Cover	Positioned on both sides of the inverter to prevent unknown objects from invading	JN5-CR-A01	For frame 1
		JN5-CR-A02	For frame 2
		JN5-CR-A04	For frame 4
Middle Layer Case	For 1 to 8 pump cards / communication cards / Digital & Analog I/O Expansion Card / DC24V power card installation (For frame 2– 4 models, if only installing 1 to 8 pump cards, no middle layer case is required) (After installation, the depth will increase)	JN5-MD-A01	For IP20 models Frame 1, D+44mm
		JN5-MD-A02	For IP20 models Frame 2, D+31mm
		JN5-MD-A03	For IP20 models Frame 3, D+34mm
		JN5-MD-A04	For IP20 models Frame 4, D+35mm
Others	1 to 8 Pump card	JN5-IO-8DO	
	Copy Module for 510 series	JN5-CU	

Notes :

*1: Only IP20 models supported.



Distributor



TECO Electric & Machinery Co., Ltd.

10F, No.3-1, Park St., Nan-Kang, Taipei 115, Taiwan
TEL : 886-2-6615-9111 FAX : 886-2-6615-0933 E-mail : ICS@teco.com.tw
www.teco.com.tw

Specifications covered in this brochure may be subject to change without notice.

