



E710

Next-Generation Compact Drive



COMPANY PROFILE

Starting from a major motor manufacturer, TECO has transformed into a business group with high competitiveness and globalized operation, spanning heavy electric equipment, home appliances, information technology, communications, key electronic components and parts, infrastructural engineering, financial investment, dining, and home delivery and other services.



In a global initiative aimed at expanding the business scope and creating a comprehensive marketing and service system, we are developing a new business model and implementing global operations to realize our corporate vision of becoming a world-class brand. We are utilizing innovative technologies and providing excellent services to achieve this goal.



Next-Generation Compact Drive

E710

Miniature, multi-functional, stable and reliable, with more installation space and a stable, safe and reliable production environment.



1 Ultimate

Reduced size
Side by side installation



2 Easy to use

Easy installation
Simple adjustments

Rail mounting
Spring terminals

Buckle design
Copy modules

3 Superior

Multiple drivers
Superior performance

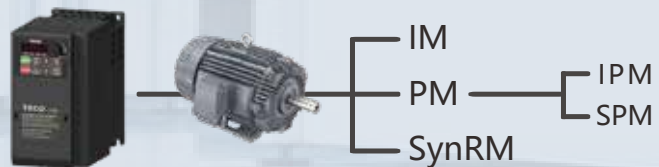

Multi-type PG feedback / Low motor noise / Bluetooth remote connection

4 Stable, safe

Predictive diagnosis
Multiple protection

Advanced process
Demagnetization

Life prediction
Built-in filter

5 Complies with

Global sales
Responsible

UL, cUL, CE
RoHS, REACH

Ultimate space experience

■ Miniaturization

Space saving new technology and dual CPU design



Disk reduction
50%

E710

Ambient temperature -10~50°C without derating

■ Seamless side-by-side installation

Significantly saves installation space, installation costs, and looks clean and attractive



Install side-by-side or add dust-proof stickers: ambient temperature -10~40°C without derating

Motor control algorithm improves quality and quantity

■ One machine with multiple controls, supports IM/PM/SynRM

Induction Motor



Easy installation

Permanent Magnet Motor



- High energy efficiency
- High design density
- Good response
- High starting torque
- Excellent frequency conversion and energy saving

Line-Start Synchronous Reluctance Motor



High energy efficiency

■ Excellent PM motor control

- Innovative vector control
- Algorithm to improve current efficiency
- Demagnetization protection (available December 2023)

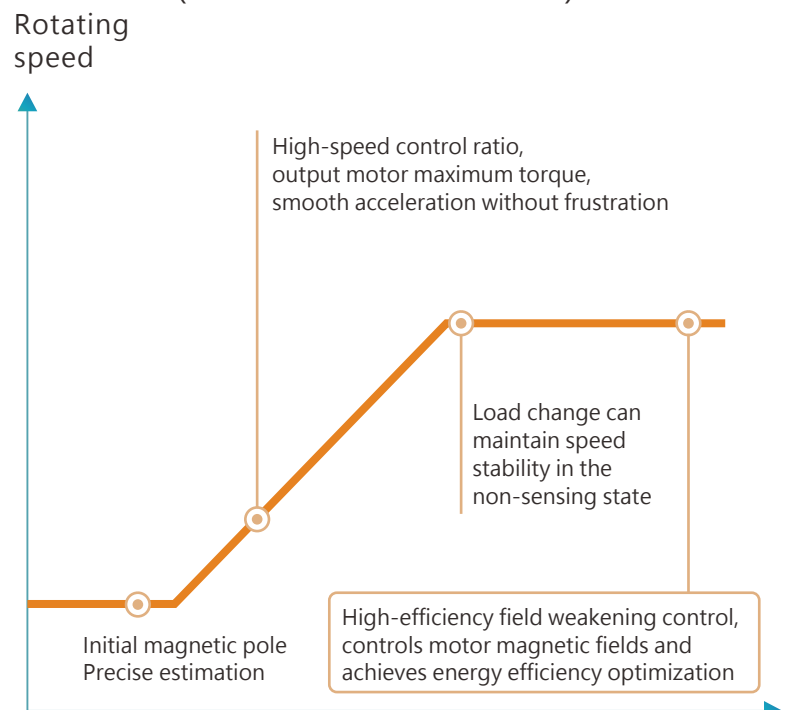

Motor Noise Reduction Technology

- Exclusive Soft PWM control technology reduces the radio frequency interference and motor noise.

Traditional PWM output

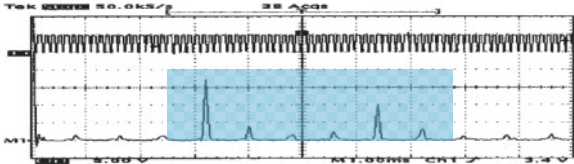

Soft PWM output

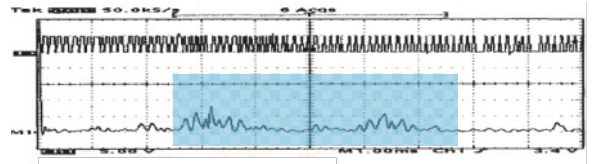

Built-in filter

- Models with built-in EMI filter comply with EN 61800-3 Class I environmental restrictions (C2 level) and reduce electromagnetic interference.

Smart Factory - Smartphone remote connection *Available in December 2023

- The optional LCD bluetooth panel remotely connects inverters with mobile phones so customers can conveniently monitor and adjust machines remotely.
Smart phones can be remotely connected to machines by installing the TECO Bluetooth operator (optional) on the panel to edit parameters and confirm monitoring information in real time.

- Monitor operating conditions
- Parameter setting
- Confirm error records
- Troubleshooting when errors occur



Safety Function

Integrated Safety Torque Off (STO), complies with:

- ◆ EN 60204-1 Category 0
- ◆ EN ISO 13849-1 Cat/PLd
- ◆ EN61508 SIL2
- ◆ EN62061 SIL CL2

Traditional

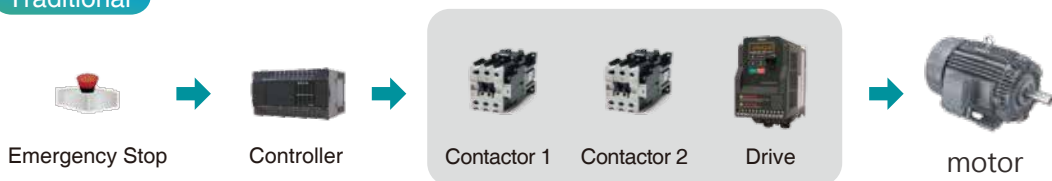

Integrated STO

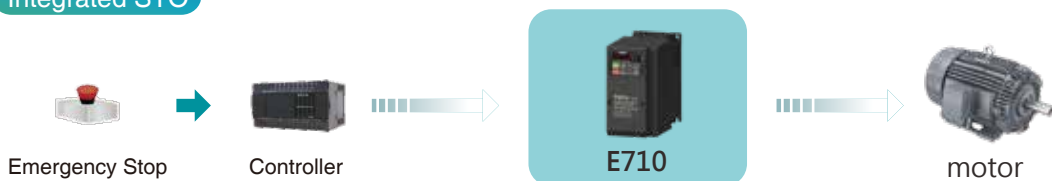

- Protection action is faster
- Saves contactors
- Reduces points of failure

Easy to use

Communication accessories are easy to install, network interfaces and terminals coexist.



- Standard equipped with extendable LED panel
- Compatible with A510s LCD panel



- The fan easily disassembles, convenient for daily cleaning and maintenance.
- The buckle design is convenient for installation.
- Anti-dust stickers for added protection

- Spring-loaded quick-disconnect terminals saves installation time



- Track installation, efficient and convenient



DriveLink humanized compute

Users can use PC software to conveniently and efficiently edit E710 inverter parameters, save, and compare, etc. Improves efficiency of customer parameter settings and on-site debugging.

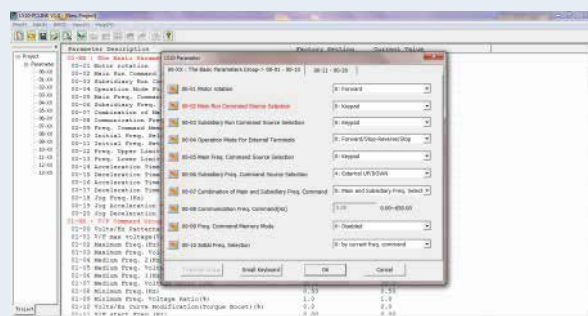

High reliability - automated production

Advanced production processes improve product reliability

- Automated processes improve mass production efficiency and stabilize product quality
- A range of PCB coatings improve product environmental tolerance

Complies with international standards

- Complies with European RoHS/REACH directives
- Complies with international UL/cUL/CE certification



Advanced equipment such as wave soldering furnaces
Lead-free processes



One-stop assembly line
High efficiency and high productivity

Automatic soldering robot arm
ensures solder is error-free



Automatic coating production line
improves product surface wear resistance



Pre-diagnosis of equipment failure

Service life prediction of main parts

Monitors the deterioration status of main part service life (fans, electrolytic capacitors, etc.) and immediately notifies replacement time to ensure continuous and stable operation of the equipment.



Fault warning and diagnosis functions



Inverter life prediction diagnosis



Multiple protection and alarm functions
ensures stable operation of equipment



Running state



Protection of Motor
Real-time monitoring

Motor protection warning function *Available in December 2023

- Prevention of permanent magnet demagnetization (PM motor)
Advanced multi-stage voltage and current stall controls can maximize motor output and prevent PM motor demagnetization to prolong motor life
- Eccentric gap/rotor guide bar, end ring fracture malfunction/stator winding short circuit, open circuit detection (IM motor)

Wiring Diagram (E710 Standard S type) 403~410/202~208

The wiring diagram of the E710 inverter standard model

(⊙ indicates the main circuit terminal / ○ indicates the control circuit terminal).

The position and symbols of the wiring terminal socket of the E710 varies slightly depending on the model.

For descriptions of the main circuit terminals and control circuit terminals, please refer to the following chapters.

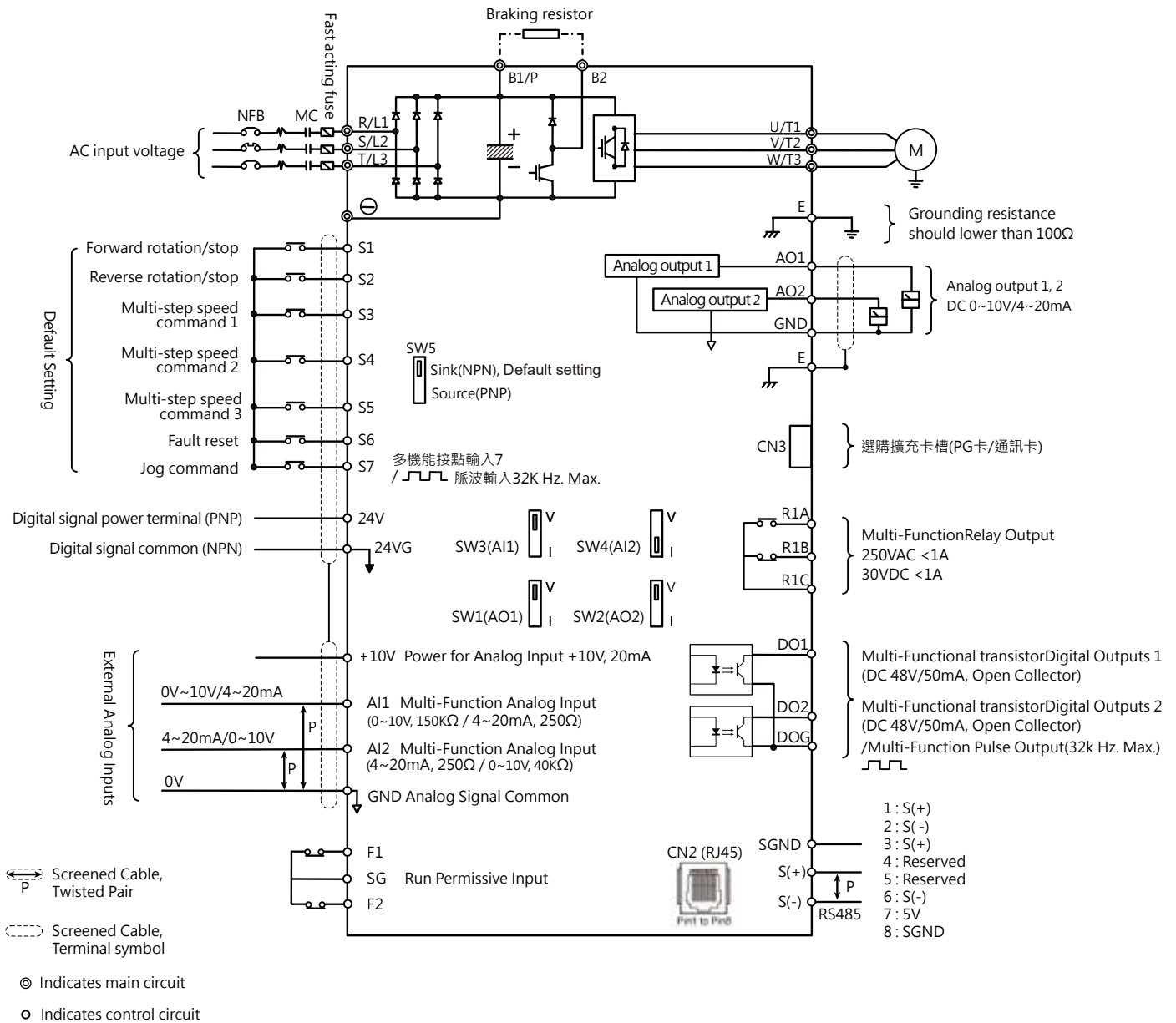

Note

- *1: Use SW5 to select between Sink (NPN, with 24VG common) or Source (PNP, with +24V common) for multi-function digital input terminals S1~S7.
- *2: Use SW3/SW4 to switch between voltage (0~10V) and current (4~20mA) input for Multi-function analog input 1/2 (AI1/AI2). Besides please also check parameter 04-00 for proper setting.
- *3: When S7 is used as pulse input, connecting an external resistor is unnecessary due to the built-in pull-up resistor.
- *4: The safety input contacts F1&F2 are short-circuited to the SG inverter for normal output. When using safety input, remove the short-circuit wires between F1-SG and F2-SG.
- *5: AO1/AO2 presents a 0~10V output can be set to voltage output (0~10V) or current output (4~20mA) through switch SW1/SW2 to match parameter settings.
- *6: When DO2 uses pulse output functions, pull-up resistance is recommended to be 200Ω.

Wiring Diagram (E710 Simple E type) 401 ~ 402/2P5 ~ 201

The wiring diagram of the E710 inverter simple model

(◎ indicates the main circuit terminal / ○ indicates the control circuit terminal).

The position and symbols of the wiring terminal socket of the E710 varies slightly depending on the model.

For descriptions of the main circuit terminals and control circuit terminals, please refer to the following chapters.

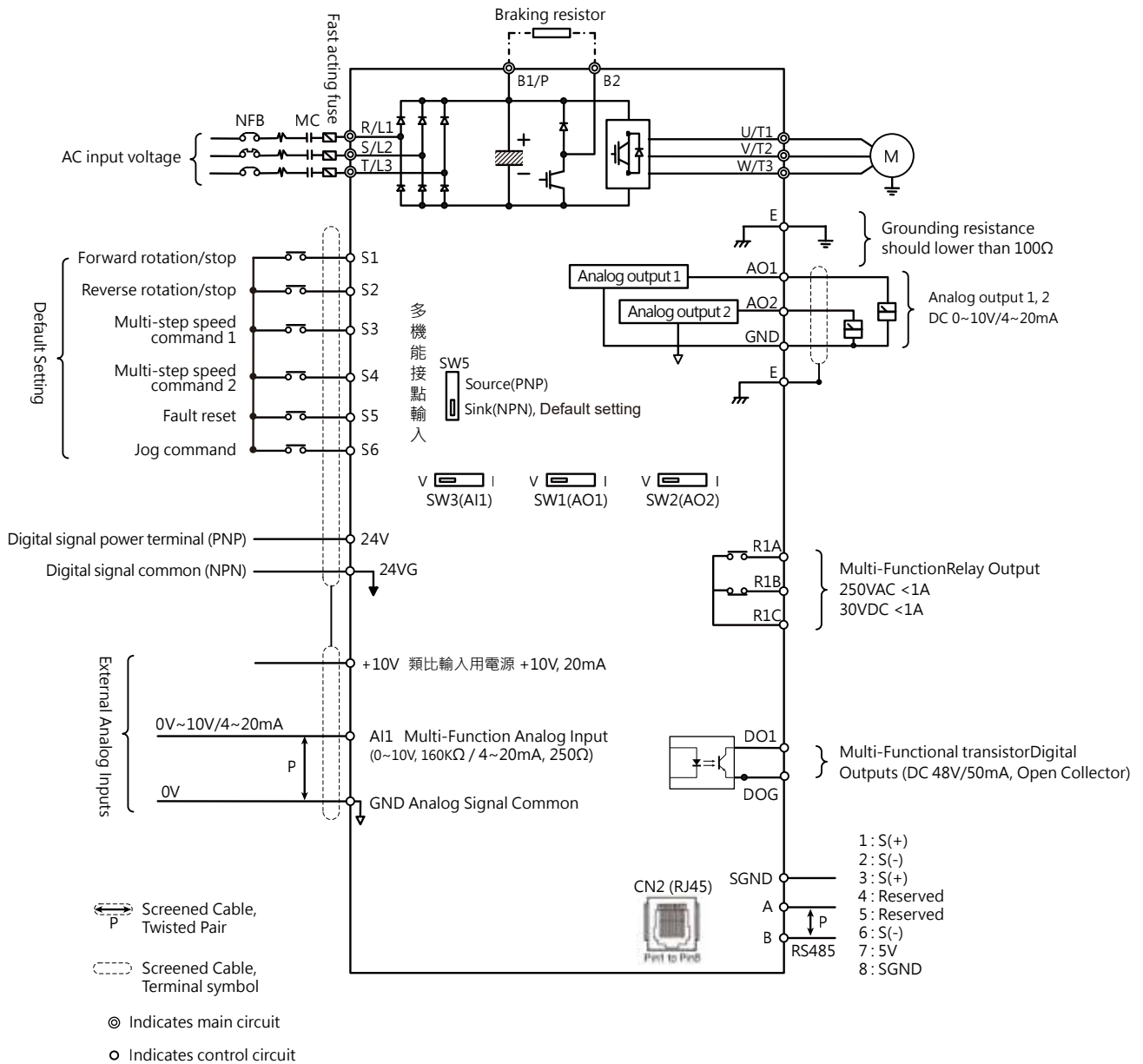

- Note
- *1: Use SW5 to select between Sink (NPN, with 24VG common) or Source (PNP, with +24V common) for multi-function digital input terminals S1~S6.
 - *2: Use SW3 to switch between voltage (0~10V) and current (4~20mA) input for Multi-function analog input 1 (AI1). Besides please also check parameter 04-00 for proper setting.
 - *3: AO1/AO2 presets a 0~10V output can be set to voltage output (0~10V) or current output (4~20mA) through switch SW1/SW2 to match parameter settings.

Catalog Number Identification

E710 - 2 01 - H 1 S F

Input Voltage	Horse Power	Type	Power Supply	E: Simple	Noise Filter
2 : 200V~240V	P5: 0.5HP	Blank : None	Blank :	401~402	Blank : None
4 : 380V~480V	01: 1.0HP	E : LED Display	Single/Three Phase	2P5~201	F : Built-in
	02: 2.0HP		1 : Single-Phase	S: Standard	
	03: 3.0HP		3 : Three-Phase	403~410	
	05: 5.0HP			202~208	
	08: 7.5HP				
	10: 10HP				

General Specifications

Catalog No.	Input Voltage (VAC)	Horse Power	Motor Current	Output Current	Noise Filter		Frame No.
				HD	Built-in	None	
E710-2P5-HE	Single/Three-Phase 200~240V +10% ~ -15% 50/60Hz	0.5	1.68	2.8		⊙	1
E710-201-HE		1	3.25	4.8		⊙	1
E710-202-HS		2	6.16	7.5		⊙	2
E710-203-HS		3	8.23	11		⊙	2
E710-2P5-H1EF	Single-Phase 200~240V +10% ~ -15% 50/60Hz	0.5	0.97	2.8	⊙		1
E710-201-H1EF		1	3.25	4.8	⊙		1
E710-202-H1SF		2	6.16	7.5	⊙		2
E710-203-H1SF		3	8.23	11	⊙		2
E710-205-H3S	Three-Phase 200~240V +10% ~ -15%	5	14.48	17		⊙	2
E710-208-H3S		7.5	19.03	25		⊙	3
E710-401-H3E	Three-Phase 380~480V +10% ~ -15% 50/60Hz	1	1.88	2.7		⊙	1
E710-402-H3E		2	3.56	4.2		⊙	1
E710-403-H3S		3	4.76	5.5		⊙	2
E710-405-H3S		5	8.37	9		⊙	2
E710-408-H3S		7.5	11	13		⊙	3
E710-410-H3S		10	14.8	17		⊙	3
E710-401-H3EF		1	1.88	2.7	⊙		1
E710-402-H3EF		2	3.56	4.2	⊙		1
E710-403-H3SF		3	4.76	5.5	⊙		2
E710-405-H3SF		5	8.37	9	⊙		2
E710-408-H3SF		7.5	11	13	⊙		3
E710-410-H3SF		10	14.8	17	⊙		3

General Specifications

		Standard S type(403~410/202~208)	Simple E type(401~402/2P5~201)
		IM: V/F, V/F+PG, SLV, SV PM: SV, SLV SRM: PMA-SyRM-SLV, SyRM-SLV	IM: V/F, SLV PM: SLV -
Frequency	Frequency control range	0.01~599Hz	
	Starting torque	150%/3Hz(VF) , 150% / 0.5Hz (SLV)	
	Frequency setting resolution	Digital references: 0.01Hz	
		Analog references: 0.06Hz/60Hz	
	Frequency setting	keypad : Set directly with ▲ ▼ keys or the VR on the keypad	
		External Input Terminlas: AI1/AI2 (0~10V / 2~10V / 0~20mA / 4~20mA) input Multifunction input up/down function	
		Setting frequency by communication method.	
Frequency limit	Lower and upper frequency limits 3 skip frequency settings.		
Speed control accuracy	V/F :±2~3%, SLV :± 1%		
Run	Operation set	Keypad run, stop button	
		External terminals: Multi-operation-mode2/3 wire selection, Jog operation	
		Run signal by communication method.	
Main Control Features	V / F curve setting	18 fixed curves and one customized curve	
	Carrier frequency	2~16KHz (default value : 4kHz)	
	Acceleration and deceleration control	2 off Acc / dec time parameters	
		4 off S curve parameters	
	Multifunction input	29 functions (refer to description on group3)	
	Multifunction output	21 functions (refer to description on group3)	
	Multifunction analog output	5 functions (refer to description on group4)	
Main features	Overload Detection,16 preset speeds,Auto-run, Acc/Dec Switch (2 Stages), PID control, Torque boost, Main/Alt run Command select, Main/Alt Frequency Command select, V/F start Frequency, Fault reset		
Display	LED	Display: Parameter / Parameter value / Frequency / Line speed / DC voltage / Output voltage / Output current / PID feedback / input and output terminal status / Heat sink temperature / Program Version / Fault Log.	
	LED Status Indicator	Run / Stop / Forward / Reverse ,and etc	
Protective functions	Overload Protection	The relays to protect the motor and the inverter. (150%/1min)	
	Over voltage	220V: >410V, 380V: >820V	
	Under Voltage	220V: <190V, 380V: <380V	
	Momentary Power Loss Restart	Inverter auto-restart after a momentary power loss.	
	Stall Prevention	Stall prevention for Acceleration/ Deceleration/ Operation.	
	Short-circuit output terminal	Electronic Circuit Protection	
	STO Functions	Standard S type: Output quick break	Simple E type: None
Other protection features	Protection for overheating of heat sink,The carrier frequency decreasing with the temperature function,fault output,reverse prohibit,prohibit for direct start after power up and error recovery , parameter lock up		
Communication control		Standard built-in RS485 communication (Modbus), One to one or One to many control.	
Environment	Operating temperature	Type IP20/NEMA 1 inside switchboard: Without dustproof sticker: -10~50° / With dustproof sticker: -10~40° Side-by-side installation: -10~40°C *De-rating: For usage between 50~60°C, there is a 2% decrease in current for every 1°C increase.	
		Storage temperature	
	Humidity	95% RH or less (no condensation) (Compliance with IEC 60068 - 2-78)	
	Shock	10Hz ≤ f ≤ 57Hz : ±0.075mm Amplitude : 57Hz ≤ f ≤ 150Hz : 1.0G Acceleration: (Compliance with IEC60068-2-6)	
	Protection class	IP20 / NEMA1	
Certification		UL / cUL / CE / RoHS / REACH	

Dimensions

220V : 2P5~201HP/440V : 401~402HP (IP20)

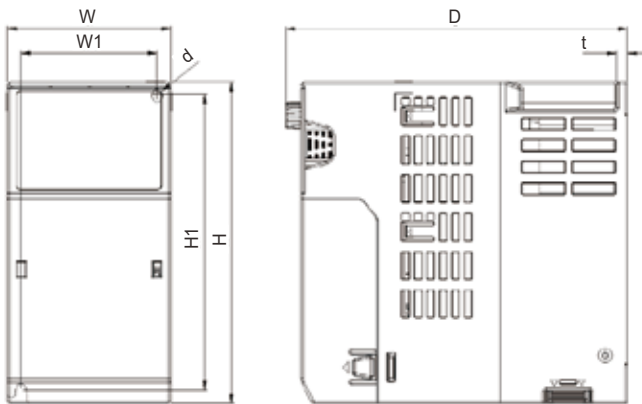

Catalog No.	Dimensions(mm)							Net Weight (kg)
	W	H	D	W1	H1	t	d	
E710-2P5-HE	72	142	150	60	130.5	5	M4	1.2
E710-201-HE	72	142	150	60	130.5	5	M4	1.2
E710-401-H3E	72	142	150	60	130.5	5	M4	1.2
E710-402-H3E	72	142	150	60	130.5	5	M4	1.2

220V : 202~205HP/440V : 403~405HP (IP20)

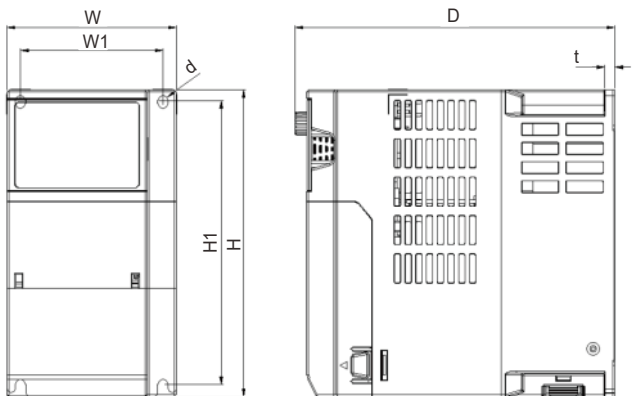

Catalog No.	Dimensions(mm)							Net Weight (kg)
	W	H	D	W1	H1	t	d	
E710-202-HS	87	157	164	73	145	5	M4	1.6
E710-203-HS	87	157	164	73	145	5	M4	1.6
E710-205-H3S	87	157	164	73	145	5	M4	1.6
E710-403-H3S	87	157	164	73	145	5	M4	1.6
E710-405-H3S	87	157	164	73	145	5	M4	1.6

220V : 208HP/440V : 408-410HP (IP20)

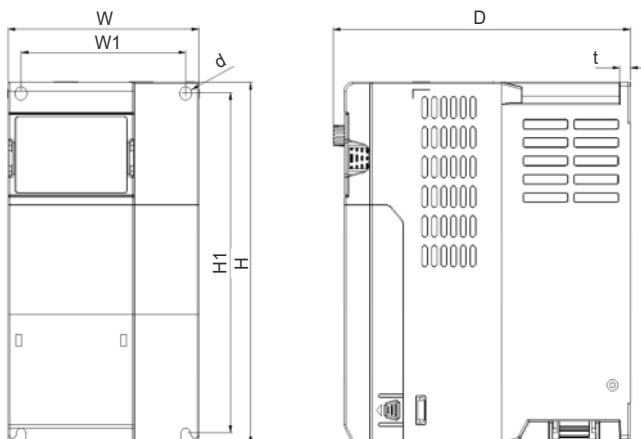

Catalog No.	Dimensions(mm)							Net Weight (kg)
	W	H	D	W1	H1	t	d	
E710-208-H3S	109	207	169	94	194.5	6	M4	2.3
E710-408-H3S	109	207	169	94	194.5	6	M4	2.3
E710-410-H3S	109	207	169	94	194.5	6	M4	2.3

*Please consult local sales personnel regarding filter sizes

E710 industrial applications

- Food machinery
- Packaging and printing
- Fan and water pump
- Woodworking machinery
- Plastic machinery
- Metal processing
- Electronics
- Lithium batteries



Logistics and transportation



Textile machinery



Solar energy

Accessories

Accessories	Catalog No.	Description
510 Series Copy Module	JN5-CU	<p>Copy functions: When the same parameters are to be set for several E710 inverters of the same model, the parameters of one inverter can be preset and the copy module that saves the set parameters can be connected and the parameters can be copied to other machines through the copy module, which can reduce the need to repeat manual settings.</p> <p>Simple panel functions: cannot be used as a panel, please refer to the inverter's instruction manual for specific operations.</p>
Profibus DP Communication Module	JN5-CM-PDP	Development of the JN5-CM-PDP module is for Profibus-dp factory automation applications.
TCP-IP Communication	JN5-CM-TCPIP	For communicating with devices such as inverters/servo drives that support RS485 communication protocols to achieve remote control.
DeviceNet Communication	JN5-CM-DNET	Applicable in automatic control systems using DeviceNet industrial network communication protocols and enables E710 series inverters without DeviceNet functions to run on the DeviceNet network.
CANopen Communication	JN5-CM-CAN	Applicable in automatic control systems adopting CANopen industrial network communication protocols, so that E710 series inverters can run on the CANopen network.
RJ45 to USB Communication cable (1.8m)	JN5-CM-USB	Converts USB communication formats to RS485 communication formats, allowing communication control between the inverter and PC (or other control equipment with USB interfaces), diversifying inverter control.

Accessories

Copy module

JN5-CU



Features

- ▲ It is possible to copy the inverter parameter settings and write them to other inverters.
- ▲ Standard RJ45 network cable

Communication module

Profibus DP、TCP-IP、DeviceNet、CANopen



Features

- ▲ After corresponding products pass through the inverter RS485 interface, the inverter can satisfy the following communication protocols: Profibus DP, TCP-IP, DeviceNet, CANopen

Cable

RJ45 to USB	
JN5-CM-USB	1.8 meters



Features

- ▲ Equipped with TECO computer software's exclusive connection cable. The inverter parameters can be edited through computers.

Built-in option card (coming soon)

- Profibus
- CANopen
- Ethernet / IP
- EtherCAT

**TECO-Westinghouse Motor Company**

Texas 5100 N. IH 35, Round Rock, Texas 78681, USA
Tel: +1-512-255-4141, +1-800-451-8798
Fax: +1-512-244-5512
Toll Free: 1-800-451-8798
Website: www.tecowestinghouse.com
E-mail: sales@tecowestinghouse.com

TECO-Westinghouse Motor Company Inc. (Canada)

18060 - 109th Ave, Edmonton, Alberta T5S 2K2
Tel: +1-780-444-8933
Fax: +1-780-486-4575
24HR Emergency ph: +1(780)994-8964
Toll Free: +1-800-661-4023
Website: www.tecowestinghouse.ca
E-mail: sales@tecowestinghouse.ca

TECO-Westinghouse Motor Company, S.A. de C.V.

Zeta 408, Industrial Delta, Leon, Guanajuato, CP 37545
Tel: +52-472-723-8200
Contact: Victor Iniestra
E-mail: ventas@tecowestinghouse.com

Motovario Ltd.

Rushock Trading Estate, Droitwich,
Worcestershire WR9 0NR,
United Kingdom
Tel: +44 (0)1299 250 859
E-mail for LV: sales@motovario.co.uk
E-mail for MV: enquiries@teco-group.eu
Website: www.motovario.com

Motovario S.P.A.

Via Quattro Passi 1/3 - 41043 Formigine (MO) Italy
Phone: +39 059 579700
Fax: +39 059 579710
E-mail: info@motovario.it
Website: www.motovario.com/eng/

TECO Electric and Machinery GmbH

Industrieweg 21, 30179 Hannover, Germany
Tel: +49 (0) 511 475747 610
Fax: +49 (0) 511 475747 620
E-mail: enquiries@teco-group.eu
Website: www.teco-group.eu

TECO Middle East Electric & Machinery Co., Ltd.

2nd Industrial City, Dammam PO Box #708,
Dammam 31421 Kingdom of Saudi Arabia
Tel: +966-3-812-3939
Fax: +966-3-812-4823
E-mail: sales@teco-me.com

TECO Elektrik Turkey A.S.

Yesilkoy Mah. Atatürk Caddesi No:12 EGS
Business Park, B1 Blok 1. Kat; Daire No: 113 34149,
Bakirkoy/ Istanbul TURKIYE
Tel: +90 212 465 45 90 / +90 507 147 19 69
Website: www.tecoturkey.com
Contact: Peter Hsieh
Email: peterh@teco.com.tw

CREATIVITY DIS. TIC. LTD. STI.

Atakoy 7-8-9-10. Kisim Mah. Selenium Retro 9/A.
D:87 Zip Code: 34158, Bakirkoy/ Istanbul TURKIYE
Tel: +90 212 801 7406
Fax: +90 530 089 7031
Website: http://https://creativityltd.com.tr/
Contact: Teo Aksoy
Email: teo@creativityltd.com.tr

TECO Electric & Machinery Co., Ltd.

New Delhi Office
Tel: +91-11-2231-4654
Contact: Vijay Sankar
Mobile: +91-98733-90999
E-mail: vijay@teco.co.in
kailashkharayat@teco.co.in

PT. TECO Multiguna Elektro

J1. Bandengan Utara No.83/1-3,
Jakarta 14440, Indonesia
Tel: +62-21-6622201
Fax: +62-21-6697029
E-mail: factory@teco.id
marketing@teco.id

Surabaya (East Java) Branch

Jl. Berbek Industri II No. 21 Sidoarjo
(Kawasan Rungkut Industri SBY / SIER)
61256, Jawa Timur, Indonesia
Tel: +62-31-8431952
Fax: +62-31-8436672
E-mail: factory@teco.id
marketing@teco.id

TECO Electronic & Machinery (Thai) Co.,Ltd.

128/1 Soi Watsrivarenoi, Moo 7, Bangna-Trad Rd,
Krn 18, Bangchalong, Bangplee, Samuthprakam 10540
Bangkok,Thailand
Tel: +66-2-337-1311-20
Fax: +66-2-337-1630-1

TECO Technology (Vietnam) Co.,Ltd.

Long Thanh Industrial Zone, Tam An Commune,
Long Thanh District, Dong Nai Province, Vietnam
Tel: +84-9355-73376
Contact: Ms.TRUONG TU GIANG

TECO Electric & Machinery PTE Ltd.

47 Tuas Avenue 9, Singapore 639190
Tel: +65-6265-4622
Fax: +65-6265-7354
Website: www.teco.com.sg

TECO Electric & Machinery SDN. BHD.

-JB Office-
PLO 52 (No.26), Jalan Firma 2/1,
Kawasan Perindustrian Tebrau 1,
81100 Johor Bahru, Johor, Malaysia.
Tel: +60-7-3548008
Fax: +60-7-3546107
E-mail: sales@teco.com.my
-KL Office-
No. 10, Jalan BP 4/4 Bandar Bukit Puchong
47120 Puchong, Selangor.
Tel: +60-3-8062-2299
Fax: +60-3-8060-8869
E-mail: sales-p@teco.com.my

Sankyo Co., Ltd.

29th fl., Hamamatsucho Bldg., 1-1-1,
Shibaura, Minato-ku, Tokyo, Japan, 105-0023
Tel: 81-3-6809-3883
Fax: +81-3-6809-3885
Website: www.teco-japan.com
Contact: Seiho Mabuchi

TECO West Africa, East Africa,

Central Africa and Southern Africa
Email: sales.africa@teco.com.au
Website: http://www.teco.com.au

TECO Australia Pty Limited (Head Office Sydney)

335-337 Woodpark Road, Smithfield NSW 2164
Tel: +61-2-9765-8118
Fax: +61-2-9765-8185
Website: www.teco.com.au
E-mail: sales@teco.com.au

TECO Australia Pty Limited (Melbourne Office)

16 Longstaff Road, Bayswater VIC 3153
Tel: +61-3-9720-4411
Fax: +61-3-9720-5355
Website: www.teco.com.au
E-mail: vicsales@teco.com.au

TECO Australia Pty Limited (Brisbane Office)

50 Murdoch Circuit, Acacia Ridge QLD 4110
Tel: +61-7-3373-9600
Fax: +61-7-3373-9699
Website: www.teco.com.au
E-mail: qldsales@teco.com.au

TECO Australia Pty Limited (Perth Office)

18 Hazelhurst Street, Kewdale WA 6105
Tel: +61-8-9479-4879
Fax: +61-8-9478-3876
E-mail: sales@teco.com.au

TECO New Zealand Ltd.

Unit 3, 477 Great South Road, Penrose, Auckland
Tel: +64-9-526-8480
Fax: +64-9-526-8484
Website: www.teco.com.au
E-mail: sales@teco.co.nz

TECO Electric & Machinery Co., Ltd.(China)

Room 321, Building NO.6,
Lane 1279 Zhongshan W.Rd, Shanghai,
Post 200051, PRC
Tel: +86-21-5116-8255
Fax: +86-21-3209-8761
Website: www.tecochina.net
E-mail: tecosh@teco-china.com.cn

Taian (Subic) Electric, Inc.

Phase 1 Argonaut Highway cor. Braveheart St.
Subic Bay Gateway Park, Subic Bay Freeport Zone -2222-
Zambales, Philippines
Tel: +63-47-252-1324 / +63-47-252-1668
Fax: +63-47-252-3234
Website: www.taiansubic.com
Contact: Roger De Galicia
Email: sb.rdg Galicia@taiansubic.com
Mobile: +63-922-818-0195



For more information,
please visit TECO website.

(EN)E710_20231215