

INSTRUCTION MANUAL

TECO INVERTER



TECO INVERTER

L510s Series

L510s manual

Table of Contents

Chapter 0	Preface	0-1
	0.1 Preface.....	0-1
Chapter 1	Safety Precautions	1-1
	1.1 Before Power UP.....	1-1
	1.2 During Power UP.....	1-1
	1.3 Before Operation.....	1-2
	1.4 During Operation.....	1-2
	1.5 Inverter Disposal.....	1-2
	1.6 Guaranteed Liability Exemption	1-3
Chapter 2	Part Number Definition	2-1
	2.1 Model part number.....	2-1
	2.2 Standard Product Specification.....	2-2
Chapter 3	Environment & Installation	3-1
	3.1 Environment.....	3-1
	3.2 Installation.....	3-3
	3.2.1 Installation methods.....	3-3
	3.2.2 Installation space.....	3-6
	3.2.3 De-rating curve.....	3-9
	3.2.4 Capacitor reforming Guide after long storage.....	3-11
	3.3 Wiring guidelines.....	3-12
	3.3.1 Main Considerations.....	3-12
	3.3.2 Power cables.....	3-13
	3.3.3 Control cable selection and wiring.....	3-13
	3.3.4 Wiring and EMC guidelines.....	3-14
	3.3.5 Failure liability.....	3-15
	3.3.6 Considerations for peripheral equipment.....	3-16
	3.3.7 Ground connection.....	3-17
	3.4 Specifications.....	3-18
	3.4.1 Product Specifications.....	3-18
	3.4.2 General Specifications.....	3-20
	3.5 Standard wiring.....	3-22
	3.5.1 Single phase(NPN) input.....	3-22
	3.5.2 Single phase(PNP) input.....	3-23
	3.5.3 Three phase(NPN) input.....	3-24
	3.5.4 Three phase(PNP) input.....	3-25
	3.5.5 NPN/PNP selectable models.....	3-26
	3.5.6 Single / Multi-Pump Dedicated Wiring Diagram (When 14-00=1).....	3-27
	3.6 Terminal Description.....	3-29
	3.6.1 Description of main circuit terminals.....	3-29
	3.6.2 Description of control circuit terminals.....	3-30

	3.7 Outline Dimensions.....	3-32
	3.8 EMC filter Disconnection.....	3-37
Chapter 4	Software Index.....	4-1
	4.1 Keypad Description	4-1
	4.1.1 Operator Panel Functions.....	4-1
	4.1.2 Digital Display Description.....	4-2
	4.1.3 Digital Display Setup.....	4-4
	4.1.4 Example of Keypad Operation	4-6
	4.1.5 Operation Control.....	4-8
	4.2 Programmable Parameter Groups.....	4-9
	4.3 Parameter Function Description.....	4-29
Chapter 5	Troubleshooting and Maintenance.....	5-1
	5.1 Error Display and Corrective Action.....	5-1
	5.1.1 Manual Reset and Auto-Reset.....	5-1
	5.1.2 Keypad Operation Error Instruction.....	5-4
	5.1.3 Special conditions.....	5-5
	5.2 General troubleshooting.....	5-6
	5.3 Troubleshooting of the inverter.....	5-7
	5.3.1 Quick troubleshooting of the inverter.....	5-7
	5.3.2 Troubleshooting for OC, OL error displays.....	5-9
	5.3.3 Troubleshooting for OV, LV error.....	5-10
	5.3.4 The Motor can not run.....	5-11
	5.3.5 Motor Overheating.....	5-12
	5.3.6 Motor runs unbalanced.....	5-13
	5.4 Routine and periodic inspection.....	5-14
	5.5 Maintenance.....	5-15
Chapter 6	Peripheral Components.....	6-1
	6.1 Reactor Specifications.....	6-1
	6.2 Electromagnetic Contactor & No fuse circuit breaker.....	6-1
	6.2.1 EMC External Filter (C2 Level).....	6-1
	6.3 Fuse Specification.....	6-2
	6.4 Fuse Specification(UL Model Recommended).....	6-2
	6.5 Braking Resistor.....	6-3
	6.6 Copy Unit(JN5-CU).....	6-3
	6.7 Communication option.....	6-4
	6.8 RJ45 to USB connecting Cable (1.8m).....	6-4
	6.9 Remote Keypad (JN5-OP-L01)	6-5
	6.10 JN5-CM-EIP Manual.....	6-7
	6.10.1 Preparations before using the instrument.....	6-7
	6.10.2 Installation of a semi-finished product.....	6-7
	6.10.3 Connection steps.....	6-8
	6.10.4 Running.....	6-15
Appendix 1	L510 Parameters Setting List.....	App1-1

Appendix 2	Instructions for UL.....	App2-1
Appendix 3	L510 MODBUS Communication protocol.....	App3-1
Appendix 4	JN5-CM-USB instruction manual.....	App4-1
Appendix 5	510 series accessories manual.....	App5-1
Appendix 6	IE2 document	App6-1

Chapter 0 Preface

0.1 Preface

To extend the performance of the product and ensure personnel safety, please read this manual thoroughly before using the inverter. Should there be any problem in using the product that cannot be solved with the information provided in the manual, contact our technical or sales representative who will be willing to help you.

※Precautions

The inverter is an electrical product. For your safety, there are symbols such as “Danger”, “Caution” in this manual as a reminder to pay attention to safety instructions on handling, installing, operating, and checking the inverter. Be sure to follow the instructions for highest safety.

Danger

Indicates a potential hazard that could cause death or serious personal injury if misused.

Caution

Indicates that the inverter or the mechanical system might be damaged if misused.

Danger

- Risk of electric shock. The DC link capacitors remain charged for five minutes after power has been removed. It is not permissible to open the equipment until 5 minutes after the power has been removed.
- Do not make any connections when the inverter is powered on. Do not check parts and signals on circuit boards during the inverter operation.
- Do not disassemble the inverter or modify any internal wires, circuits, or parts.
- Ensure that the Inverter Ground terminal is connected correctly.

Caution

- Do not perform a voltage test on parts inside the inverter. High voltage can destroy the semiconductor components.
- Do not connect T1, T2, and T3 terminals of the inverter to any AC input power supply.
- CMOS ICs on the inverter’s main board are susceptible to static electricity. Do not touch the main circuit board.

Chapter 1 Safety Precautions

1.1 Before Power Up

Danger

- Make sure the main circuit connections are correct. Single phase L1(L),L3(N), and Three phase L1(L),L2,L3(N); 400V : L1,L2,L3 are power-input terminals and must not be mistaken for T1,T2 and T3. Otherwise, inverter damage can result.

Caution

- The line voltage applied must comply with the inverter's specified input voltage.(See the nameplate)
- To avoid the front cover from disengaging, or other damage do not carry the inverter by its covers. Support the drive by the heat sink when transporting. Improper handling can damage the inverter or injure personnel and should be avoided.
- To avoid the risk of fire, do not install the inverter on a flammable object. Install on nonflammable objects such as metal.
- If several inverters are placed in the same control panel, provide heat removal means to maintain the temperature below 50 degree C to avoid overheat or fire.
- When disconnecting the remote keypad, turn the power off first to avoid any damage to the keypad or the inverter.

Installation limitation, -10~50°C (cooling fan inside model), -10~40°C (without cooling fan inside model)

Warning

- This product is sold subject to EN 61800-3 and EN 61800-5-1.
In a domestic environment this product may cause radio interference in which case the user may be required to apply corrective measures.

Caution

- Work on the device/system by unqualified personnel or failure to comply with warnings can result in severe personal injury or serious damage to material. Only suitably qualified personnel trained in the setup, installation, commissioning and operation of the product should carry out work on the device/system.
- Only permanently-wired input power connections are allowed.

1.2 During Power Up

Danger

- When the momentary power loss is longer than 2 seconds, the inverter will not have sufficient stored power for its control circuit. Therefore, when the power is re-applied, the run operation of the inverter will be based on the setup of following parameters:

- Run parameters. 00-02 or 00-03.
- Direct run on power up. Parameter. 07-04 and the status of external run switch,

Note- the start operation will be regardless of the settings for parameters 07-00/07-01/07-02.

Danger. Direct run on power up.

If direct run on power up is enabled and inverter is set to external run with the run FWD/REV switch closed then the inverter will restart.

Danger

Prior to use, ensure that all risks and safety implications are considered.

- When the momentary power loss ride through is selected and the power loss is short, the

inverter will have sufficient stored power for its control circuits to function, therefore, when the power is resumed the inverter will automatically restart depending on the setup of parameters 07-00 & 07-01.

1.3 Before Operation

Caution

- Make sure the model and inverter capacity are the same as that set in parameter 13-00.

Note : On power up the supply voltage set in parameter 01-01 will flash on display for 2 seconds.

1.4 During Operation

Danger

- Do not connect or disconnect the motor during operation. Otherwise, It may cause the inverter to trip or damage the unit.

Danger

- To avoid electric shock, do not take the front cover off while power is on.
- The motor will restart automatically after stop when auto-restart function is enabled. In this case, care must be taken while working around the drive and associated equipment .
- The operation of the stop switch is different than that of the emergency stop switch. The stop switch has to be activated to be effective. Emergency stop has to be de-activated to become effective.

Caution

- Do not touch heat radiating components such as heat sinks and brake resistors.
- The inverter can drive the motor from low speed to high speed. Verify the allowable speed ranges of the motor and the associated machinery.
- Note the settings related to the braking unit.
- Risk of electric shock. The DC link capacitors remain charged for five minutes after power has been removed. It is not permissible to open the equipment until 5 minutes after the power has been removed.

Caution

- The Inverter should be used in environments with temperature range from (14-104°F) or (-10 to 40°C) and relative humidity of 95%.

Note: models with fan : -10~50°C , models without fan : -10~40°C

Danger

- Make sure that the power is switched off before disassembling or checking any components.

1.5 Inverter Disposal

Caution

Please dispose of this unit with care as an industrial waste and according to your required local regulations.

- The capacitors of inverter main circuit and printed circuit board are considered as hazardous waste and must not be burnt.
- The Plastic enclosure and parts of the inverter such as the cover board will release harmful gases if burnt.



Equipment containing electrical components may not be disposed of together with domestic waste. It must be separately collected with electrical and electronic waste according to local and currently valid legislation.

1.6 Guaranteed Liability Exemption

- Loss of opportunity caused by the company's products, damage to customers of your company or your company, damage to non-company products, or compensation for other businesses, whether within the warranty period or not, is not covered by the company.

Chapter 2 Part Number Definition

2.1 Model Part Number

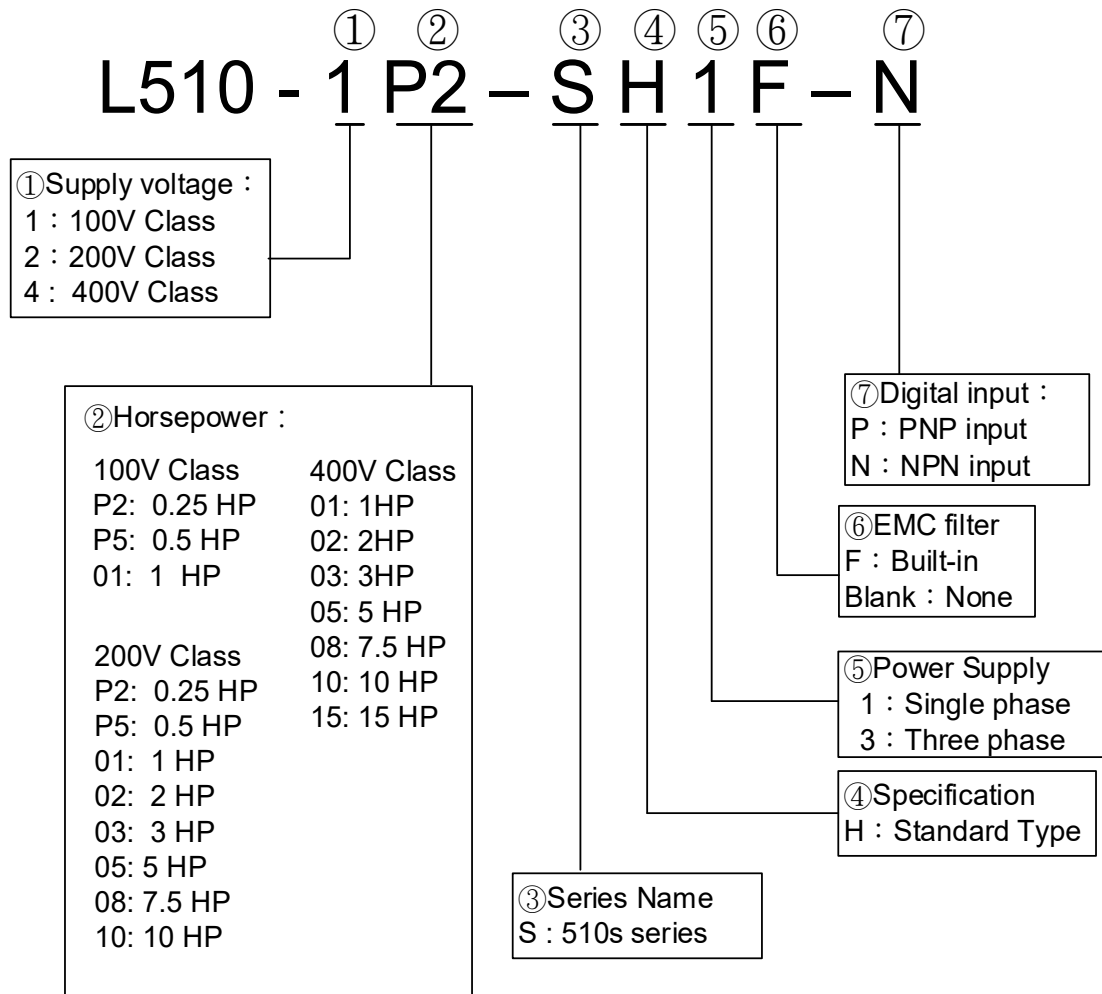

Note :

1. 102/1P5/101/2P2/2P5/201/202/203/401/402/403 models need to select digital input type by code ⑦ (NPN or PNP input).
2. 205/208/210/405/408/410/415 models need to select digital input type by control terminal, please refer the wiring diagram of chapter 3.

2.2 Standard Product Specification

Model	Supply Voltage (Vac)	Frequency (Hz)	(HP)	(KW)	Model		Filter		
					NPN	PNP	Built-in	None	
L510-1P2-SH1-N	1ph, 100~120V +10%/-15%	50/60Hz 50/60Hz 50/60Hz	0.25	0.2	⊙			⊙	
L510-1P5-SH1-N			0.5	0.4	⊙			⊙	
L510-101-SH1-N			1	0.75	⊙			⊙	
L510-2P2-SH1F-P	1ph, 200~240V +10%/-15%		0.25	0.2		⊙	⊙		
L510-2P5-SH1F-P			0.5	0.4		⊙	⊙		
L510-201-SH1F-P			1	0.75		⊙	⊙		
L510-202-SH1F-P			2	1.5		⊙	⊙		
L510-203-SH1F-P			3	2.2		⊙	⊙		
L510-2P2-SH1-N			0.25	0.2	⊙			⊙	
L510-2P5-SH1-N			0.5	0.4	⊙			⊙	
L510-201-SH1-N			1	0.75	⊙			⊙	
L510-202-SH1-N			2	1.5	⊙			⊙	
L510-203-SH1-N			3	2.2	⊙			⊙	
L510-2P2-SH3-N			3ph, 200~240V +10%/-15%	0.25	0.2	⊙			⊙
L510-2P5-SH3-N				0.5	0.4	⊙			⊙
L510-201-SH3-N	1			0.75	⊙			⊙	
L510-202-SH3-N	2			1.5	⊙			⊙	
L510-203-SH3-N	3			2.2	⊙			⊙	
L510-205-SH3	5			3.7	⊙	⊙		⊙	
L510-208-SH3	8			5.5	⊙	⊙		⊙	
L510-210-SH3	10			7.5	⊙	⊙		⊙	
L510-401-SH3-N	3ph, 380~480V +10%/-15%			1	0.75	⊙			⊙
L510-402-SH3-N				2	1.5	⊙			⊙
L510-403-SH3-N			3	2.2	⊙			⊙	
L510-401-SH3F-P			1	0.75		⊙	⊙		
L510-402-SH3F-P			2	1.5		⊙	⊙		
L510-403-SH3F-P			3	2.2		⊙	⊙		
L510-405-SH3			5	3.7	⊙	⊙		⊙	
L510-408-SH3			8	5.5	⊙	⊙		⊙	
L510-410-SH3			10	7.5	⊙	⊙		⊙	
L510-415-SH3		15	11	⊙	⊙		⊙		
L510-405-SH3F		05	3.7	⊙	⊙	⊙			
L510-408-SH3F		08	5.5	⊙	⊙	⊙			
L510-410-SH3F		10	7.5	⊙	⊙	⊙			
L510-415-SH3F		15	11	⊙	⊙	⊙			

Short circuit capacity is below 5000A/120V or 5000A/240V or 5000A/480V, for 100~120V models is 120V; 200~240V models is 240V, 380~480V models is 480V.

Chapter 3 Environment & Installation

3.1 Environment

Installation environment has a direct effect on the correct operation and the life expectancy of the inverter, Install the inverter in an environment complying with the following conditions:

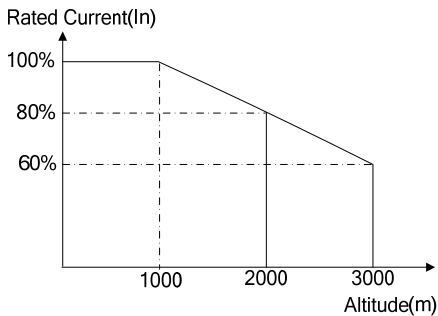
Protection											
Protection class	IP20 Open Type										
Suitable environment											
Operating temperature	-10~40°C (-10~50°C with fan) (non-freezing) If several inverters are installed in the same control panel, ensure adequate spacing and provide the necessary cooling and ventilation for successful operation.										
Storage temperature	-20~60°C										
Relative Humidity	95% RH below (without condensation)										
Altitude	<p>Altitude : Below 1000m (3281ft)</p> <p>It is required to reduce 2% of inverter rated current at each additional 100m. The maximum altitude is 3000m</p>  <table border="1"> <caption>Altitude vs Rated Current Data</caption> <thead> <tr> <th>Altitude (m)</th> <th>Rated Current (In)</th> </tr> </thead> <tbody> <tr> <td>0</td> <td>100%</td> </tr> <tr> <td>1000</td> <td>100%</td> </tr> <tr> <td>2000</td> <td>80%</td> </tr> <tr> <td>3000</td> <td>60%</td> </tr> </tbody> </table>	Altitude (m)	Rated Current (In)	0	100%	1000	100%	2000	80%	3000	60%
Altitude (m)	Rated Current (In)										
0	100%										
1000	100%										
2000	80%										
3000	60%										
Vibration	<p>Frequency: 10Hz - 150Hz - 10Hz</p> <p>Amplitude(0.3mm): 10Hz ≤ f ≤ 57Hz</p> <p>Acceleration(2G): 57Hz ≤ f ≤ 150Hz</p> <p>(According to IEC60068-2-6 standard)</p>										

Installation site

Install in an environment that will not have an adverse effect on the operation of the unit and ensure that there is no exposure to areas such as that listed below:-

- Direct sunlight, Rain or moisture
- Oil mist and salt
- Dust, lint fibres, small metal filings and corrosive liquid and gas
- Electromagnetic interference from sources such as welding equipment
- Radioactive and flammable materials
- Excessive vibration from machines such as stamping, punching machines
- Add vibration-proof pads if necessary

Product Overview

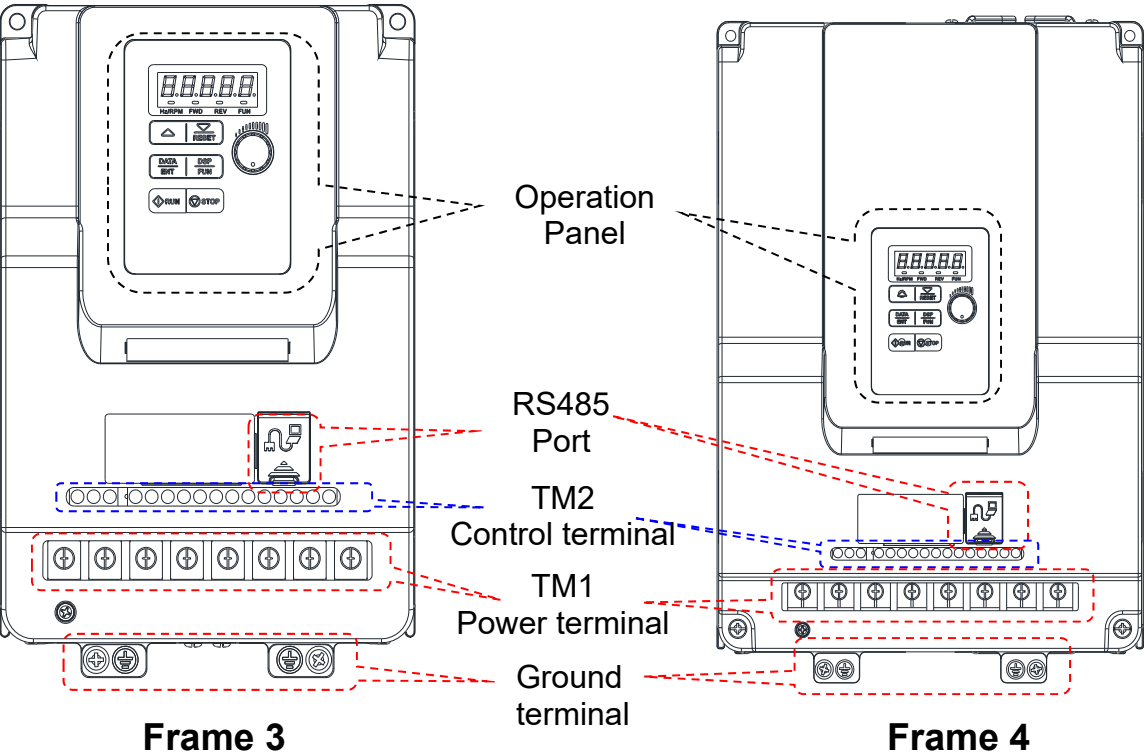
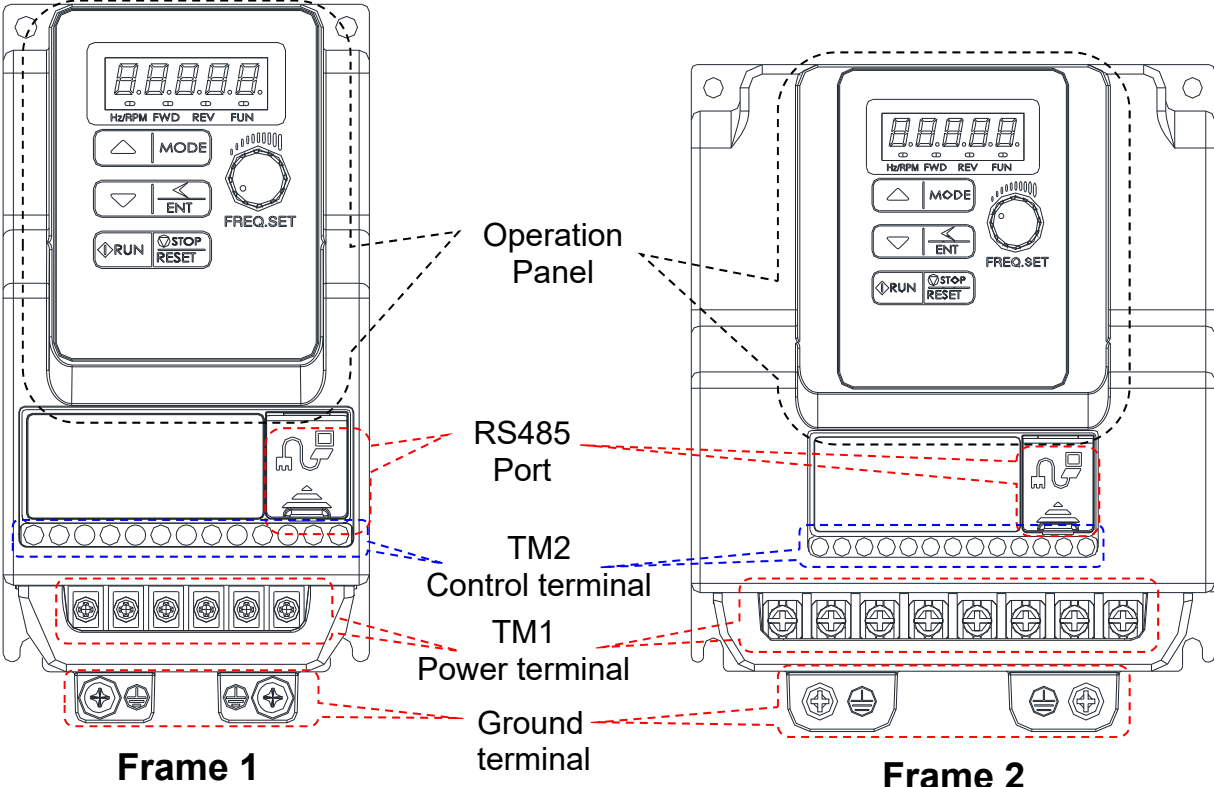

3.2 Installation

3.2.1 Installation methods

Frame1. Mounting on a flat surface.

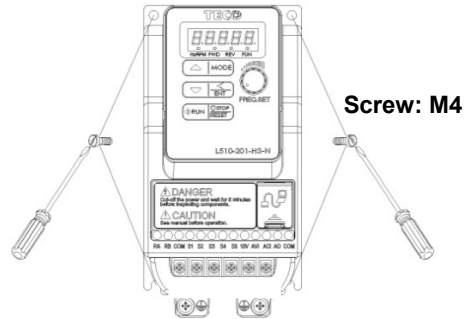

Din rail type installation:

Din rail kit includes a plastic and a metal adaptor plates.

Assembly Steps:-

- 1) Attach the metal adaptor plate to the inverter base with the screws provided.
- 2) Attach the plastic Din rail adaptor to the metal adaptor plate.
- 3) Push the plastic adaptor forward to lock into position.

Disassembly Steps:-

- 1) Unlock by pushing the snap hooks
- 2) Retract and remove the plastic Din rail adaptor.
- 3) Unscrew the metal plate & Remove

Assembly:-

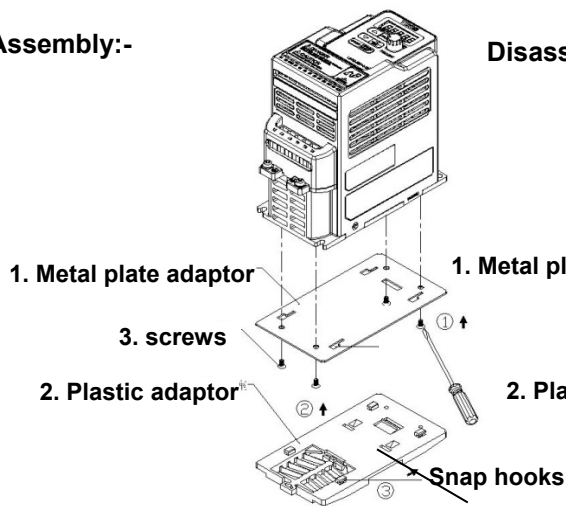

Disassembly:-

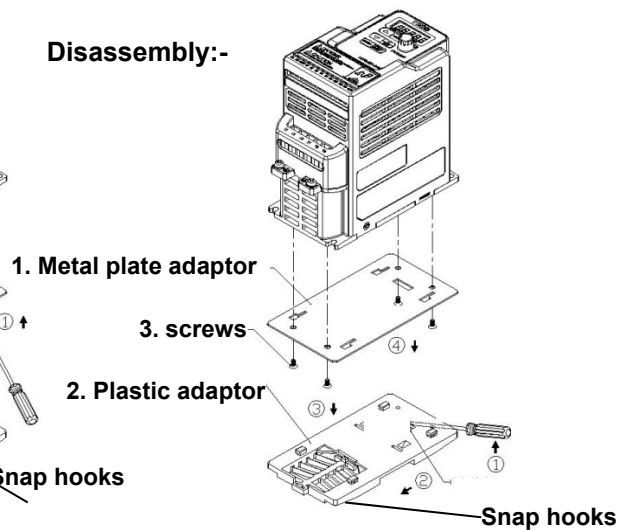

Note:

JN5-DIN-L01 (Frame 1 Din-rail kit part number), including the following parts

1. Metal plate adaptor
2. Plastic adaptor
3. Chamfer head screw: M3×6

Frame 2. Mounting on a flat surface.

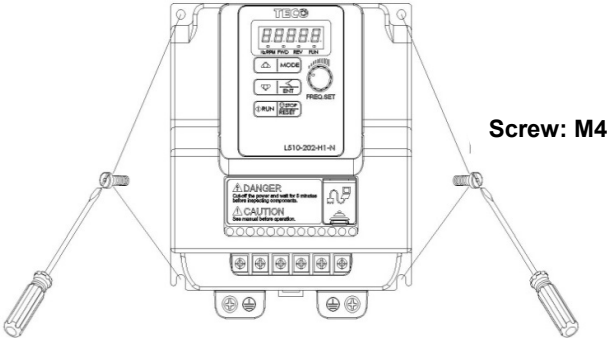

Din rail type installation:

Din rail kit includes a plastic adaptor plate as an attachment for the inverter base. Refer to Diagram below:-

Assembly:-

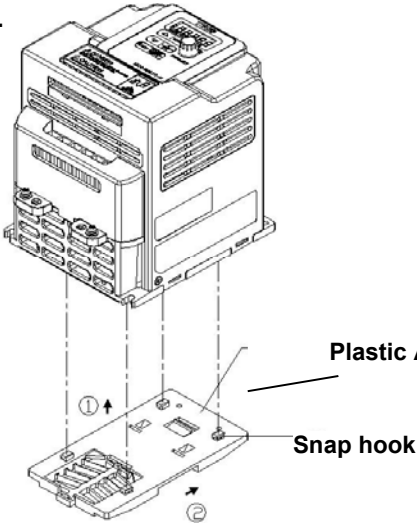

Disassembly:-

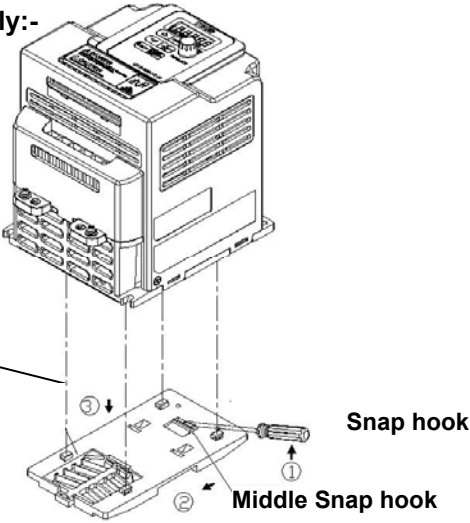

Din Rail Mounting & Dismounting as shown in the diagram below:-Use a 35mm Din Rail.

Mounting

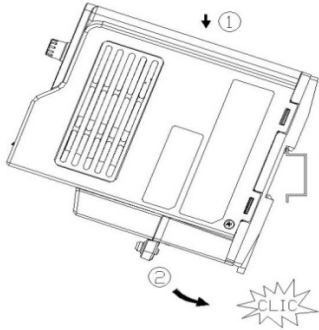

Dismounting

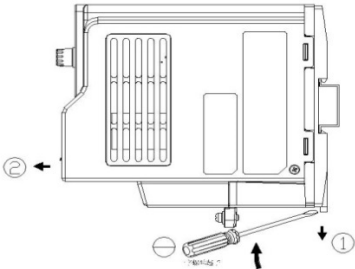

Plastic adaptor plate.
JN5-DIN-L02 (Frame 2 Din rail kit part number)

Frame 3. Mounting on a flat surface

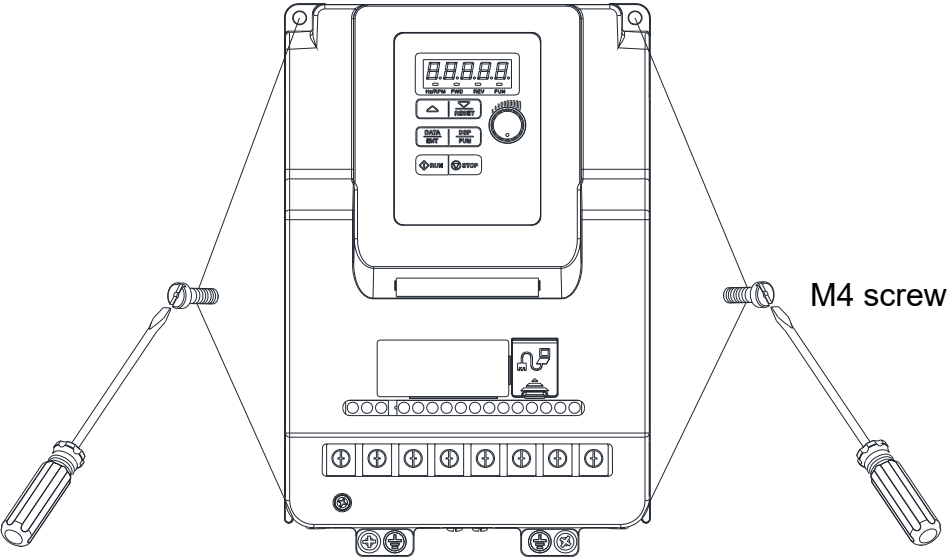

Frame 4. Mounting on a flat surface

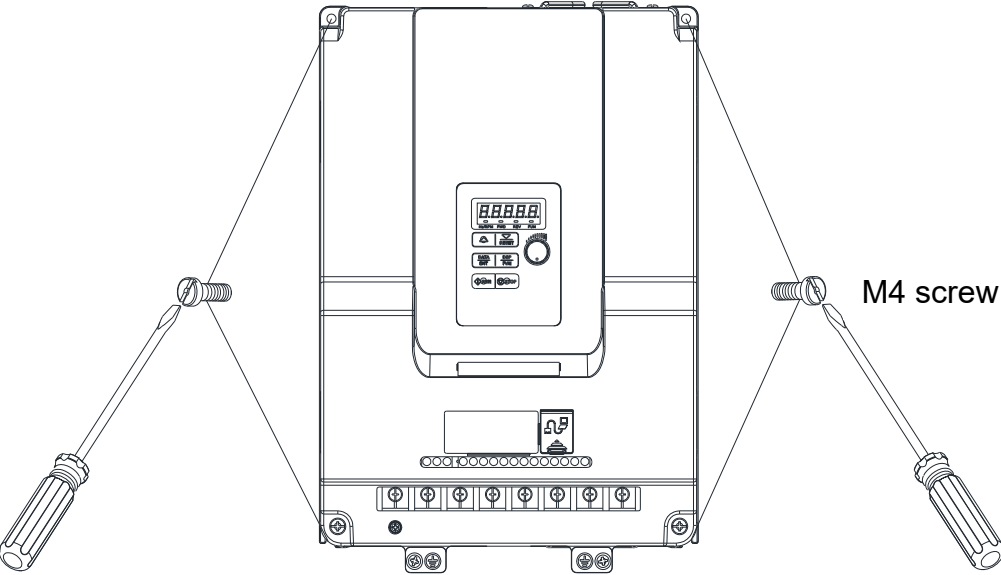

3.2.2 Installation space

Provide sufficient air circulation space for cooling as shown in examples below. Install the Inverter on surfaces that provide good heat dissipation.

Single unit Installation

Install the inverter vertically to obtain effective cooling.

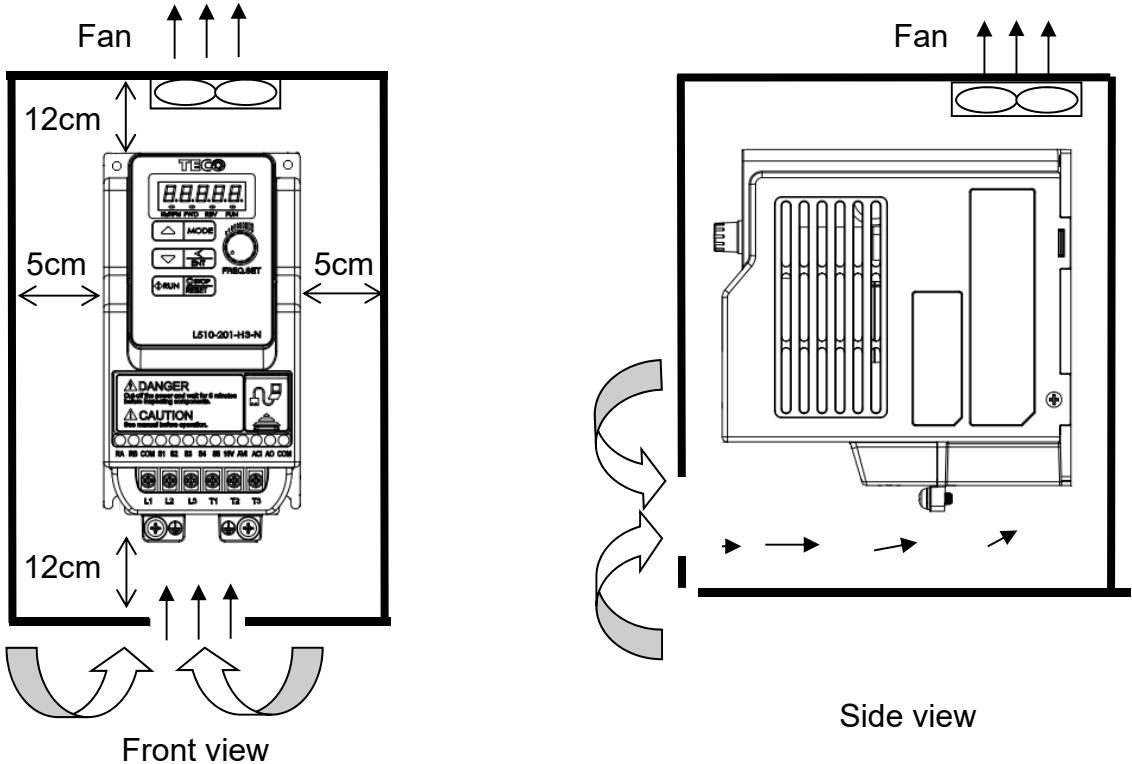

Side by side Installation

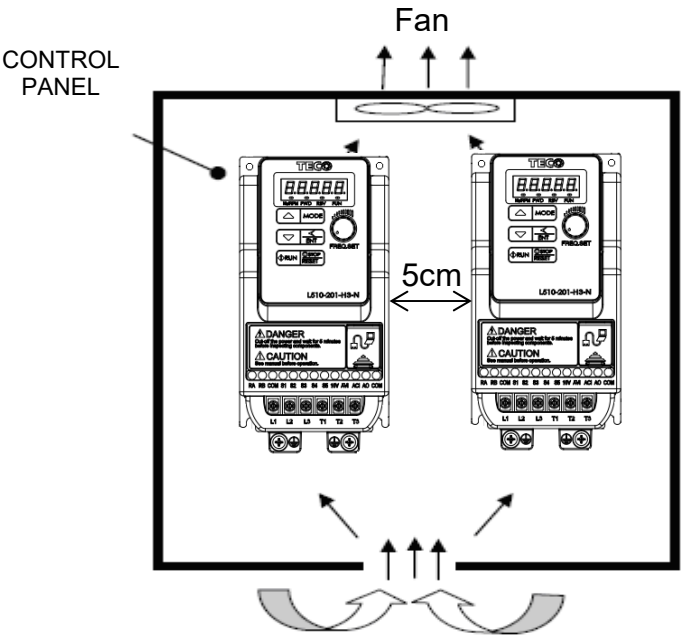

Provide the necessary physical space and cooling based on the ambient temperature and the heat loss in the panel

Installation for Grounding kit

Grounding kit :

As bellowed diagram, use screw to install EMC metal plate into heatsink.

Frame 1

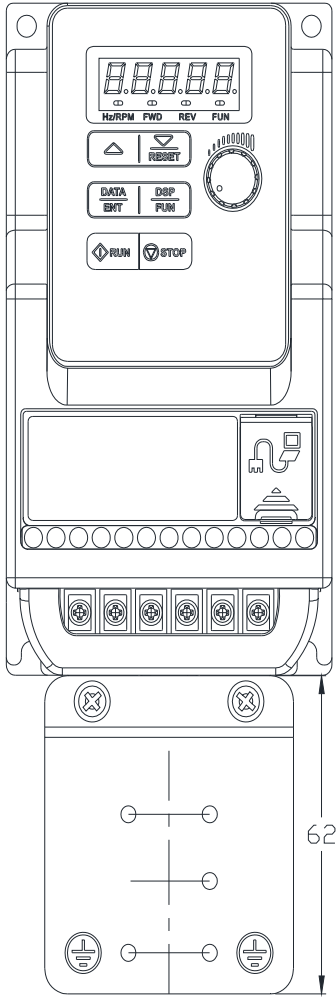

Frame 2

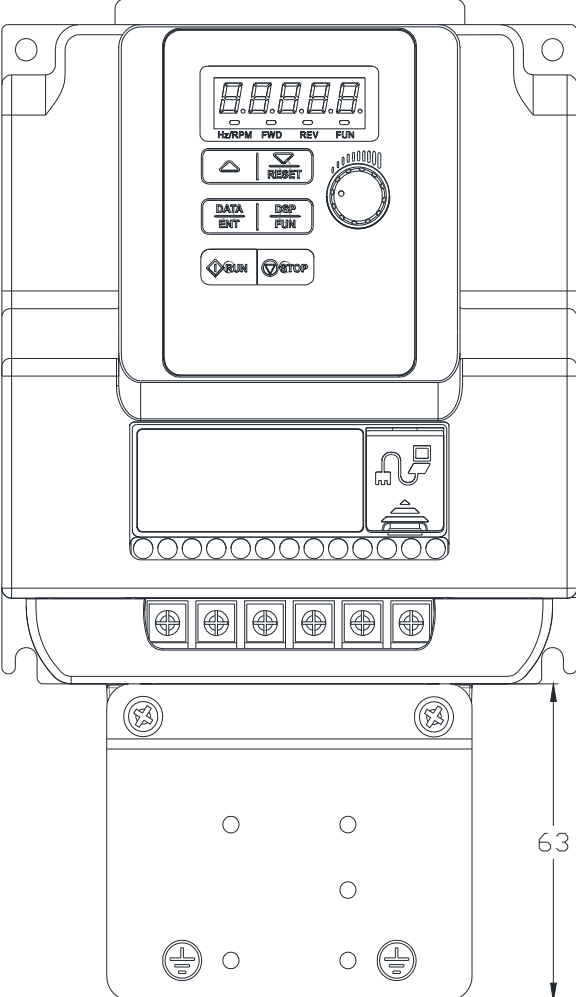

Grounding kit option installation diagram and instruction (Example)

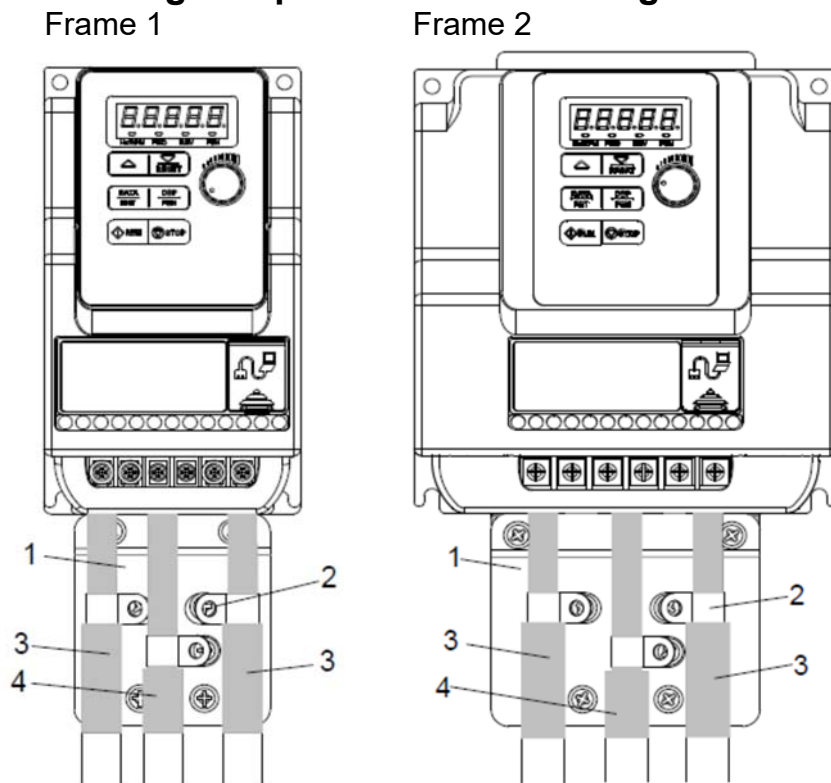

1. Grounding kit to be mounted on the drive, please follow the diagram to install .
2. Unshielded power supply lines or cable.
3. Unshielded wires or cable for the output of the relay contacts.
4. Attach and earth the shielding of cables 3 and 4 as close as possible to the drive:
 - Strip the cable to expose the shielding;
 - Attach the cable to the plate 1, attaching the clamp on the stripped part of the shielding. The shielding must be clamped tightly enough to metal sheet to ensure good contact.
5. Shielded power supply cable for connecting motor which connect to earth at both ends. The shielding must be continuous, and if intermediate terminals are used, they must be placed in EMC shielded metal boxes.
6. Shielded cable for control-signal wiring. For applications requiring several conductors, use cables with small cross-section (0.5 mm^2 , 20 AWG). For cables 3 and 4, the shielding must be connected to earth at both ends. The shielding must be continuous, and if intermediate terminals are used, they must be placed in EMC shielded metal boxes.

Notice :

- If using external EMC input filter, it must be mounted under the drive and connected directly to the line supply via an unshielded cable. Link 6 on the drive is then via the output cable.
- The HF equipotential earth connection between the drive, motor and cable shielding does not remove the need to connect the PE conductors  (green-yellow) to the appropriate terminals on each device.

3.2.3 De-rating curve

Curves below show the applicable output current de-rate due to setting of carrier frequency and the ambient operating temperatures of 40 and 50 degree C.

2P2/2P5/201 (40°C)

2P2/2P5/201 (50°C)(Note)

Note : 2P2/2P5/201 models without cooling fan design, 50 degrees de-rating curve for 5KHz carrier frequency operation only.

1P2/1P5(40°C)、202/203 (50°C)

208(50°C)

210(50°C)

401/2/3(50°C)

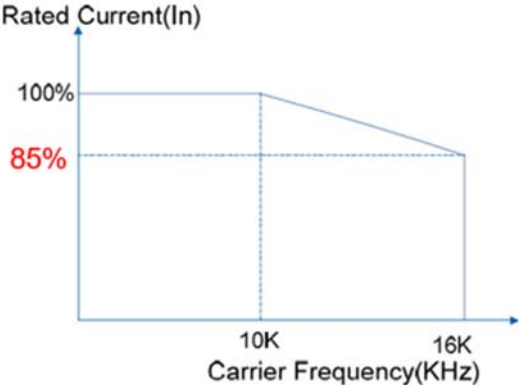

405(50°C)

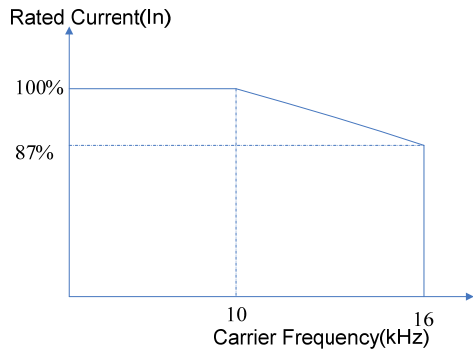

408(50°C)

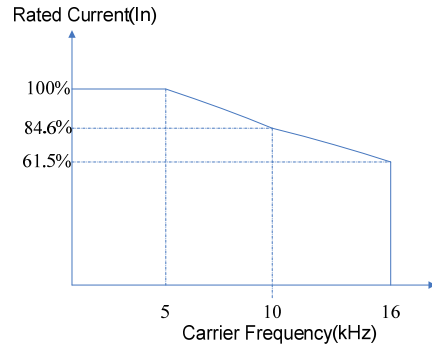

410(50°C)

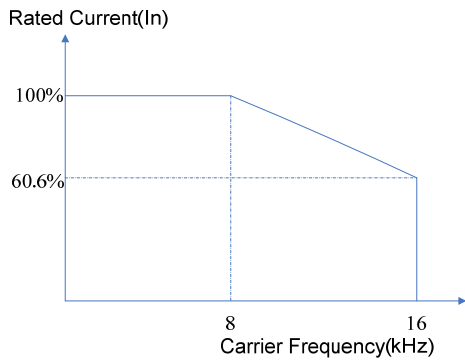

415(50°C)

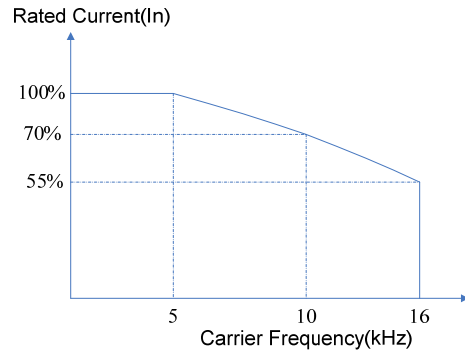

101/205(50°C)

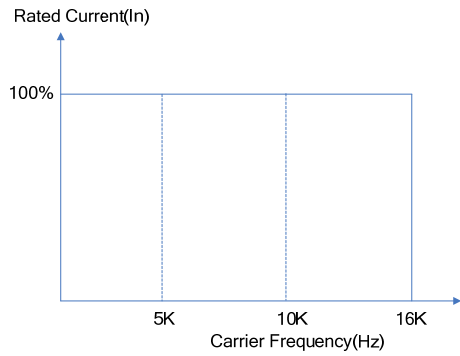

Note: 101 and 205 type does not need to decrease the current rating in 50 degrees ambient temperature.

3.2.4 Capacitor reforming Guide after long storage

For correct performance of this product after long storage before use it is important that Inverter Capacitors are reformed according to the guide below:

Storage time	Procedure to re-apply voltage
≤ 1 year	Apply rated voltage(Note1) of inverter in the normal way
Between 1-2 years	Apply rated voltage of inverter to the product for one hour before using the inverter
≥ 2 years	Use a variable AC power supply to 1. Connecting 25% rated voltage of inverter for 30 minutes. 2. Connecting 50% rated voltage of inverter for 30 minutes. 3. Connecting 75% rated voltage of inverter for 30 minutes. 4. Connecting 100% rated voltage of inverter for 210 minutes. Once the procedures completed, inverter just can be used normally.

Note1 : Rated voltage: please refer the rated voltage according to model label of inverter.

3.3 Wiring Guidelines

3.3.1 Main considerations

- 1 Tightening Torque for Screw terminals : Refer to the tables 3-1, when using a screwdriver or any other suitable tools to make connections.
- 2 Power terminals:
Single phase : L1 (L), L3 (N)
Three-phase 200V models: L1 (L), L2, L3 (N)
400V models: L1, L2, L3
- 3 For all cabling use copper wires and the cable size shall be according to the table below rated at 105 degrees Celsius.
- 4 Power & Control cable Minimum rated voltage
240V AC system, 300V AC.
480V AC system, 600V AC.
- 5 Control cables should be separated from the power cables. Do not place them in the same cable tray or cable trunking to prevent against electrical interference.

Table 3-1

Frame size	TM1					TM2				
	Cable Size		Tightening torque			Cable Size		Tightening torque		
	AWG	mm ²	kgf.cm	lbf.in	Nm	AWG	mm ²	kgf.cm	lbf.in	Nm
Frame1	22~10	0.34~6	14	12.15	1.37	24~12	0.5~2.5	4.08	3.54	0.4
Frame2			12.24	10.62	1.2					
Frame3	18~8	0.82~8.4	18	15.58	1.76	24~12	0.5~2.5	5.1	4.43	0.5
Frame4	14~6	2~13.3	24.48	21.24	2.4					

- 6 The maximum RMS symmetrical Current Ratings and voltage are listed as below:

Device Rating		Short circuit Rating	Maximum Voltage
voltage	HP		
110V	0.2~1	5000A	120V
220V	0.2~10	5000A	240V
440V	1~15	5000A	480V

- 7 Electrical ratings of terminals:

Horsepower	Power Specification	Voltage (Volt)	Current(A)
0.25/0.5/1	220~240V	300	30
1	100~120V		20
2/3	220~240V		30
1/2/3	380~480V	600	28
5	220~240V	300	45
7.5/10	220~240V	300	65
5.5/7.5	380~480V	600	45
10/15	380~480V	600	65

3.3.2 Power Cables.

Supply power cable must be connected to TM1 terminal block, terminals L1(L) and L3(N) for single phase 200V supply, L1(L), L2, L3(N) for three phase 200V supply and L1, L2, L3 for three phase 400V supply.

Motor cable must be connected to TM1 terminals. T1, T2, T3.

Warning:- Connection of Supply line cable to terminals T1,T2& T3 will result in serious damage to the drive components.

Example power connections:- Inverter with dedicated power line.

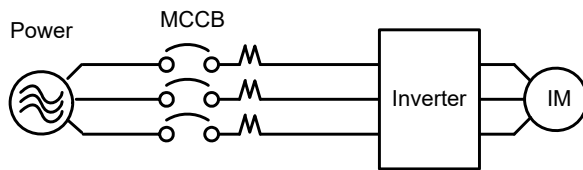

- Install a Supply RFI filter or Isolation transformer when the power source is shared with other high power electrical equipment as shown below.

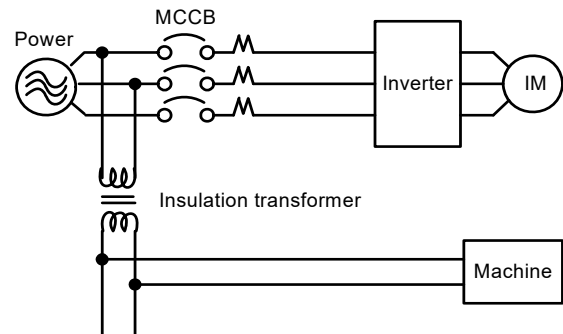
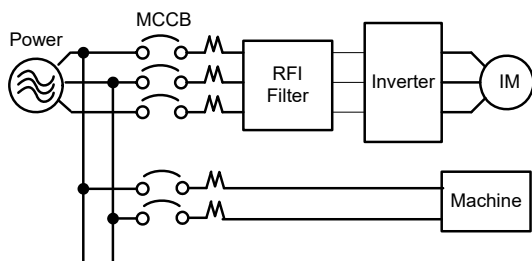

3.3.3 Control Cable selection and Wiring.

Control cables should be connected to terminal block TM2.

Choose power & Control cables according to the following criteria:-

- Use copper wires with correct diameter and temperature rating of 60/75°C.
- Minimum cable voltage rating for 200V type inverters should be 300VAC.
- Route all cables away from other high voltage or high current power lines to reduce interference effects.

Use a twisted pair shielded cable and connect the shield (screen) wire to the ground terminal at the inverter end only. Cable length should not exceed 50 meters.

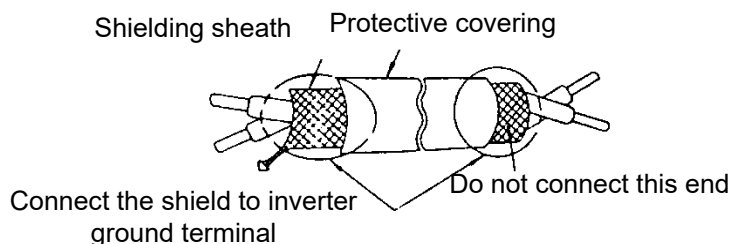

3.3.4 Wiring and EMC guidelines.

For effective interference suppression, do not route power and control cables in the same conduit or trunking.

To prevent radiated noise, motor cable should be put in a metal conduit. Alternatively an armored or shielded type motor cable should be used.

For effective suppression of noise emissions the cable armor or shield must be grounded at both ends to the motor and the inverter ground. These connections should be as short as possible.

Motor cable and signal lines of other control equipment should be at the least 30 cm apart.

L510s has a built in Class "A" EMC filter to first Environment Restricted. (Category C2).

For some installations such as residential,(Category C1) an optional external Class "B" type filter will be necessary. Please consult your local supplier.

Typical Wiring.

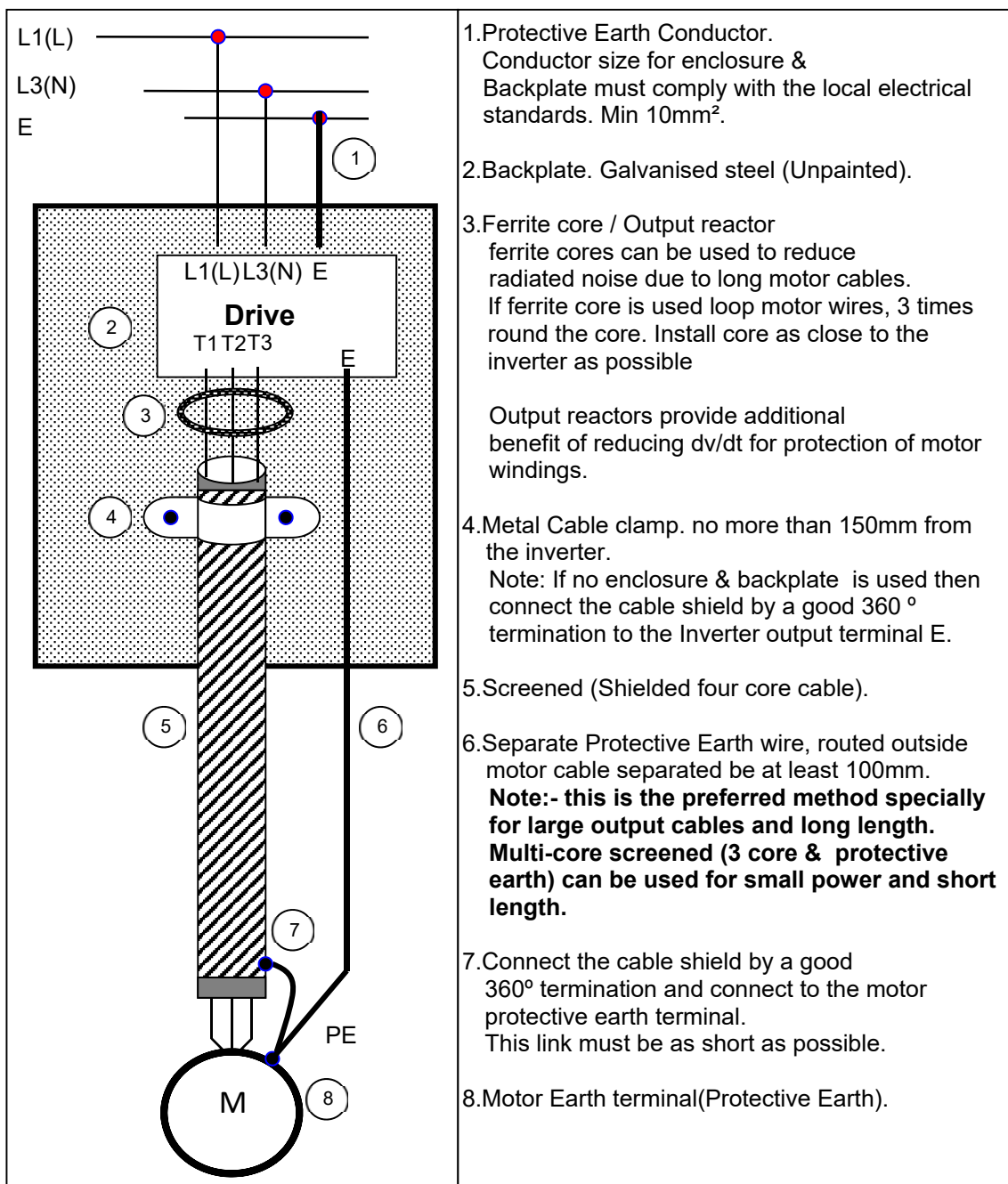

3.3.5 Failure liability

- Teco bears no responsibility for any failures or damaged caused to the inverter if the recommendations in this instruction manual have not been followed specifically points listed below,
- If a correctly rated fuse or circuit breaker has not been installed between the power source and the inverter.
- If a magnetic contactor, a phase capacitor, burst absorber and LC or RC circuits have been connected between the inverter and the motor.
- If an incorrectly rated three-phase squirrel cage induction motor has been used

Note:

When one inverter is driving several motors, the total current of all motors running simultaneously must be less than the rated current of the inverter, and each motor has to be equipped with a correctly rated thermal overload relay.

3.3.6 Considerations for peripheral equipment

	<p>Power</p>	<p>Ensure that the supply voltage is correct. A molded-case circuit breaker or fused disconnect must be installed between the AC source and the inverter</p>
<p>Circuit Breaker & RCD</p>	<p>Use a molded-case circuit breaker that conforms to the rated voltage and current of the inverter. Do not use the circuit breaker as the run/stop switch for the inverter. Residual Current Circuit Breaker(RCD) Current setting should be 200mA or above and the operating time at 0.1 second or longer to prevent malfunctions.</p>	
<p>Magnetic contactor</p>	<p>Normally a magnetic contactor is not needed. A contactor can be used to perform functions such as external control and auto restart after power failure. Do not use the magnetic contactor as the run/stop switch for the inverter.</p>	
<p>AC reactor for power quality improvement</p>	<p>When a 200V/400V inverter with rating below 15KW is connected to a high capacity power source (600kVA or above) then an AC reactor can be connected for power factor improvement and reducing harmonics.</p>	
<p>Input noise filter</p>	<p>Inverter has a built-in filter to Class "A" first Environment. (CategoryC2) To satisfy the required EMC regulations for your specific application you may require an additional EMC filter.</p>	
<p>Inverter</p>	<p>Connect the single phase power to Terminals, L1(L) & L3(N) and three phase power to Terminals : (200V : L1(L),L2,L3(N) or 400V : L1,L2,L3) Warning! Connecting the input terminals T1, T2, and T3 to AC input power will damage the inverter. Output terminals T1, T2, and T3 are connected to U, V, and W terminals of the motor. To reverse the motor rotation direction just swap any two wires at terminals T1, T2, and T3. Ground the Inverter and motor correctly. Ground Resistance for 200V power < 100 Ohms.</p>	
<p>Motor</p>	<p>Three-phase induction motor. Voltage drop on motor due to long cable can be calculated. Volts drop should be < 10%. Phase-to-phase voltage drop (V) = $\sqrt{3} \times \text{resistance of wire } (\Omega/\text{km}) \times \text{length of line (m)} \times \text{current} \times 10^{-3}$</p>	

(For detailed information for the above peripheral equipment refer to Chapter 6)

3.3.7. Ground connection

Inverter Ground terminal must be connected to installation ground correctly and according to the required local wiring regulations.

- Ground cable size must be according to the required local wiring regulations. Ground connection should be as short as possible.
- Do not share the ground of the inverter with other high current loads (Welding machine, high power motors). Ground each unit separately.
- Ensure that all ground terminals and connections are secure
- Do not make ground loops when several inverters share a common ground point.

Note: Please leave at least 5cm while installing inverter side by side in order to provide enough cooling space.

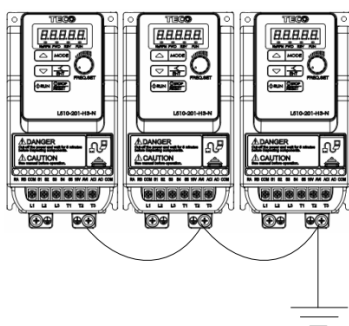

(a) Correct

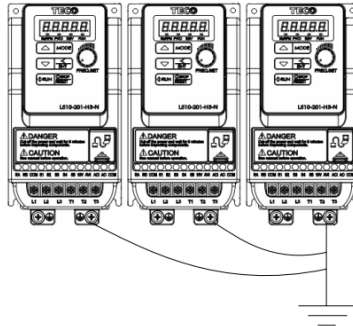

(b) Correct

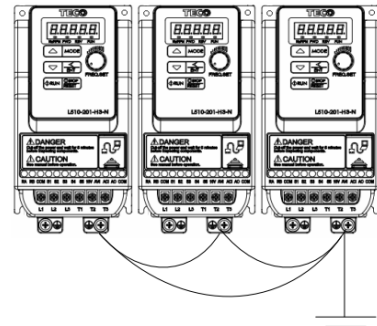

(c) Incorrect

3.4 Specifications

3.4.1 Product Specifications

100V Class : Single phase

Model : L510-□□□-SH1-N/P	1P2	1P5	101
Horse power (HP)	0.25	0.5	1
Suitable motor capacity (kW)	0.2	0.4	0.75
Rated output current (A)	1.8	2.6	4.3
Rated capacity (kVA)	0.68	1.00	1.65
Input voltage range(V)	Single Phase : 100~120V(+10%-15%),50/60HZ		
Output voltage range(V)	Three phase 0~240V		
Input current (A)*	9.5	13	19
Weight(Kg)	0.9	0.9	1.4
Allowable momentary power loss time (s)	1.0	1.0	1.0
Enclosure	IP20		

200V Class : Single phase.

F : Standards for built-in filter

Model : L510-□□□-SH1X-N/P	2P2	2P5	201	202	203
Horse power (HP)	0.25	0.5	1	2	3
Suitable motor capacity (kW)	0.2	0.4	0.75	1.5	2.2
Rated output current (A)	1.8	2.6	4.3	7.5	10.5
Rated capacity (kVA)	0.68	1.00	1.65	2.90	4.00
Input voltage range(V)	Single Phase : 200~240V(+10%-15%),50/60HZ				
Output voltage range(V)	Three phase 0~240V				
Input current (A)	4.9	7.2	11	15.5	21
Weight(kG)	0.9	0.9	0.9	1.4	1.4
Weight with filter(kG)	1.0	1.0	1.0	1.5	1.5
Allowable momentary power loss time (s)	1.0	1.0	1.0	2.0	2.0
Enclosure	IP20				

200V Class : Three phase

Model : L510-□□□-SH3-N/P	2P2	2P5	201	202	203
Horse power (HP)	0.25	0.5	1	2	3
Suitable motor capacity (kW)	0.2	0.4	0.75	1.5	2.2
Rated output current (A)	1.8	2.6	4.3	7.5	10.5
Rated capacity (kVA)	0.68	1.00	1.65	2.90	4.00
Input voltage range(V)	Three phase : 200~240V(+10%-15%),50/60HZ				
Output voltage range(V)	Three phase 0~240V				
Input current (A)	3.0	4.0	6.4	9.4	12.2
Weight(kG)	0.9	0.9	0.9	1.4	1.4
Allowable momentary power loss time (s)	1.0	1.0	1.0	2.0	2.0
Enclosure	IP20				

Model : L510-□□□-SH3	205	208	210
Horse power (HP)	5	7.5	10
Suitable motor capacity (kW)	3.7	5.5	7.5
Rated output current (A)	17.5	26	35
Rated capacity (kVA)	6.67	9.91	13.34
Input voltage range(V)*	Three phase : 200~240V (+10%-15%),50/60HZ		
Output voltage range(V)	Three phase 0~240V		
Input current (A)	19.3	28.6	38.5
Weight(kG)	2.2	6.3	6.3
Allowable momentary power loss time (s)	2.0	2.0	2.0
Enclosure	IP20		

400V Class : Three phase.

F : Standards for built-in filter

Model : L510-□□□-SH3-N/P L510-□□□-SH3F-P	401	402	403
Horse power (HP)	1	2	3
Suitable motor capacity (kW)	0.75	1.5	2.2
Rated output current (A)	2.3	3.8	5.2
Rated capacity (kVA)	1.7	2.9	4.0
Input voltage range(V)	Three Phase : 380~480V (+10%-15%),50/60HZ		
Output voltage range(V)	Three phase 0~480V		
Input current (A)	4.2	5.6	7.3
Weight(kG)	1.4	1.4	1.4
Weight with filter(kG)	1.5	1.5	1.5
Allowable momentary power loss time (s)	2.0	2.0	2.0
Enclosure	IP20		

*The input current is calculated value at full rated output current.

Model : L510-□□□-SH3 L510-□□□-SH3F	405	408	410	415
Horse power (HP)	5	7.5	10	15
Suitable motor capacity (kW)	3.7	5.5	7.5	11
Rated output current (A)	9.2	13.0	17.5	24
Rated capacity (kVA)	7.01	9.91	13.34	18.29
Input voltage range(V)	Three Phase :380~480V (+10%-15%),50/60HZ			
Output voltage range(V)	Three Phase 0~480V			
Input current (A)	10.1	14.3	19.3	26.4
Weight(kG)	2.2	2.2	6.3	6.3
Weight with filter(kG)	2.4	2.4	6.3	6.3
Allowable momentary power loss time (s)	2	2	2	2
Enclosure	IP20			

F : Built-in EMC filter.

3.4.2 General Specifications

Item		L510s
Control Mode		V/F Control + SLV control
Frequency	Range	0.01~599.00Hz
	Speed accuracy (100% torque)	V/F: 3% SLV: 1%
	Starting Torque	V/F: 3Hz / 100% SLV: 3Hz / 150%
	Setting resolution	Digital input : 0.01Hz Analog input : 0.015Hz/60Hz
	Frequency Setting	Keypad : Set directly with ▲ ▼ keys or the VR (Potentiometer) on the keypad External Input Terminals: AVI(0/2~10V), ACI(0/4~20mA) analog input Multifunction input up/down function(Group3) Setting frequency by Communication method. Remote control: Set directly with ▲ ▼ keys of remote keypad
	Frequency limit	Lower and upper frequency limits, 3 -skip frequency settings.
Run	Operation set	Keypad run, stop button External terminals: Multi- operation-mode 2 / 3 wire selection Jog operation Run signal by communication method. Remote control: Set directly with run, stop button of remote keypad
Main Controls	V / F curve setting	6 fixed curve and one customized curve
	Carrier frequency	1~16kHz(default 5kHz)
	Acceleration and deceleration control	2 off Acc / dec time parameters, 4 off S curve parameters.
	Multifunction input	19 functions (refer to description on group3) 5 points, Frame1/2 : NPN&PNP by separate models Frame 3/4 : NPN&PNP switchable
	Multifunction output	16 functions (refer to description on group3)
	Multifunction analog output	5 functions (refer to description on group4), 1 point (0~10V)
	Main features	Overload Detection, 8 Preset speeds, Auto-run, Acc/Dec Switch (2 Stages), Main/Alt run Command select, Main/Alt Frequency Command select, PID control, torque boost, V/F start Frequency ,Fault reset. Constant Pressure and Multi-Pump Parallel Connection Function.
	Efficiency	Meet IEC/EN 61800-9-2 IE2 Class
Display	LED	Display: parameter/parameter value/frequency/line speed/DC voltage/output voltage/output current/PID feedback/input and output terminal status/Heat sink temperature/Program Version/Fault Log.
	LED Status Indicator	For run/stop/forward and reverse.

RProtective Functions	Overload Protection	Integrated motor and Inverter overload protection. (150% rated current for 60sec, every 10 minutes)
	Over voltage	100V/200V : Over 410V, 400V : Over 820V
	Under voltage	100V/200V : Under 190V, 400V : Under 380V
	Momentary Power Loss Restart	Inverter auto-restart after a momentary power loss.
	Stall Prevention	Stall prevention for Acceleration/ Deceleration/ and continuous Run.
	Short-circuit output terminal	Electronic Circuit Protection
	Grounding Fault	Electronic Circuit Protection
	Additional protective functions	heatsink over temperature protection, Auto carrier frequency reduction with temperature rise, fault output, reverse prohibit, Number of auto restart attempts, Parameter lock, over voltage protection(OVP), motor PTC over-temperature protection
International Certification		CE /UL /cUL / UKCA/ RCM
Communication		RS485 (Modbus) built in, with one to one or one to many control. Built-in BacNet communication. Profibus, DeviceNet, CANopen, TCP/IP and EtherNet/IP by gateways. Built-in Constant Pressure and Multi-Pump Parallel Connection Function.
Environment	Operating temperature	-10~50°C(with fan), -10~40°C(without fan)
	Storage temperature	-20~60°C
	Humidity	Under 95%RH (no condensation)
	Vibration	Frequency: 10Hz - 150Hz - 10Hz Amplitude(0.3mm): $10\text{Hz} \leq f \leq 57\text{Hz}$ Acceleration(2G): $57\text{Hz} \leq f \leq 150\text{Hz}$ (According to IEC60068-2-6 standard)
	EMC Compliance	EN61800-3, First Environment (Use of the optional grounding kit is recommended to achieve compliance.).
	LVD Compliance	EN 61800-5-1
	Electrical Safety	UL508C
	Protection level	IP20

3.5 Standard wiring

3.5.1 Single phase (NPN) input

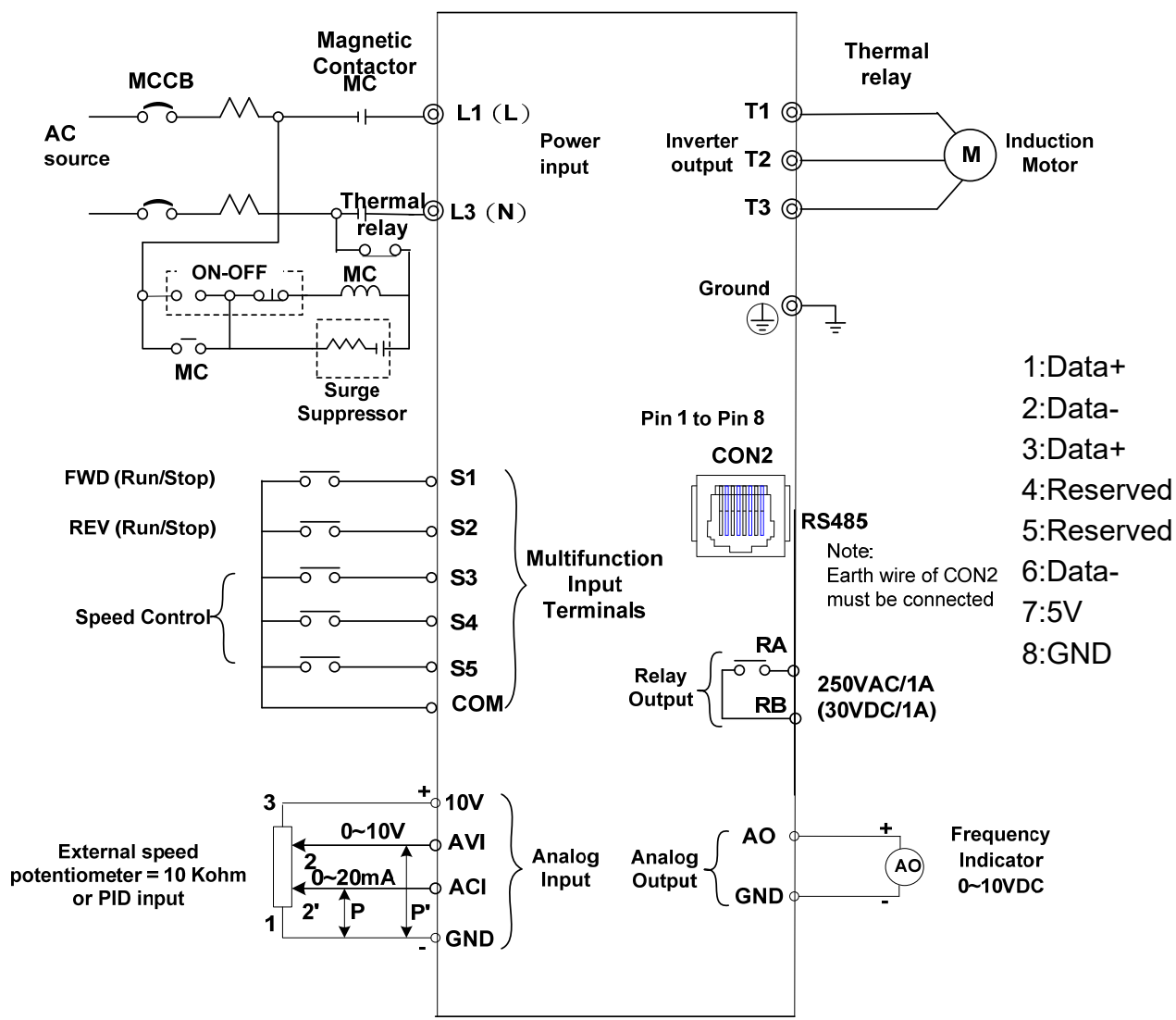

Model:

- 100V : L510-1P2-SH1-N, L510-1P5-SH1-N, L510-101-SH1-N
- 200V : L510-2P2-SH1(F)-N, L510-2P5-SH1(F)-N,
L510-201-SH1(F)-N, L510-202-SH1(F)-N, L510-203-SH1(F)-N

3.5.2 Single phase(PNP) input

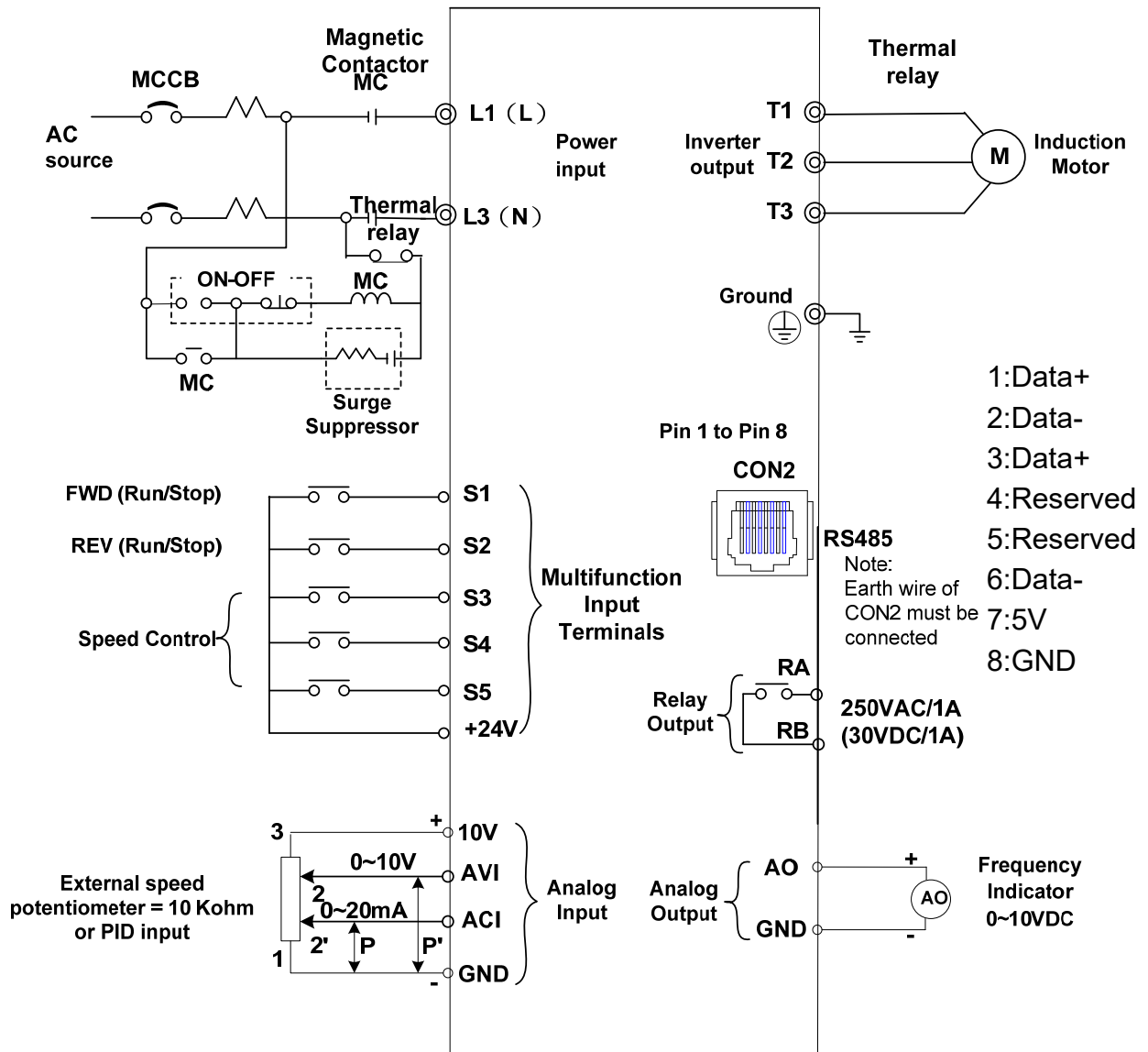

Model:

200V : L510-2P2-SH1(F)-P, L510-2P5-SH1(F)-P,
L510-201-SH1(F)-P, L510-202-SH1(F)-P, L510-203-SH1(F)-P

3.5.3 Three phase (NPN) input

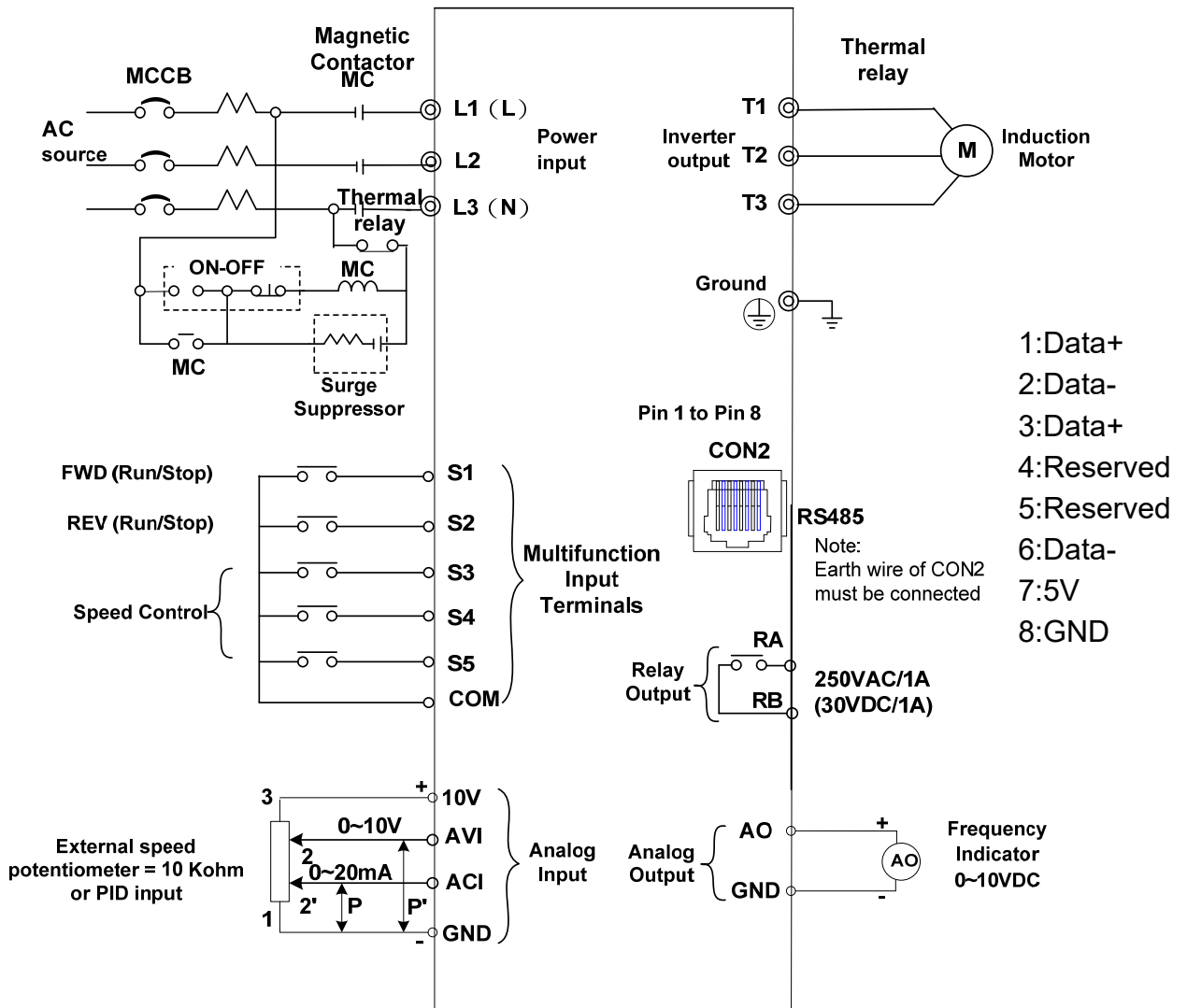

Model:

200V : L510-2P2-SH3-N, L510-2P5-SH3-N, L510-201-SH3-N
 L510-202-SH3-N, L510-203-SH3-N

400V : L510-401-SH3-N, L510-402-SH3-N, L510-403-SH3-N

3.5.4 Three phase (PNP) input

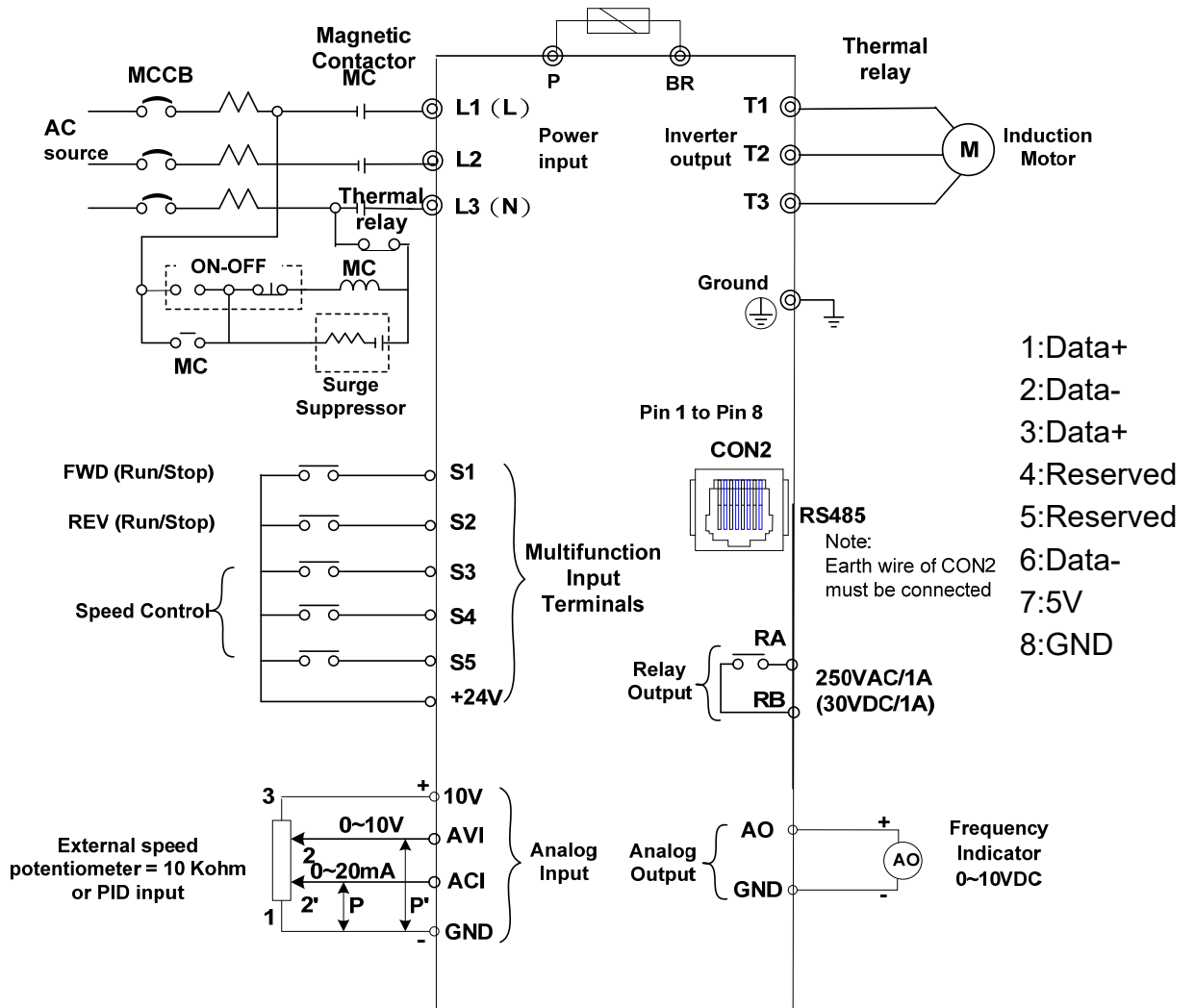

Model:

400V : L510-401-SH3(F)-P, L510-402-SH3(F)-P, L510-403-SH3(F)-P

3.5.5 NPN/PNP selectable models

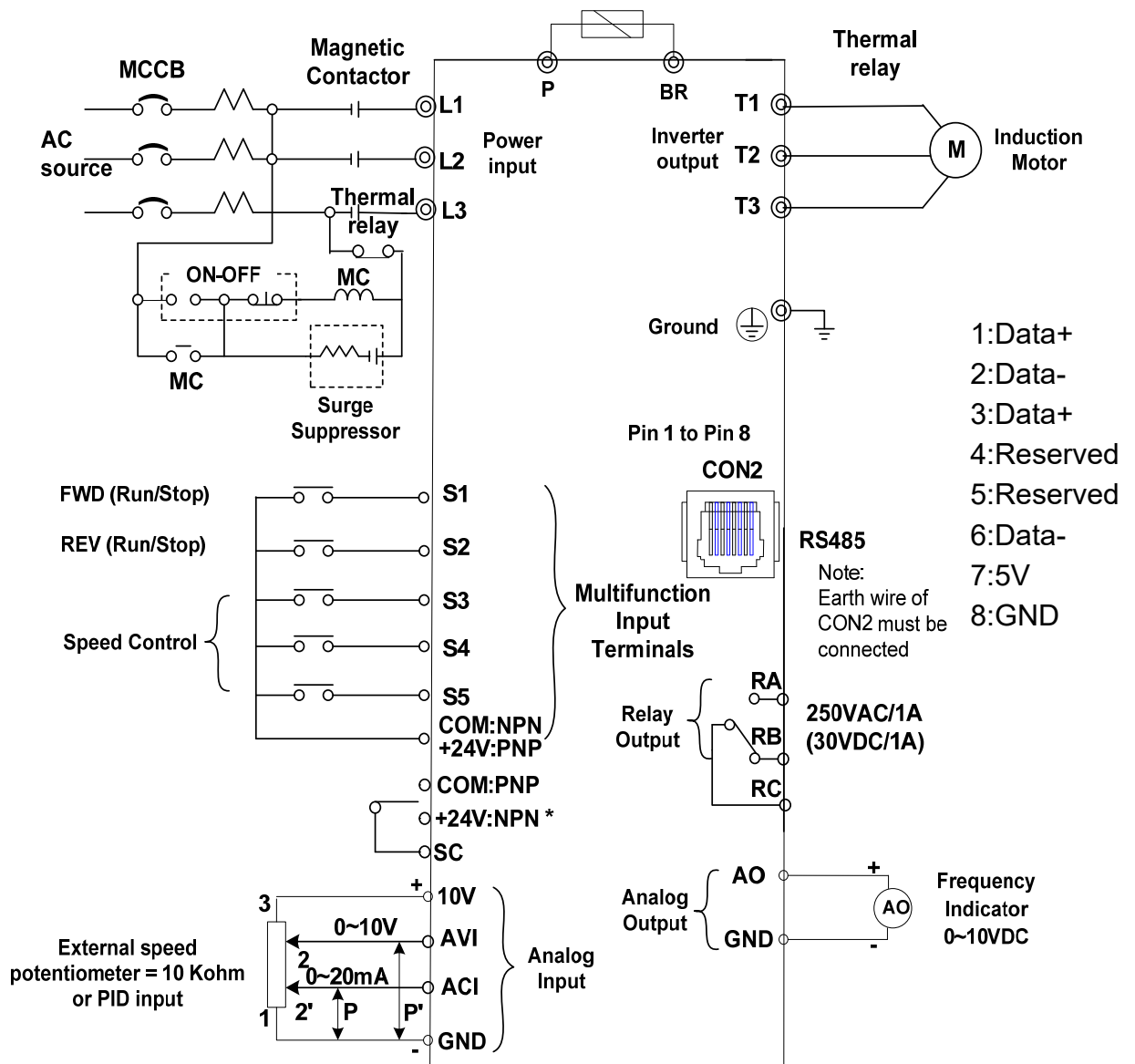

Model:

- 200V : L510-205-SH3, L510-208-SH3, L510-210-SH3
- 400V : L510-405-SH3(F), L510-408-SH3(F), L510-410-SH3(F), L510-415-SH3(F)

NPN/PNP input type selection

- PNP:** 1.Link SC and COM terminal
2.Use +24v terminal for S1~S5 common point
- NPN:** 1.Link SC and +24V terminal
2.Use COM terminal for S1~S5 common point

Note:

Please ensure correct connection before setting parameter group 3 digital inputs.

3.5.6 Single/Multi-Pump Dedicated Wiring Diagram (When 14-00=1)

(For example: NPN input type)

PUMP Wiring Diagram for Pressure sensor of Current Type:

Single Pump:

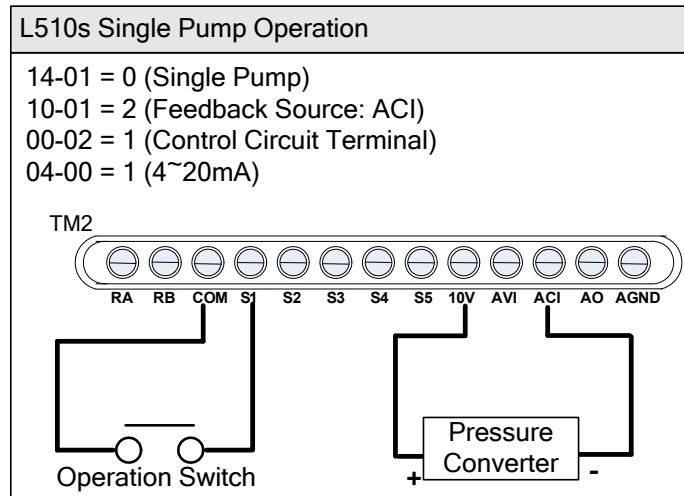

Multi-Pump:

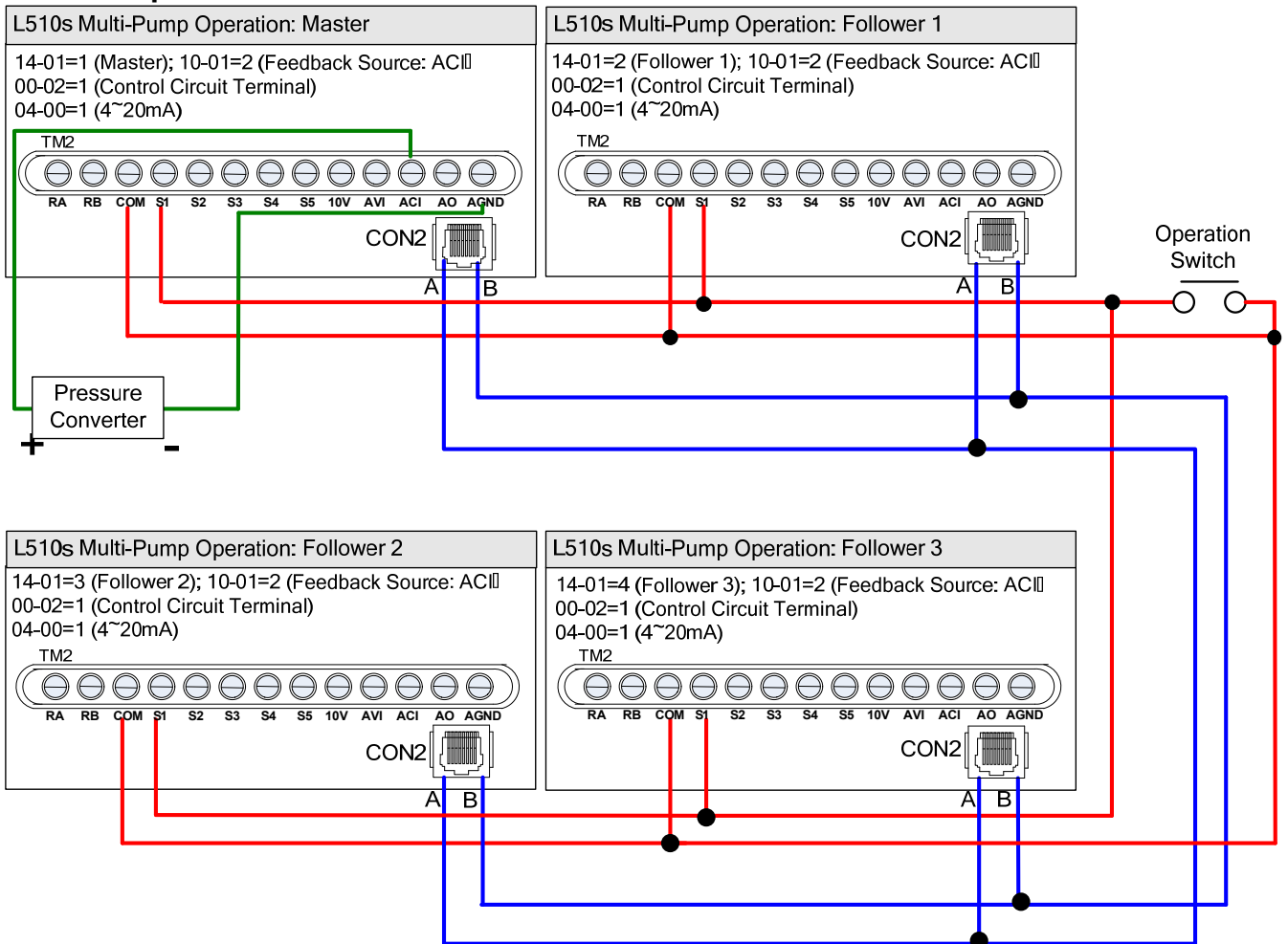

**PUMP Wiring Diagram for Pressure sensor of Voltage Type:
Single Pump:**

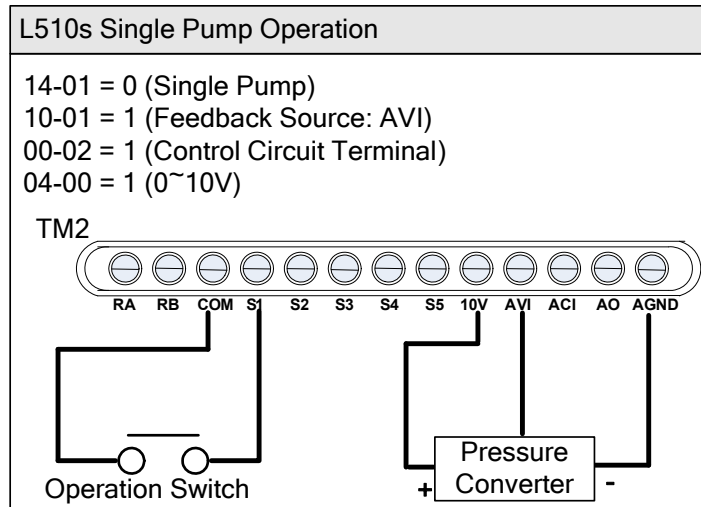

Multi-Pump:

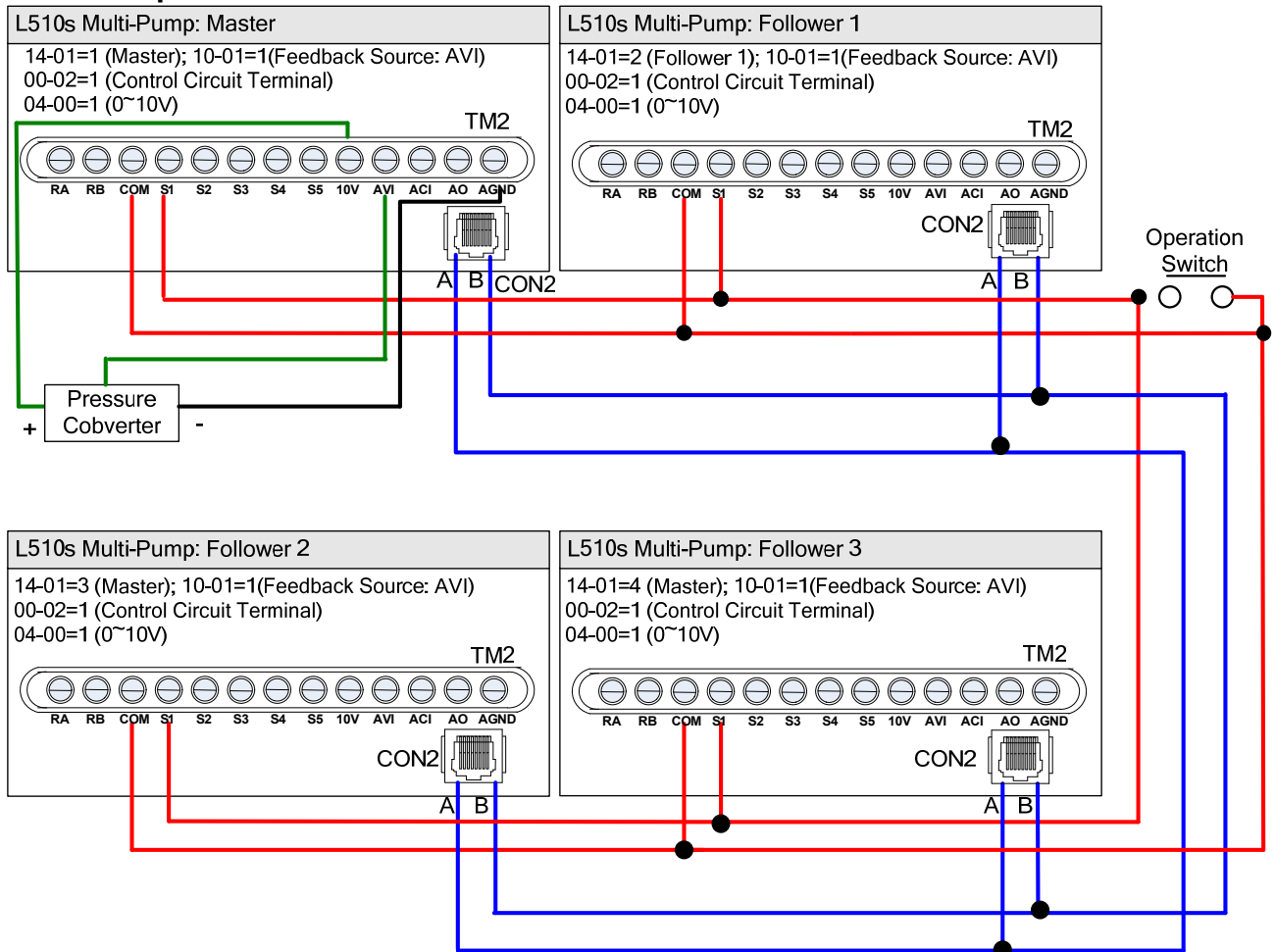

Notes:

1. It is required to reconnect after setting Master and Slave.
2. It is required to short the COM and AGND port of frame3 and frame 4 when pressure converter connected with +24Vpower supply.
3. When the communication modes is selected to be multiple pumps in parallel connection, the baud rate setting 09-02 of Master and Slave are required to be consistent. Refer to parameter 14-31 for the actions in parallel connection modes.

3.6 Terminal Description

3.6.1 Description of main circuit terminals

Terminal symbols	TM1 Function Description
L1(L)	Main power input Single phase: L1(L) / L3(N) Three phase(200V): L1(L) / L2 / L3(N) Three phase(400V): L1 / L2 / L3
L2	
L3(N)	
P*	externally connected braking resistor
BR*	
T1	Inverter output, connect to U, V, W terminals of motor
T2	
T3	
⊥	Ground terminal

*P, BR for 205/208/210/401/402/403/405/408/410/415 models only

Single phase

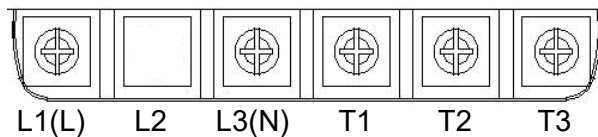

Note: the screw on L2 terminal is removed for the single phase input supply models.

Three phase (200V series)

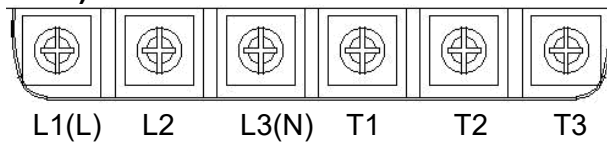

Three phase (205 & 208 & 210 & 400V series)

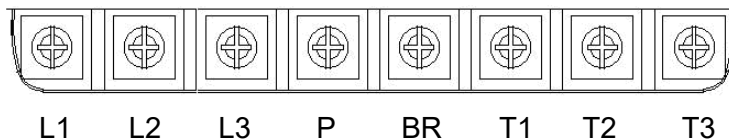

3.6.2 Description of control circuit terminals Frame1&Frame2

Terminal symbols	TM2 Function Description	Signal Level
RA	Relay output terminal, Specification: 250VAC/1A(30VDC/1A)	250VAC/1A(30VDC/1A)
RB		
COM	S1~S5 (common point) 【NPN】	±15%,Max output current 30mA
24V	S1~S5 (common point) 【PNP】	
S1~S5	Multi-function input terminals(refer to group3)	24 VDC, 4.5 mA, optical coupling isolation (Max,voltage30 VDC, Input impedance 6kΩ)
10V	Built in power for an external speed potentiometer	10V,(Max current:20mA)
AVI	Analog voltage input, Specification : 0/2~10VDC (selected by parameter 04-00)	0~10V(Input impedance 200kΩ)
ACI	Analog current input, Specification : 0/4~20mA (selected by parameter 04-00)	0~20mA(Input impedance 249Ω)
AO	Multi-function analog output terminal. Maximum output 10VDC/1mA	0~10V(Max current 2mA)
AGND	Analog ground terminal	

NPN:

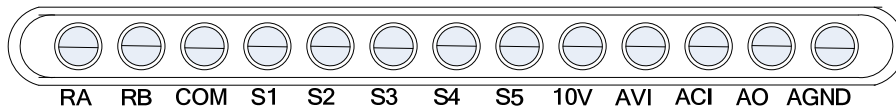

PNP:

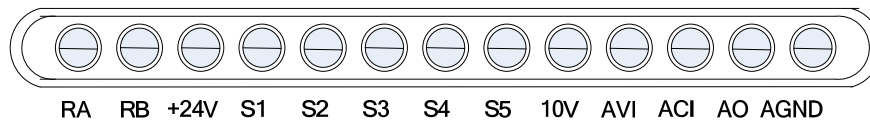

Frame3&Frame4

Terminal symbols	TM1 Function Description
RA	Relay output terminal, Specification: 250VAC/5A(30VDC/5A) RA: Normally open RB: Normally close RC: common point
RB	
RC	

Terminal symbols	TM2 Function Description	Signal Level
+24V	Common point of PNP input	±15%,Max output current 30mA
SC	NPN/PNP selectable terminal. NPN input: +24V&SC need to be shorted. PNP input: COM&SC need to be shorted.	
COM	voltage reference point for S1~S5	
S1~S5	Multi-function input terminals(refer to group3)	24 VDC, 4.5 mA, Optical coupling isolation (Max,voltage30 Vdc, Input impedance 6kΩ)
10V	Built in Power for an external speed potentiometer (Max output : 20mA)	10V,(Max current:20mA)
AVI/PTC	Analog voltage input and motor over temperature protection signal input, Specification : 0/2~10VDC	0~10V(Input impedance 200kΩ)
ACI	Analog current input, Specification : 0 /4~20mA(choose by parameter 04-00)	0~20mA(Input impedance 249Ω)
AO	Multi function analog output terminal. Maximum output 10VDC/1mA	0~10V(Max current 2mA)
AGND	Analog ground terminal	

NPN/PNP control terminals:

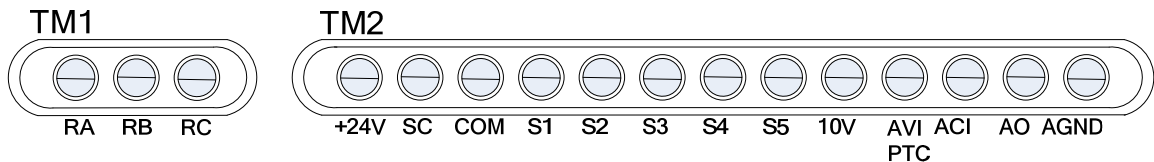

3.7 Outline Dimensions(unit: mm)

Tolerance Table				
0~6±0.8	6~30±1.5	30~120±2.5	120~315±4.0	315~1000±6.0

Frame1

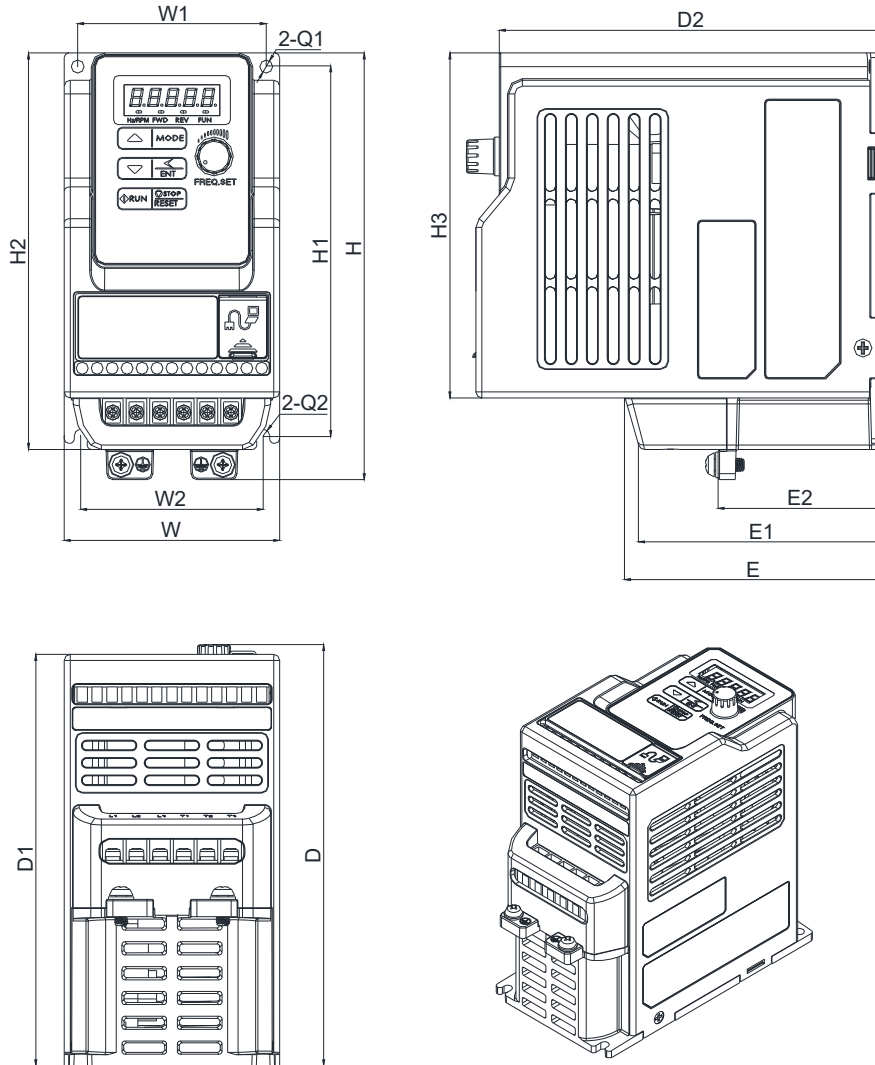

Model	dimension														
	W	W1	W2	H	H1	H2	H3	D	D1	D2	E	E1	E2	Q1	Q2
L510-1P2-SH1-N/P	72	63	61	141	122	131	114	141	136	128	86	81	55	4.4	2.2
L510-1P5-SH1-N/P															
L510-2P2-SH1-N/P															
L510-2P5-SH1-N/P															
L510-201-SH1-N/P															
L510-2P2-SH1F-P															
L510-2P5-SH1F-P															
L510-2P7-SH1F-P															
L510-201-SH1F-P															
L510-2P2-SH3-N/P															
L510-2P5-SH3-N/P															
L510-201-SH3-N/P															

F : Built-in EMC filter

Frame2 100V/200V

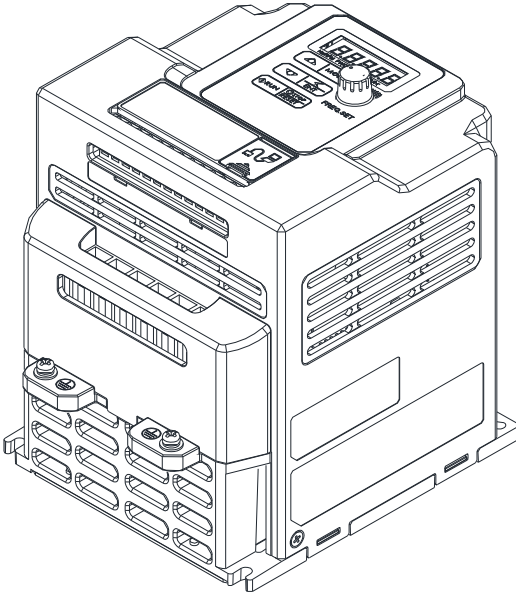
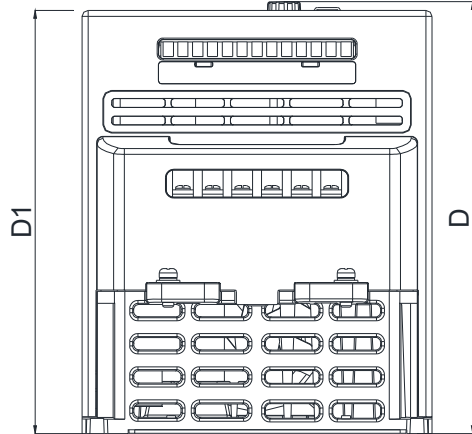
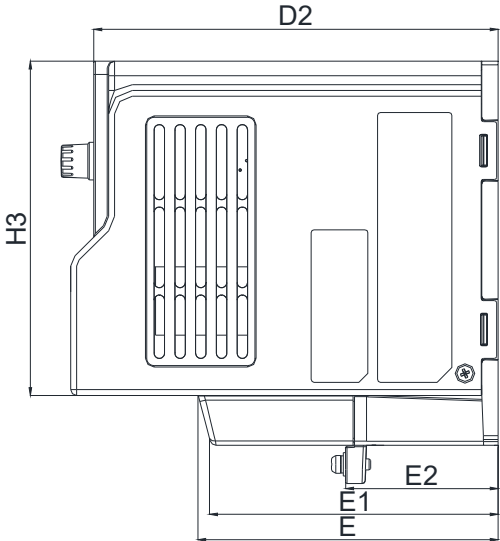
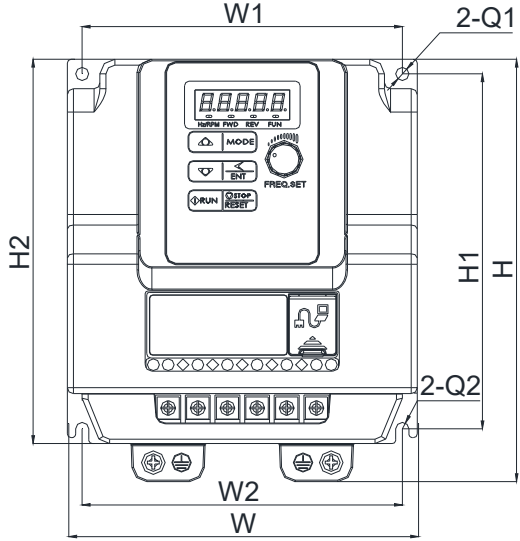

Model	dimension														
	W	W1	W2	H	H1	H2	H3	D	D1	D2	E	E1	E2	Q1	Q2
L510-101-SH1-N/P	118	108	108	144	121	131	114	150	144	136	101	96	51	4.4	2.2
L510-202-SH1-N/P															
L510-203-SH1-N/P															
L510-202-SH1F-P															
L510-203-SH1F-P															
L510-202-SH3-N/P															
L510-203-SH3-N/P															

F : Built-in EMC filter

Frame2 400V

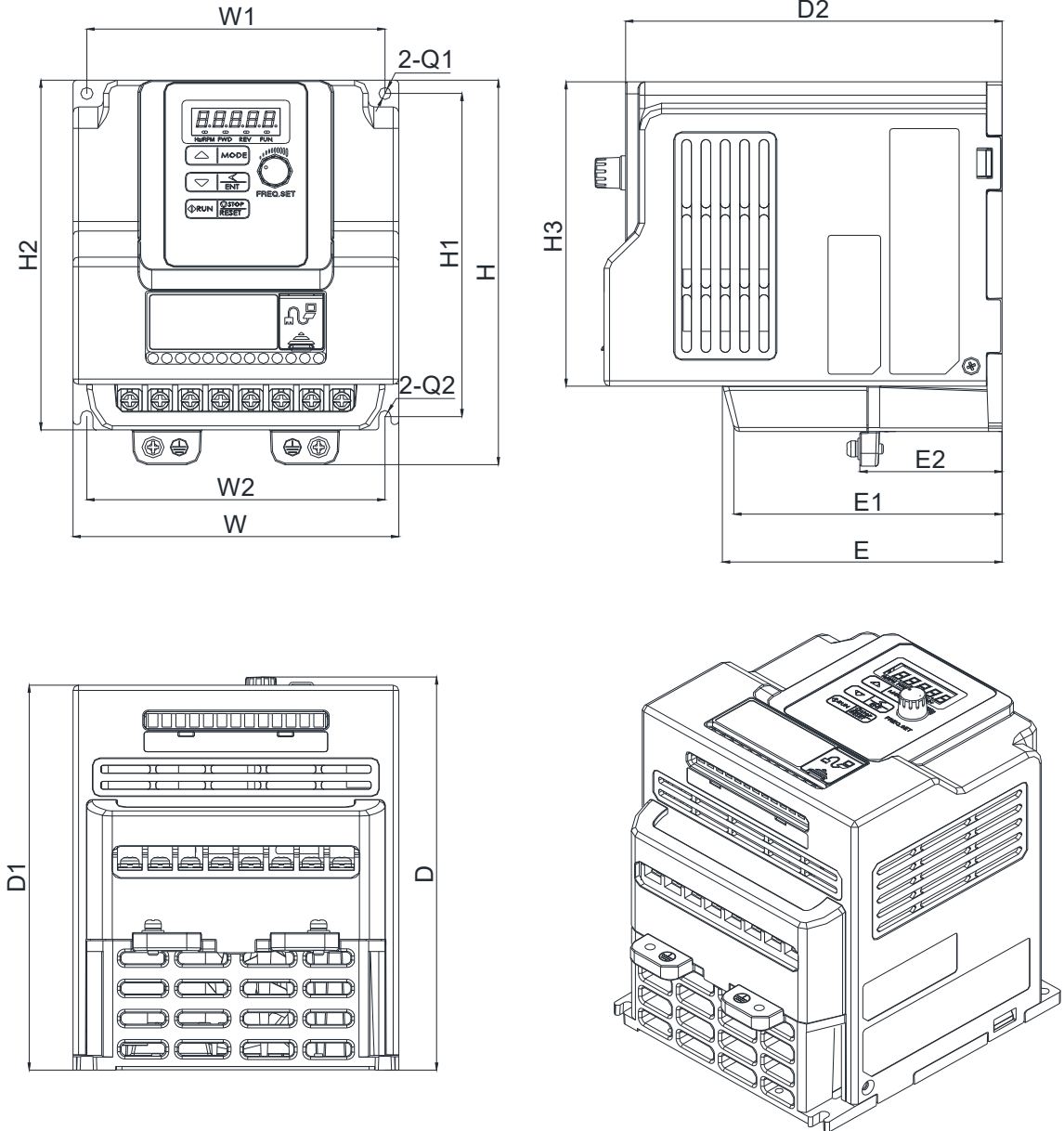

Model	dimension														
	W	W1	W2	H	H1	H2	H3	D	D1	D2	E	E1	E2	Q1	Q2
L510-401-SH3-N/P	118	108	108	144	121	131	114	150	144	136	101	96	51	4.3	2.2
L510-402-SH3-N/P															
L510-403-SH3-N/P															
L510-401-SH3F-P															
L510-402-SH3F-P															
L510-403-SH3F-P															

F : Built-in EMC filter

Frame3

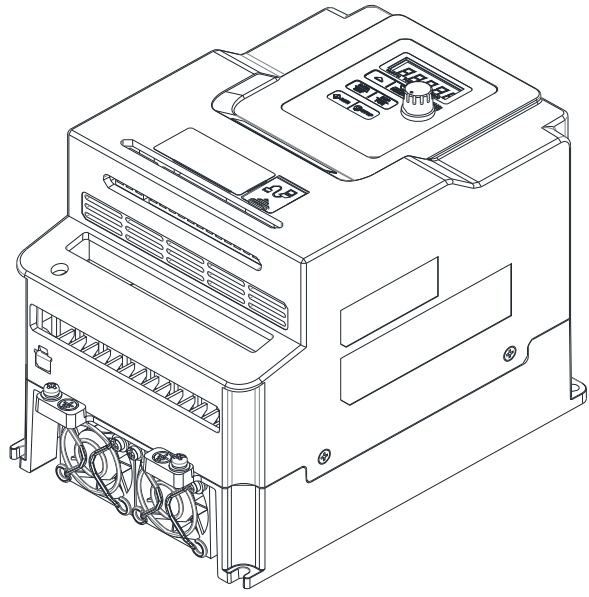
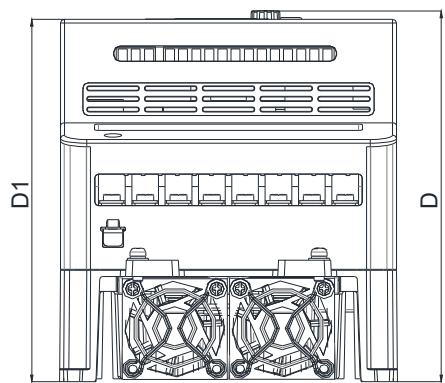
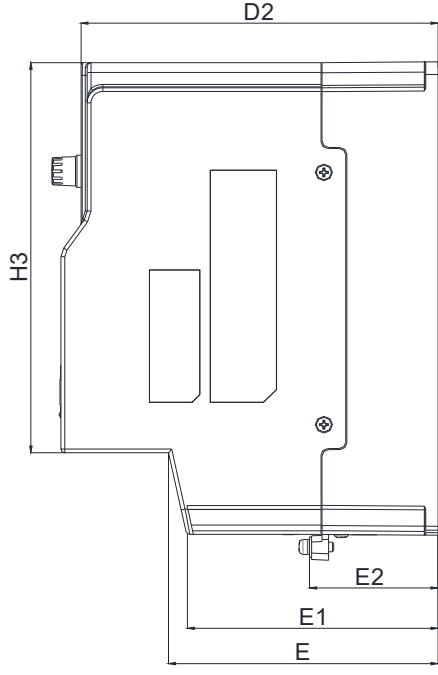
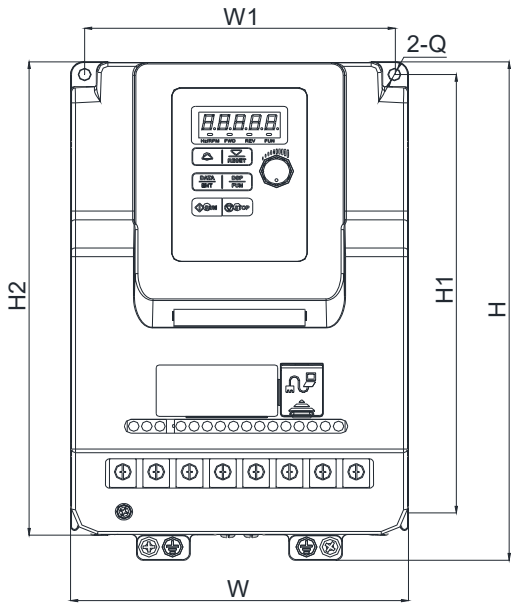

Model	dimension												
	W	W1	H	H1	H2	H3	D	D1	D2	E	E1	E2	Q
L510-205-SH3	129	118	197	177	188	154	148	143	136	102	96	48	4.5
L510-405-SH3													
L510-408-SH3													
L510-405-SH3F													
L510-408-SH3F													

Frame4

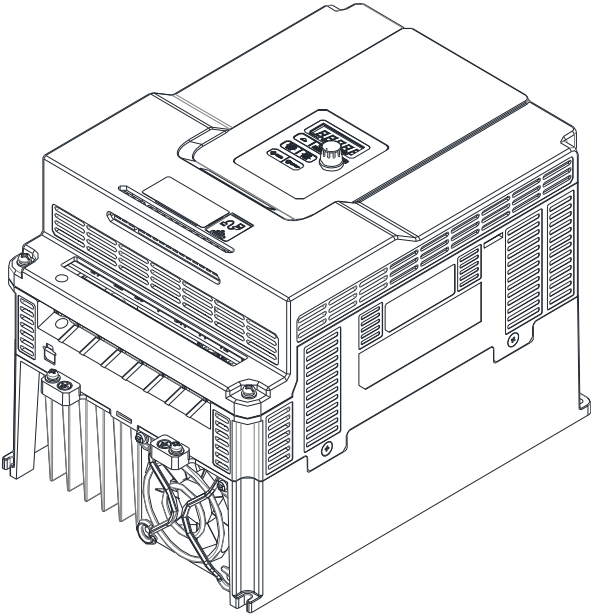
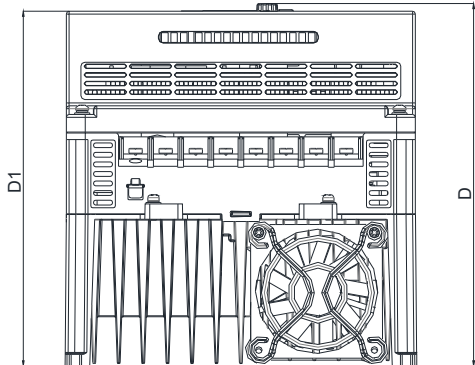
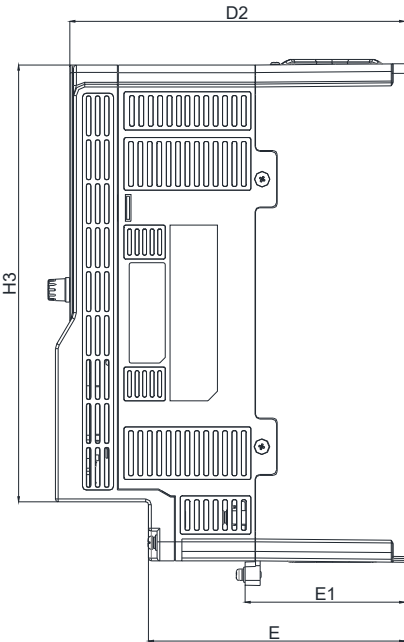
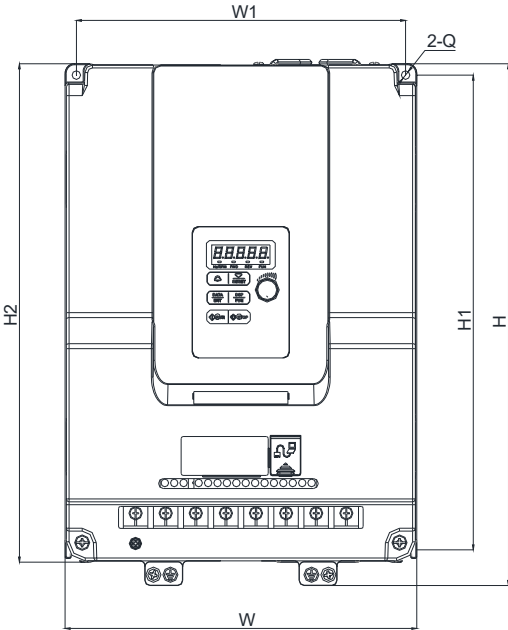

Model	dimension											
	W	W1	H	H1	H2	H3	D	D1	D2	E	E1	Q
L510-208-SH3	187	176	273	249	261	228	190	185	177	136	84	4.5
L510-210-SH3												
L510-410-SH3												
L510-415-SH3												
L510-410-SH3F												
L510-415-SH3F												

3.8 EMC Filter Disconnection

EMC filter may be disconnected:

Inverter drives with built-in EMC filter are not suitable for connection to certain type of supply systems, such as listed below; in these cases the RFI filter can be disabled.

In all such cases consult your local electrical standards requirements.

IT type supply systems (ungrounded) & certain supply systems for medical equipment.

For ungrounded supply systems, if the filter is not disconnected the supply system becomes connected to Earth through the Y capacitors on the filter circuit. This could result in danger and damage to the Drive.

Frame1&Frame2

Disconnection steps:

1. Remove EMC filter protection cover by screwdriver.
2. Remove EMC Filter link by pliers.

Note:- Disconnecting the EMC filter link will disables the filter function, please consult your local EMC standards requirement..

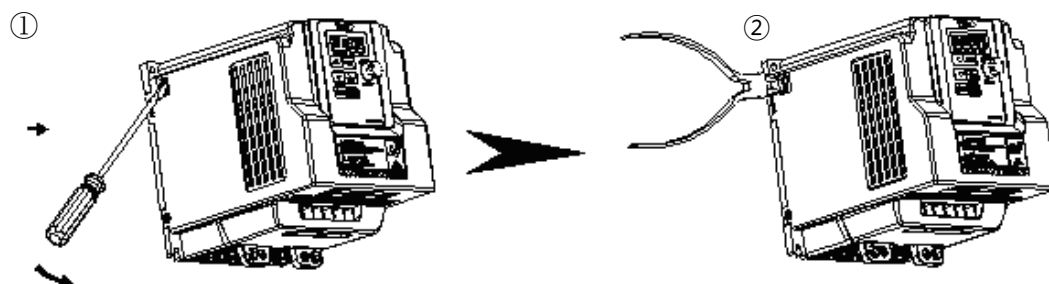

Frame 3/ Frame 4

Disconnection steps:

1. Loosen the screws for EMC filter by screwdriver
2. Remove EMC filter
3. Tighten the screw
4. Note:- Disconnecting the EMC filter link will disables the filter function, please consult your local EMC standards requirement..

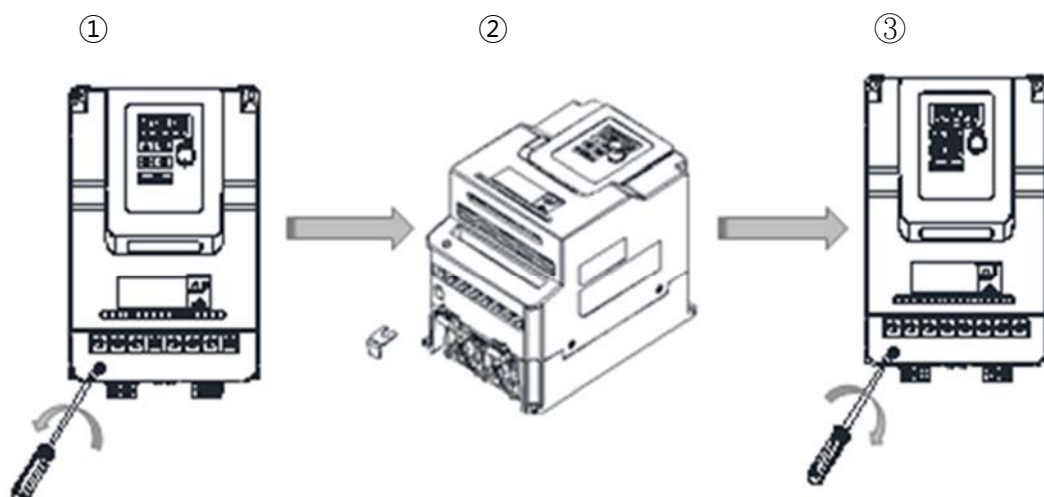

Chapter4 Software Index

4.1 Keypad Description

4.1.1 Operator Panel Functions



Type	Item	Function
Digital display & LEDs	Main digital displays	Frequency Display, Parameter, voltage, Current, Temperature, Fault messages.
	LED Status	Hz/RPM: ON when the frequency or line speed is displayed. OFF when the parameters are displayed. FWD: ON while the inverter is running forward. Flashes while stopped. REV: ON while the inverter is running reverse. Flashes while stopped. FUN: ON when the parameters are displayed.
Variable Resistor	FREQ SET	Used to set the frequency
Keys On Keypad	RUN	RUN: Run at the set frequency.
	STOP/RESET (Dual function keys)	STOP: Decelerate or Coast to Stop. RESET: Use to Reset alarms or resettable faults.
	▲	Increment parameter number and preset values.
	▼	Decrement parameter number and preset values.
	MODE	Switch between available displays
	</ENTER (Dual function keys, a short press for left shift function, a long press for ENTER function)	<“ Left Shift: Used while changing the parameters or parameter values ENTER: Used to display the preset value of parameters and for saving the changed parameter values.

4.1.2 Digital display Description

Alpha numerical display format

Digit	LED	Letter	LED	Letter	LED	Symbol	LED
0		A		n		-	
1		b		o		°	
2		C		P		_	
3		d		q		.	
4		E		r			
5		F		S			
6		G		t			
7		H		u			
8		J		v			
9		L		Y			

Digital display indication formats

Actual output frequency	Set frequency	
Digits are lit Continually	Preset digits flashing	Selected digit flashing

LED display examples

Display	Description
	In stop mode shows the set frequency In run mode shows the actual output frequency
	Selected Parameter
	Parameter Value
	Output Voltage
	Output Current in Amps
	DC Bus voltage
	Temperature
	PID feedback value
	Error display
	Analogue Current / Voltage ACID / AVI . Range (0~1000)

LED Status description

		LED Indicator light Status		
Frequency / line speed Indicator	Hz/RPM	On		
Menu mode indicator	Fun	On while not displaying frequency or line speed		
FWD indicator	FWD	On while running forward		Flashing while stopped in Forward mode.
REV indicator light	REV	On while running reverse		Flashing while stopped in Reverse mode

4.1.3 Digital display setup

On power up digital display screens will be as shown below.

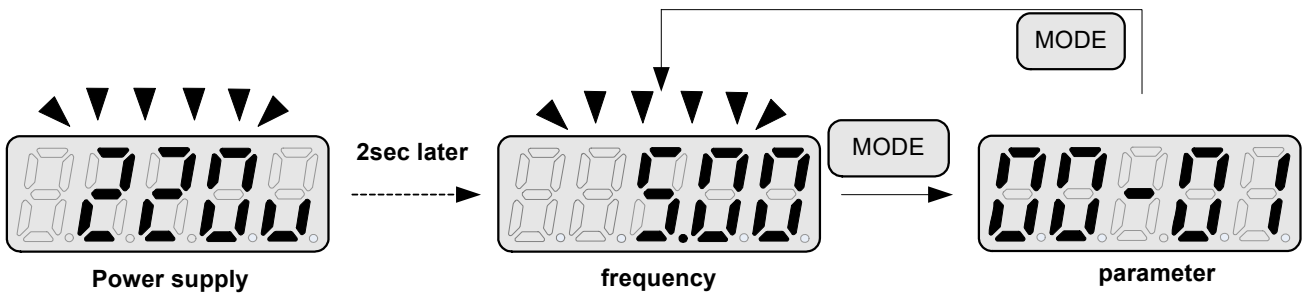

User selectable display formats:

12- 00	Display Mode								
	0 0 0 0 0								
	high Low								
	Each of the above 5 digits can be set to any of the selections below from 0 to 7								
Range	<table border="0"> <tr> <td>[0] :Disable display</td> <td>[1] :output Current</td> </tr> <tr> <td>[2] :output Voltage</td> <td>[3] :DC voltage</td> </tr> <tr> <td>[4] :Temperature</td> <td>[5] :PID feedback</td> </tr> <tr> <td>[6] :AVI</td> <td>[7] :ACI</td> </tr> </table>	[0] :Disable display	[1] :output Current	[2] :output Voltage	[3] :DC voltage	[4] :Temperature	[5] :PID feedback	[6] :AVI	[7] :ACI
[0] :Disable display	[1] :output Current								
[2] :output Voltage	[3] :DC voltage								
[4] :Temperature	[5] :PID feedback								
[6] :AVI	[7] :ACI								

The highest bit of 12-00 sets the power on the display, other bits set the selected display from range 0-7.as Listed above.

Example1: Set parameter 12- 00= [10000] to obtain display format shown below.

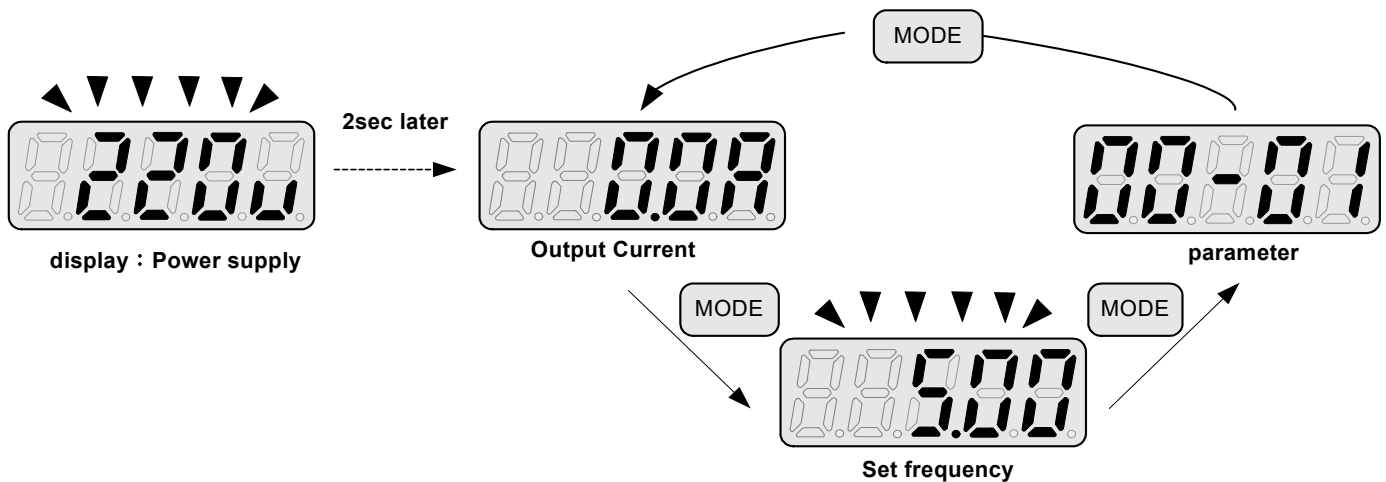

Example 2. Set parameter 2: 12- 00= [12345] to obtain the display format shown below.

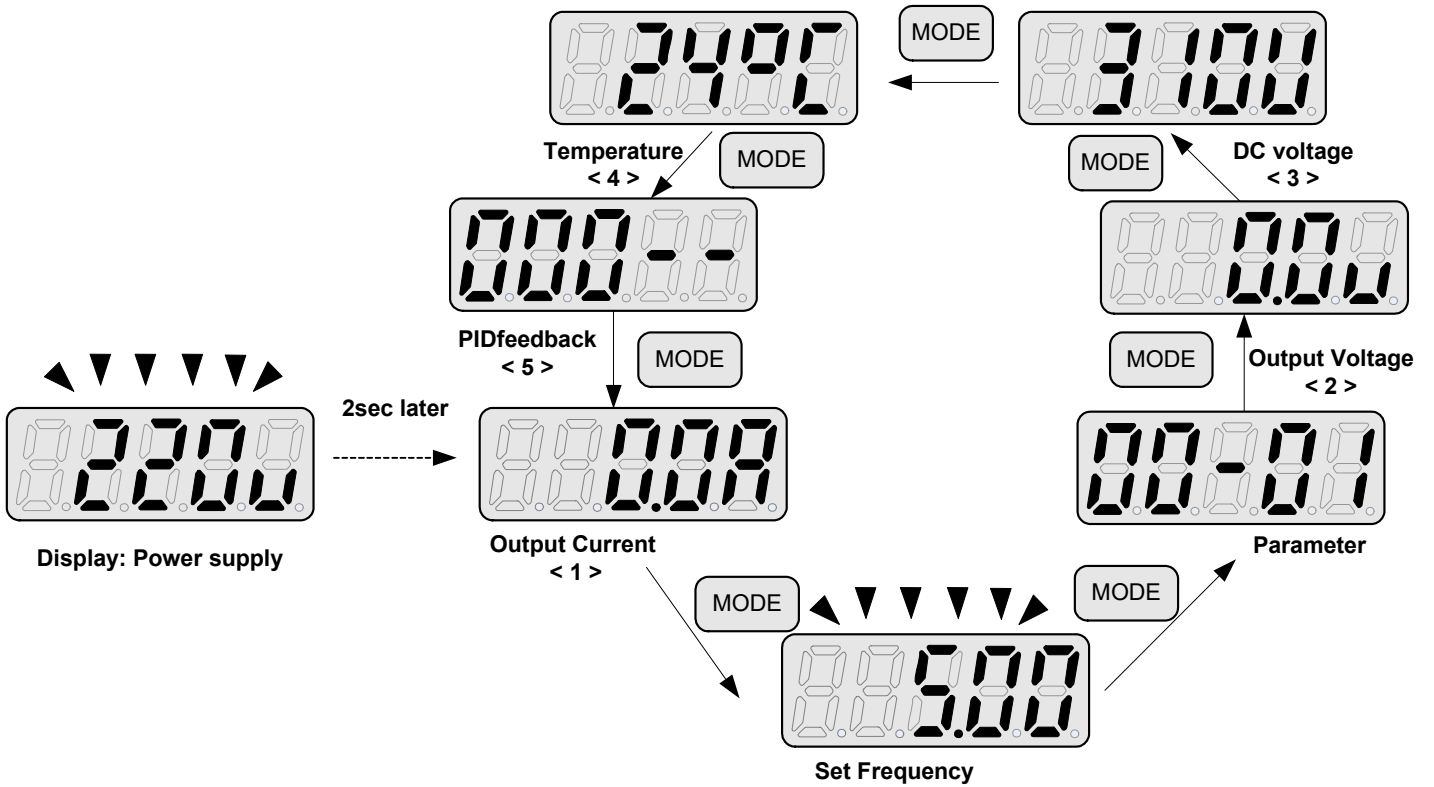

Increment/ Decrement key functions:

1. “▲”/“▼” :

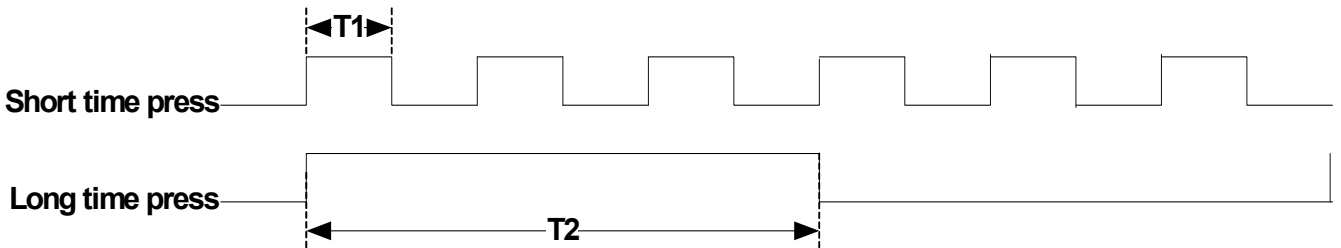

Quick pressing of these keys will Increment or Decrement the selected digit by one. Extended pressing will Increment or Decrement the selected digit continuously.

2. “</ENT” Key functions :

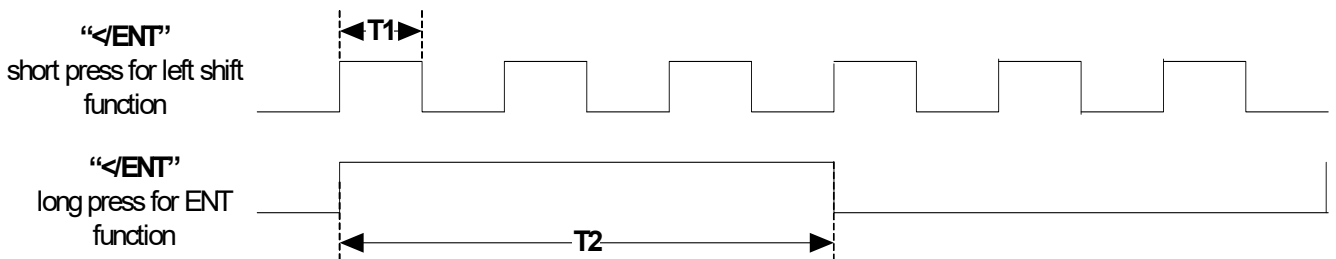

Quick pressing of this key will display the preset value of the parameter selected. Extended pressing of this key will save the altered value of the selected parameter.

4.1.4 Example of keypad operation

Example1: Modifying Parameters

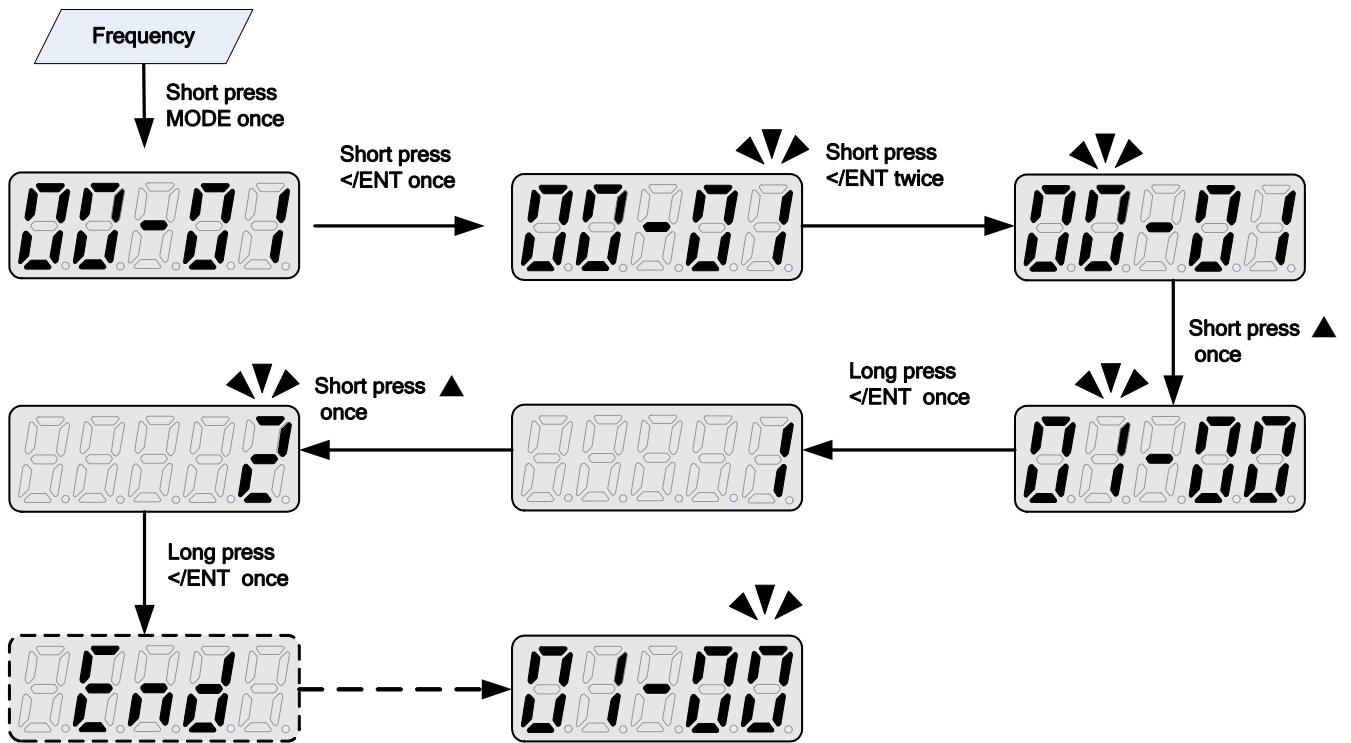

Example2: Modifying the frequency from keypad in run and stop modes.

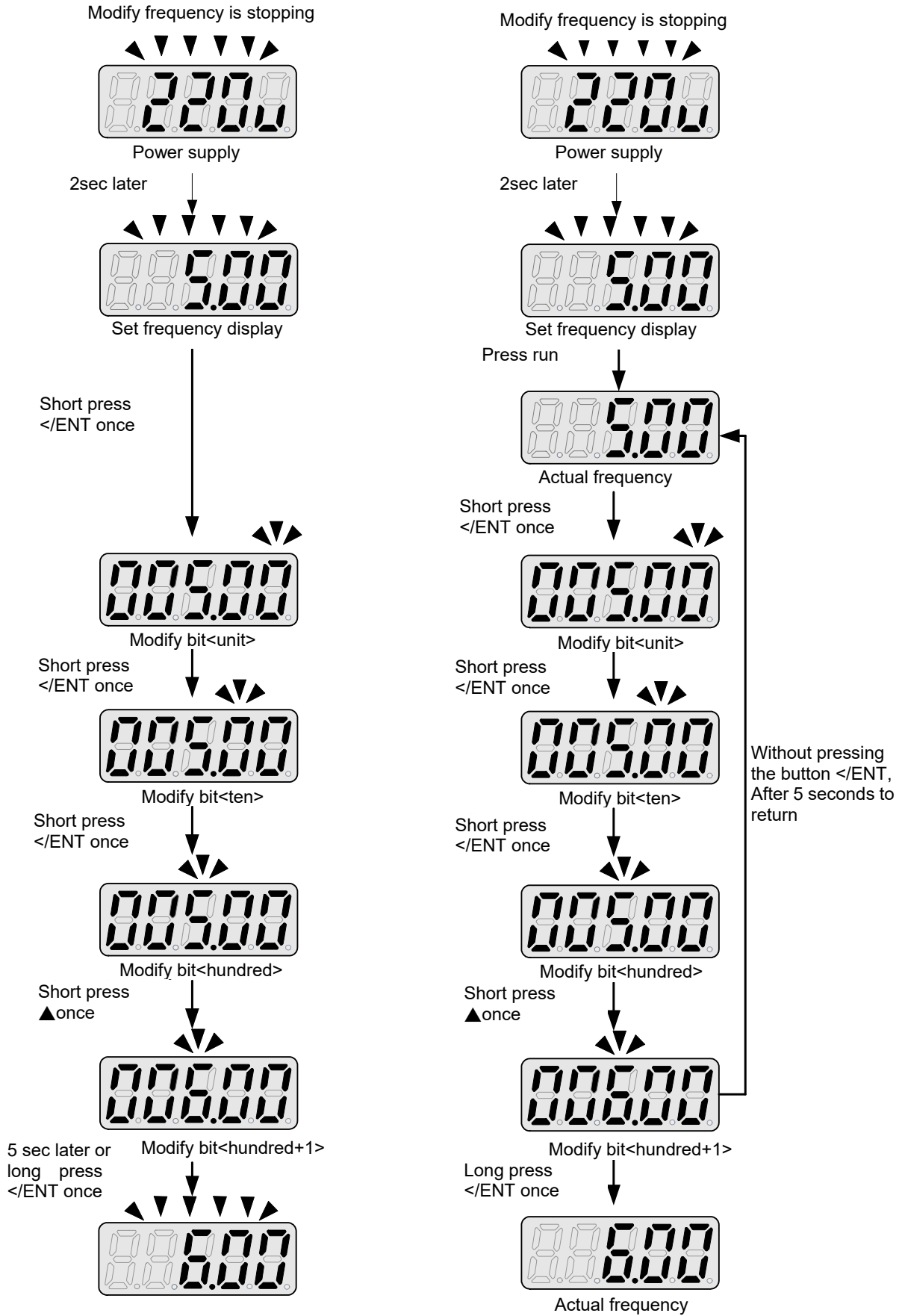

Note: frequency command setting will be limited to the range set by parameters for lower & upper frequency.

4.1.5 Operation Control

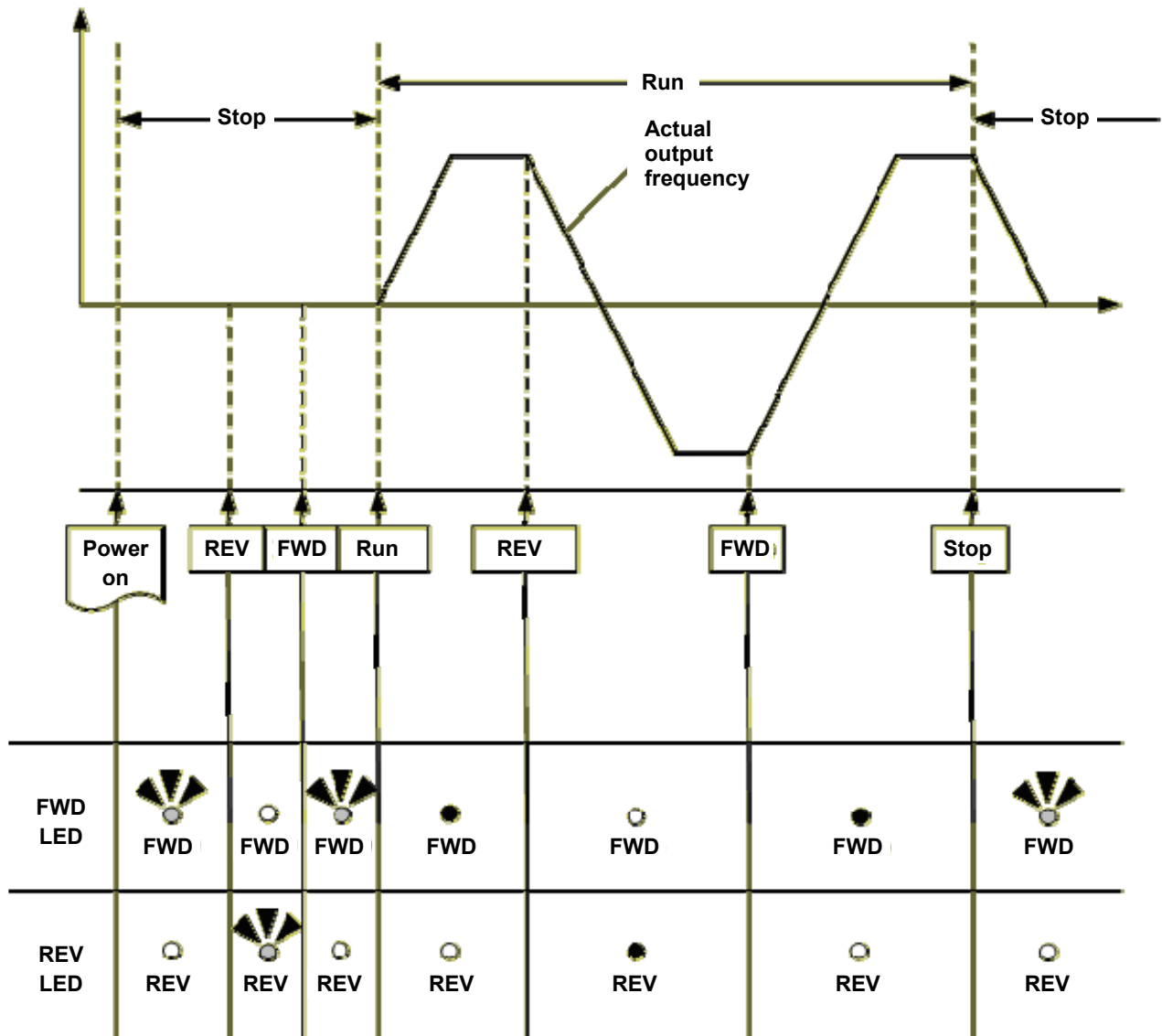

4.2 Programmable Parameter Groups

Parameter Group No.	Description
Group 00	Basic parameters
Group 01	V/F Pattern selections & setup
Group 02	Motor parameters
Group 03	Multi function digital Inputs/Outputs
Group 04	Analog signal inputs/ Analog output
Group 05	Preset Frequency Selections.
Group 06	Auto Run(Auto Sequencer) function
Group 07	Start/Stop command setup
Group 08	Drive and motor Protection
Group 09	Communication function setup
Group 10	PID function setup
Group 11	Performance control functions
Group 12	Digital Display & Monitor functions
Group 13	Inspection & Maintenance function
Group 14	PUMP Application Function

Parameter notes for Parameter Groups		
*1	Parameter can be adjusted during running mode	◇ : Revised in version 06
*2	Cannot be modified in communication mode	
*3	Does not change with factory reset	
*4	Read only	

Group 00- The basic parameters group					
No.	Description	Range	Factory Setting	Unit	Note
00-00	control mode	0:V/F mode 1:SLV mode	0	-	
00-01	Motor rotation	0:Forward 1:Reverse	0	-	*1
00-02	Main Run Source Selection	0:Keypad 1:External Run/Stop Control 2:Communication	1	-	
00-03	Alternative Run Source Selection	0:Keypad 1:External Run/Stop Control 2:Communication	0	-	
00-04	Operation modes for external terminals	0: Forward/Stop-Reverse/Stop 1: Run/Stop-Reverse/Forward 2: 3-Wire Control Mode-Run/Stop 3: 2-Wire self-holding Run/Stop	0	-	◇
00-05	Main Frequency Source Selection	0:Keypad 1:Potentiometer on Keypad 2:External AVI Analog Signal Input 3:External ACI Analog Signal Input 4:External Up/Down Frequency Control 5:Communication setting Frequency 6:PID output frequency	2	-	
00-06	Alternative Frequency Source Selection	0:Keypad 1:Potentiometer on Keypad 2:External AVI Analog Signal Input 3:External ACI Analog Signal Input 4:External Up/Down Frequency Control 5:Communication setting Frequency 6:PID output frequency.	0	-	
00-07	Main and Alternative Frequency Command modes	0: Main Or Alternative Frequency 1: Main frequency + Alternative Frequency	0	-	
00-08	Communication Frequency Command	0.00~599.00		Hz	*4
00-09	Frequency command Save mode (Communication mode)	0:Save the frequency before power down 1:Save the communication frequency	0	-	
00-10	Initial Frequency Selection (keypad mode)	0:by Current Frequency Command 1:by 0 Frequency Command 2:by 00-11	0	-	
00-11	Initial Frequency Keypad mode	0.00~599.00	50.00/60.00	Hz	
00-12	Frequency Upper Limit	0.01~599.00	50.00/60.00	Hz	
00-13	Frequency Lower Limit	0.00~598.99	0.00	Hz	
00-14	Acceleration Time 1	0.1~3600.0	10.0	s	*1
00-15	Deceleration Time 1	0.1~3600.0	10.0	s	*1
00-16	Acceleration Time 2	0.1~3600.0	10.0	s	*1
00-17	Deceleration Time 2	0.1~3600.0	10.0	s	*1
00-18	Jog Frequency	1.00~25.00	2.00	Hz	*1
00-19	Jog Acceleration Time	0.1~25.5	0.5	s	*1
00-20	Jog Deceleration Time	0.1~25.5	0.5	s	*1
00-21	Application Field Selection	0: Disable 3: Constant Pressure Application	0		◇

Group 01- V/F Pattern selection & Setup					
No.	Description	Range	Factory Setting	Unit	Note
01-00	Volts/Hz Patterns	1~7	1/4	-	
01-01	V/F Max voltage	200V:170.0~264.0 400V:323.0~528.0	Based on 13-08	Vac	
01-02	Max Frequency	0.2 ~ 599.00	50.00/60.00	Hz	
01-03	Max Frequency Voltage Ratio	0.0 ~ 100.0	100.0	%	
01-04	Mid Frequency 2	0.1 ~ 599.00	2.50/3.00	Hz	
01-05	Mid Frequency Voltage Ratio 2	0.0 ~ 100.0	7.5/6.8	%	◇
01-06	Mid Frequency 1	0.1 ~ 599.00	2.50/3.00	Hz	
01-07	Mid Frequency Voltage Ratio 1	0.0 ~ 100.0	7.5/6.8	%	◇
01-08	Min Frequency	0.1 ~ 599.00	1.30/1.50	Hz	
01-09	Min Frequency Voltage Ratio	0.0 ~ 100.0	4.5/3.4	%	◇
01-10	Volts/Hz Curve Modification (Torque Boost)	0 ~ 10.0	0.0	%	*1
01-11	V/F start Frequency	0.00~10.00	0.00	Hz	
01-12	No-load oscillation suppression gain	0.0~200.0	0	%	
01-13	Motor Hunting Prevention Coefficient	1~8192	800		
01-14	Motor Hunting Prevention Gain	0~100	0	%	◇
01-15	Motor Hunting Prevention Limit	0~100.0	5.0	%	
01-16	Auto-Torque Compensation Filter Coefficient	0.1~1000.0	0.1	ms	
01-17	Auto-torque Compensation Gain	0~100	0	%	
01-18	Auto-torque Compensation Frequency	1.30~5.00	2	Hz	

Group 02- Motor parameters

No.	Description	Range	Factory Setting	Unit	Note
02-00	Motor No Load Current	----	by motor nameplate	A	*4
02-01	Motor Rated Current (OL1)	----	by motor nameplate	A	*4
02-02	V/F Slip Compensation	0.0 ~ 100.0	0.0	%	*1
02-03	Motor Rated Speed	----	by motor nameplate	Rpm	*4
02-04	Motor Rated Voltage	----	by motor nameplate	Vac	*4
02-05	Motor Rated Power	0~22.0	by motor nameplate	kW	
02-06	Motor Rated Frequency	0~599.0	by motor nameplate		
02-07	Motor Auto Tuning	0: Disable 1: Static auto tuning	0		
02-08	Stator Resistor Gain	0~600	by series		
02-09	Rotor Resistor Gain	0~600	by series		
02-10	Reserved				
02-11	Reserved				
02-12	Reserved				
02-13	SLV Slip Compensation Gain	0~200	by series	%	
02-14	SLV Torque Compensation Gain	0~200	100	%	
02-15	Low Frequency Torque Gain	0~100	50	%	
02-16	SLV Without Load Slip Compensation Gain	0~200	by series	%	
02-17	SLV With Load Slip Compensation Gain	0~200	150	%	
02-18	SLV With Load Torque Compensation Gain	0~200	100	%	
02-19	SLV Slip Compensation Select	0: Slip Compensation 1 2: Slip Compensation 2	0		

Group 03- Multi function Digital Inputs/Outputs					
No.	Description	Range	Factory Setting	Unit	Note
03-00	Multifunction Input Term. S1	0: Forward/Stop Command 1: Reverse/Stop Command 2: Preset Speed setting bit 0 (5-02) 3: Preset Speed setting bit 1 (5-03) 4: Preset Speed setting bit 2 (5-05)	0	-	
03-01	Multifunction Input Term. S2	6: Jog Forward Command 7: Jog Reverse Command 8: Up Command 9: Down Command	1	-	
03-02	Multifunction Input Term. S3	10: Acc/Dec 2 11: Acc/Dec Disabled 12: Main/Alternative Run Command select 13: Main/Alternative Frequency Command select	2	-	
03-03	Multifunction Input Term. S4	14: Rapid Stop (Decel to stop) 15: Base Block 16: Disable PID Function 17: Reset	3	-	
03-04	Multifunction Input Term. S5	18: Auto Run Mode enable 19: Forced Frequency Run(pump model only) 20: Switch to Constant Pressure 2(pump model only)	17	-	
03-05	Reserved				
03-06	Up/Down frequency band	0.00~5.00	0.00	Hz	
03-07	Up/Down Frequency modes	0: Preset frequency is held as the inverter stops, and UP/Down function is disabled. 1: Preset frequency is reset to 0 Hz as the inverter stops. 2: Preset frequency is held as the inverter stops, and the UP/Down is available.	0	-	
03-08	S1~S5 scan confirmation	1~200. Number of Scan cycles	10	2ms	
03-09	S1~ S5 switch type select	xxxx0:S1 NO xxx1:S1 NC xxx0x:S2 NO xxx1x:S2 NC xx0xx:S3 NO xx1xx:S3 NC x0xxx:S4 NO x1xxx:S4 NC 0xxxx:S5 NO 1xxxx:S5 NC	00000	-	
03-10	Reserved				
03-11	Output Relay(RY1)	0: Run 1: Fault 2: Setting Frequency Reached 3: Frequency Reached (3-13±3-14) 4: Output Frequency Detection1(> 3-13) 5: Output Frequency Detection2(< 3-13) 6: Auto-Restart 7: Momentary AC Power Loss 8: Rapid Stop 9: Base Block 10: Motor Overload Protection(OL1) 11: Drive Overload Protection(OL2) 12: Reserved 13: Output Current Reached 14: Brake Control 15: PID feedback disconnection detection 16: High Pressure Detection 17: Low Pressure Detection 18: Pressure Loss Detection	1	-	

No.	Description	Range	Factory Setting	Unit	Note	
03-13	Output frequency detection level (Hz)	0.00~599.00	0.00	Hz	*1	
03-14	Frequency Detection band	0.00~30.00	2.00	Hz	*1	
03-15	Output Current Detection Level	0.1~999.9	0.1	A		
03-16	Output Current Detection Period	0.1~10.0	0.1	s		
03-17	External Brake Release level	0.00~20.00	0.00	Hz		
03-18	External Brake Engage Level	0.00~20.00	0.00	Hz		
03-19	Relay Output function type	0:A (Normally open) 1:B (Normally close)	0	-		
03-20	Braking Transistor On Level	100/200V: 240.0~400.0V 400V: 500.0~800.0V	100/220/230V:	380	VDC	◇
			380/400V:	690		
			415/460V:	780		
03-21	Brake Transistor Off Level	100/200V: 240.0~400.0V 400V: 500.0~800.0V	100/220/230V:	360	VDC	◇
			380/400V:	650		
			415/460V:	740		

※ “NO” indicates normally open, “NC” indicates normally closed.

Group 04- Analog signal inputs/ Analogue output functions

No.	Description	Range	Factory Setting	Unit	Note
04-00	AVI/ACI analog Input signal type select	0 : AVI ACI 0~10V 0~20mA	0	-	
		1 : 0~10V 4~20mA			
		2 : 2~10V 0~20mA			
		3 : 2~10V 4~20mA			
04-01	AVI Signal Verification Scan rate	1~200	50	2ms	
04-02	AVI Gain	0~1000	100	%	*1
04-03	AVI Bias	0~100	0	%	*1
04-04	AVI Bias Selection	0: Positive 1: Negative	0	-	*1
04-05	AVI Slope	0: Positive 1: Negative	0	-	*1
04-06	ACI Signal Verification Scan rate	1~200	50	2ms	
04-07	ACI Gain	0~1000	100	%	*1
04-08	ACI Bias	0~100	0	%	*1
04-09	ACI Bias Selection	0: Positive 1: Negative	0	-	*1
04-10	ACI Slope	0: Positive 1: Negative	0	-	*1
04-11	Analog Output mode (AO)	0: Output Frequency 1: Frequency Command 2: Output Voltage 3: DC Bus Voltage 4: Motor Current	0	-	*1
04-12	Analog Output AO Gain (%)	0~1000	100	%	*1
04-13	Analog Output AO Bias (%)	0~100	0	%	*1
04-14	AO Bias Selection	0: Positive 1: Negative	0	-	*1
04-15	AO Slope	0: Positive 1: Negative	0	-	*1
04-16	Potentiometer Gain on Keypad	0~1000	100	%	*1
04-17	Potentiometer Bias on Keypad	0~100	0	%	*1
04-18	Potentiometer Bias Selection on Keypad	0: Positive 1: Negative	0	-	*1
04-19	Potentiometer Slop on Keypad	0: Positive 1: Negative	0	-	*1

Group 05- Preset Frequency Selections.					
No.	Description	Range	Factory Setting	Unit	Note
05-00	Preset Speed Control mode Selection	0: Common Accel/ Decel 1 or 2 apply to all speeds 1: Individual Accel/ Decel 0-7 apply to the selected preset speeds (Acc0/Dec0~ Acc7/Dec7)	0	-	
05-01	Preset Speed 0 (Keypad Freq.)	0.00 ~ 599.00	5.00	Hz	*1
05-02	Preset Speed1	0.00 ~ 599.00	5.00	Hz	*1
05-03	Preset Speed2	0.00 ~ 599.00	10.00	Hz	*1
05-04	Preset Speed3	0.00 ~ 599.00	20.00	Hz	*1
05-05	Preset Speed4	0.00 ~ 599.00	30.00	Hz	*1
05-06	Preset Speed5	0.00 ~ 599.00	40.00	Hz	*1
05-07	Preset Speed6	0.00 ~ 599.00	50.00	Hz	*1
05-08	Preset Speed7	0.00 ~ 599.00	50.00	Hz	*1
05-09 ~ 05-16	Reserved				
05-17	Preset Speed0-Acctime	0.1 ~ 3600.0	10.0	s	*1
05-18	Preset Speed0-Dectime	0.1 ~ 3600.0	10.0	s	*1
05-19	Preset Speed1-Acctime	0.1 ~ 3600.0	10.0	s	*1
05-20	Preset Speed1-Dectime	0.1 ~ 3600.0	10.0	s	*1
05-21	Preset Speed2-Acctime	0.1 ~ 3600.0	10.0	s	*1
05-22	Preset Speed2-Dectime	0.1 ~ 3600.0	10.0	s	*1
05-23	Preset Speed3-Acctime	0.1 ~ 3600.0	10.0	s	*1
05-24	Preset Speed3-Dectime	0.1 ~ 3600.0	10.0	s	*1
05-25	Preset Speed4-Acctime	0.1 ~ 3600.0	10.0	s	*1
05-26	Preset Speed4-Dectime	0.1 ~ 3600.0	10.0	s	*1
05-27	Preset Speed5-Acctime	0.1 ~ 3600.0	10.0	s	*1
05-28	Preset Speed5-Dectime	0.1 ~ 3600.0	10.0	s	*1
05-29	Preset Speed6-Acctime	0.1 ~ 3600.0	10.0	s	*1
05-30	Preset Speed6-Dectime	0.1 ~ 3600.0	10.0	s	*1
05-31	Preset Speed7-Acctime	0.1 ~ 3600.0	10.0	s	*1
05-32	Preset Speed7-Dectime	0.1 ~ 3600.0	10.0	s	*1

Group 06- Auto Run(Auto Sequencer) function

No.	Description	Range	Factory Setting	Unit	Note
06-00	Auto Run (sequencer) mode selection	0: Disabled. 1: Single cycle. (Continues to run from the Unfinished step if restarted). 2: Periodic cycle. (Continues to run from the unfinished step if restarted). 3: Single cycle, then holds the speed Of final step to run. (Continues to run from the unfinished step if restarted). 4: Single cycle. (Starts a new cycle if restarted). 5: Periodic cycle. (Starts a new cycle if restarted). 6: Single cycle, then hold the speed of final step to run (Starts a new cycle if restarted).	0	-	
The frequency of the Auto _ Run Mode frequency command 0 is set by parameter 05-01					
06-01	Auto _ Run Mode frequency command 1	0.00~599.00	0.00	Hz	*1
06-02	Auto _ Run Mode frequency command 2	0.00~599.00	0.00	Hz	*1
06-03	Auto _ Run Mode frequency command 3	0.00~599.00	0.00	Hz	*1
06-04	Auto _ Run Mode frequency command 4	0.00~599.00	0.00	Hz	*1
06-05	Auto _ Run Mode frequency command 5	0.00~599.00	0.00	Hz	*1
06-06	Auto _ Run Mode frequency command 6	0.00~599.00	0.00	Hz	*1
06-07	Auto _ Run Mode frequency command 7	0.00~599.00	0.00	Hz	*1
06-16	Auto _ Run Mode running time setting 0	0.0 ~ 3600.0	0.0	s	*1
06-17	Auto _ Run Mode running time setting 1	0.0 ~ 3600.0	0.0	s	*1
06-18	Auto _ Run Mode running time setting 2	0.0 ~ 3600.0	0.0	s	*1
06-19	Auto _ Run Mode running time setting 3	0.0 ~ 3600.0	0.0	s	*1
06-20	Auto _ Run Mode running time setting 4	0.0 ~ 3600.0	0.0	s	*1
06-21	Auto _ Run Mode running time setting 5	0.0 ~ 3600.0	0.0	s	*1
06-22	Auto _ Run Mode running time setting 6	0.0 ~ 3600.0	0.0	s	*1
06-23	Auto _ Run Mode running time setting 7	0.0 ~ 3600.0	0.0	s	*1
06-32	Auto _ Run Mode running direction 0	0: Stop 1: Forward 2: Reverse	0	-	
06-33	Auto _ Run Mode running direction 1	0: Stop 1: Forward 2: Reverse	0	-	
06-34	Auto _ Run Mode running direction 2	0: Stop 1: Forward 2: Reverse	0	-	
06-35	Auto _ Run Mode running direction 3	0: Stop 1: Forward 2: Reverse	0	-	

Group 06- Auto Run(Auto Sequencer) function

No.	Description	Range	Factory Setting	Unit	Note
06-36	Auto_ Run Mode running direction 4	0: Stop 1: Forward 2: Reverse	0	-	
06-37	Auto_ Run Mode running direction 5	0: Stop 1: Forward 2: Reverse	0	-	
06-38	Auto_ Run Mode running direction 6	0: Stop 1: Forward 2: Reverse	0	-	
06-39	Auto_ Run Mode running direction 7	0: Stop 1: Forward 2: Reverse	0	-	

Group 07- Start/Stop command setup					
No.	Description	Range	Factory Setting	Unit	Note
07-00	Momentary Power Loss and Restart	0: Momentary Power Loss and Restart disable 1: Momentary power loss and restart enable	0	s	
07-01	Auto Restart Delay Time	0.0~6000.0	0.0	s	
07-02	Number of Auto Restart Attempts	0~10	0	-	
07-03	Reset Mode Setting	0: Enable Reset Only when Run Command is Off 1: Enable Reset when Run Command is On or Off	0	-	
07-04	Direct Running After Power Up	0: Enable Direct run on power up 1: Disable Direct run on power up	1	-	
07-05	Delay-ON Timer	1.0~300.0	1.0	s	
07-06	DC Injection Brake Start Frequency (Hz) In Stop mode	0.10 ~ 10.00	1.5	Hz	
07-07	DC Injection Brake Level (%) In stop mode	0 ~ 20 (Frame1/2). Based on the 20% of maximum output voltage	5	%	
		0 ~ 100 (Frame3/4) based on the rated current	50		
07-08	DC Injection Brake Time (Seconds) In stop mode	0.0 ~ 25.5	0.5	s	
07-09	Stopping Method	0: Deceleration to stop 1: Coast to stop	0		
07-10	DC Braking Level at Start	0 ~ 20 (Frame1/2). Based on the 20% of maximum output voltage	0	%	
		0 ~ 100 (Frame3/4) based on the rated current	50	%	
07-11	DC Braking Time at Start	0.0~25.5	0.0	s	
07-12	Run Command Retention	0: Run command retention during power loss 1: Run command not retained during power loss	1		

Note: Set 14-00=0, 07-12 will be set to 1 automatically.
Set 14-00=1, 07-12 will be set to 0 automatically.

Group 08- Drive & Motor Protection functions

No.	Description	Range	Factory Setting	Unit	Note
08-00	Trip Prevention Selection	xxxx0: Enable Trip Prevention During Acceleration xxxx1: Disable Trip Prevention During Acceleration xxx0x: Enable Trip Prevention During Deceleration xxx1x: Disable Trip Prevention During Deceleration xx0xx: Enable Trip Prevention in Run Mode xx1xx: Disable Trip Prevention in Run Mode x0xxx: Enable over voltage Prevention in Run Mode x1xxx: Disable over voltage Prevention in Run Mode	00000	-	
08-01	Trip Prevention Level During Acceleration (%)	50 ~ 200	by series	Inverter Rated Current 100%	
08-02	Trip Prevention Level During Deceleration (%)	50 ~ 200	by series		
08-03	Trip Prevention Level In Run Mode (%)	50 ~ 200	by series		
08-04	over voltage Prevention Level in Run Mode	200V: 350.0~390.0 400V: 700.0~780.0	380.0/760.0	VDC	*1
08-05	Electronic Motor Overload Protection Operation Mode	xxxx0: Disable Electronic Motor Overload Protection xxxx1: Enable Electronic Motor Overload Protection xxx0x: Motor Overload Cold Start xxx1x: Motor Overload Hot Start xx0xx: Standard Motor xx1xx: Inverter Duty Motor	00001	-	
08-06	Operation After Overload Protection is Activated	0: Coast-to-Stop After Overload Protection is Activated 1: Drive Will Not Trip when Overload Protection is Activated (OL1)	0	-	
08-07	Over heat Protection (cooling fan control)	0: Auto (Depends on temp.) 1: Operate while in RUN mode 2: Always Run 3: Disabled	1	-	
08-08	AVR Function (Auto Voltage Regulation)	0: AVR function enable 1: AVR function Disable 2: AVR function disable for stop 3: AVR function disable for deceleration 4: AVR function disable for stop and deceleration. 5: When VDC>(360V/740V), AVR function disable for stop and deceleration.	4	-	
08-09	Input phase lost protection	0: Disabled 1: Enabled	0	-	

Group 08- Drive & Motor Protection functions

No.	Description	Range	Factory Setting	Unit	Note
08-10	PTC Overheat Function	0: Disable 1: Decelerate to stop 2: Coast to stop 3: Continue running, when warning level is reached. Coast to stop, when protection level is reached.	0		
08-11	PTC Signal Smoothing Time	0.01~10.00	0.2	Sec	
08-12	PTC Detection Time Delay	1~300	60	Sec	
08-13	PTC Protection Level	0.1~10.0	0.7	V	
08-14	PTC Detection Level Reset	0.1~10.0	0.3	V	
08-15	PTC Warning Level	0.1~10.0	0.5	V	
08-16	Fan Control Temperature Level	10.0~50.0	50.0	°C	
08-17	Over current protection level	0.0 ~ 60.0	0.0	A	
08-18	Over current protection time	0.0 ~ 1500.0	1.0	s	
08-19	Motor Overload Protection Level	0: Motor Overload Protection Level 0 1: Motor Overload Protection Level 1 2: Motor Overload Protection Level 2	0		

Group 09- Communication function setup					
No.	Description	Range	Factory Setting	Unit	Note
09-00	Assigned Communication Station Number	1 ~ 32	1	-	*2*3
09-01	Communication Mode Select	0: Modbus RTU code 1: Modbus ASCII code 2: BACnet	0	-	*2*3
09-02	Baud Rate Setting (bps)	0: 4800 1: 9600 2: 19200 3: 38400 4: Remote Keypad Control is enabled	2	bps	*2*3 ◇
09-03	Stop Bit Selection	0: 1 Stop Bit 1: 2 Stop Bits	0	-	*2*3
09-04	Parity Selection	0: Without Parity 1: With Even Parity 2: With Odd Parity	0	-	*2*3
09-05	Data Format Selection	0: 8-Bits Data 1: 7-Bits Data	0	-	*2*3
09-06	Communication time-out detection time	0.0 ~ 25.5	0.0	s	
09-07	Communication time-out operation selection	0: Deceleration to stop (set by 00-15) 1: Coast to stop 2: Deceleration to stop (set by 00-17) 3: continue operating	0	-	
09-08	Error 6 verification time.	0 ~ 20	3		
09-09	Drive Transmit delay Time (ms)	5 ~ 65	5	2ms	
09-10	BACnet stations	1~254	1		*2*3

Group10- PID function Setup

No.	Description	Range	Factory Setting	Unit	Note
10-00	PID target value selection (when 00-05\00-06=6 ,this function is enabled)	0: Potentiometer on Keypad 1: Analog Signal Input. (AVI) 2: Analog Signal Input. (ACI) 3: Frequency set by communication 4: 10-02 given 5: Preset frequency	1	-	*1
10-01	PID feedback value selection	0: Potentiometer on Keypad 1: Analog Signal Input. (AVI) 2: Analog Signal Input. (ACI) 3: Communication Setting Frequency	2	-	*1
10-02	PID Target (keypad input)	0.0~100.0	50.0	%	*1
10-03	PID Mode Selection	0: Disabled. 1: Deviation D Control. FWD Characteristic. 2: Feedback D Control. FWD Characteristic 3: Deviation D Control. Reverse Characteristic. 4: Feedback D Control. Reverse Characteristic 5: Frequency Command + Deviation D Control. FWD Characteristic 6: Frequency Command + Feedback D Control FWD Characteristic. 7: Frequency Command + Deviation D Control Reverse Characteristic. 8: Frequency Command + Feedback D Control Reverse Characteristic	0	-	
10-04	Feedback Gain Coefficient	0.00 ~ 10.00	1.00	%	*1
10-05	Proportional Gain	0.0 ~ 10.0	3.0	%	*1
10-06	Integral Time	0.0 ~ 100.0	0.5	s	*1
10-07	Derivative Time	0.00 ~ 10.00	0.00	s	*1
10-08	PID Offset	0: Positive 1: Negative	0	-	*1
10-09	PID Offset Adjust	0 ~ 109	0	%	*1
10-10	PID Output Lag Filter Time	0.0 ~ 2.5	0.0	s	*1
10-11	Feedback Loss Detection Mode	0: Disabled 1: Drive keeps running after feedback loss 2: Drive stops after feedback loss	0	-	
10-12	Feedback Loss Detection Level	0 ~ 100	0	%	
10-13	Feedback Loss Detection Delay Time	0.0 ~25.5	1.0	s	
10-14	Integration Limit Value	0 ~ 109	100	%	*1
10-15	Integral Value Resets to Zero when Feedback Signal Equals the Target Value	0: Disabled 1: 1 Second 30: 30 Seconds (0 ~ 30)	0	-	
10-16	Allowable Integration Error. Margin (units)(1unit = 1/8192)	0 ~ 100	0	-	
10-17	PID Sleep Frequency Level	0.00~599.00	0.00	Hz	
10-18	PID Sleep Function Delay Time	0.0 ~25.5	0.0	s	
10-19	PID Wake up frequency Level	0.00 ~ 599.00	0.00	Hz	
10-20	PID Wake up function Delay Time	0.0 ~ 25.5	0.0	s	
10-21	Max PID Feedback Setting	0 ~999	100	-	*1
10-22	Min PID Feedback Setting	0 ~999	0	-	*1

Group11- Performance Control functions

No.	Description	Range	Factory Setting	unit	Note
11-00	Reverse operation control	0: Reverse command is valid 1: Reverse command is invalid	0	-	
11-01	Carrier Frequency (kHz)	1~16	5	KHz	
11-02	Carrier mode Selection	0: Mode0, 3phase PWM modulation 1: Mode1, 2phase PWM modulation 2: Mode2, random PWM modulation	1	-	
11-03	Carrier Frequency Reduction by temperature rise	0: Disabled 1: Enabled	0	-	
11-04	S-Curve Acc 1	0.0~4.0	0.00	s	
11-05	S-Curve Acc 2	0.0~4.0	0.00	s	
11-06	S-Curve Dec 3	0.0~4.0	0.00	s	
11-07	S-Curve Dec 4	0.0~4.0	0.00	s	
11-08	Skip Frequency 1	0.00~599.00	0.00	Hz	*1
11-09	Skip Frequency 2	0.00~599.00	0.00	Hz	*1
11-10	Skip Frequency 3	0.00~599.00	0.00	Hz	*1
11-11	Skip Frequency Bandwidth (±)	0.00~30.00	0.00	Hz	*1
11-12	Reserved				
11-13	Regeneration Prevention Function	0: Disable 1: Enable 2: Enable (during constant speed only)	0	-	
11-14	Regeneration Prevention Voltage Level	200v: 300.0~400.0 400v: 600.0~800.0	380/760	V	
11-15	Regeneration Prevention Frequency Limit	0.00~15.00	3.00	Hz	
11-16	Regeneration Prevention Voltage Gain	0~200	100	%	
11-17	Regeneration Prevention Frequency Gain	0~200	100	%	
11-18	Speed loop proportion gain	0~65535	10000		
11-19	Speed loop integration gain	0~65535	800		
11-20	Speed loop differential gain	0~65535	0		
11-21	Stop Key Selection	0: Enable Stop Key when Run Command not from Keypad 1: Disable Stop Key when Run Command not from Keypad	0		

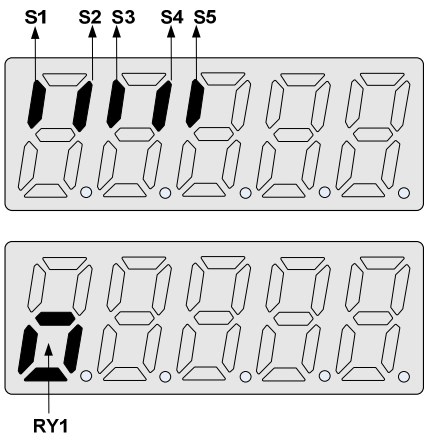
Group12 Digital Display & Monitor functions					
No.	Description	Range	Factory Setting	Unit	Note
12-00	Extended Display Mode	00000 ~77777. Each digit can be set to 0 to 7 0: Default display (frequency & parameters) 1:Output Current 2:Output Voltage 3:DC voltage 4:Temperature of Heat sink 5:PID feedback 6:Analog Signal Input. (AVI) 7:Analog Signal Input. (ACI)	00321	-	*1
12-01	PID Feedback Display format	0: Integer (xxx) 1: One decimal Place (xx.x) 2: Two Decimal Places (x.xx)	0	-	*1
12-02	PID Feedback Display Unit Setting	0: xxx-- 1: xxxpb (pressure) 2: xxxfl (flow)	0	-	*1
12-03	Custom Units (Line Speed) Value	0~65535	1500/1800	RPM	*1
12-04	Custom Units (Line Speed) Display Mode	0:Drive Output Frequency is Displayed 1:Line Speed, Integer.(xxxxx) 2:Line Speed, One Decimal Place (xxxx.x) 3:Line Speed, Two Decimal Places (xxx.xx) 4:Line Speed, Three Decimal Places (xx.xxx)	0	-	*1
12-05	Inputs and output Logic status display (S1 to S5) & RY1		----	-	*4
12-06	Output Power	----	0.0	kW	
12-07	Motor Current Percentage	----	0	%	

Group 13 Inspection & Maintenance functions

No.	Description	Range	Factory Setting	unit	Note
13-00	Drive Horsepower Code	----	-	-	*3
13-01	Software Version	----	-	-	*3*4
13-02	Fault Log (Last 3 Faults)	----	-	-	*3*4
13-03	Accumulated Operation Time1 1	0~23	-	hour	*3
13-04	Accumulated Operation Time1 2	0~65535	----	day	*3
13-05	Accumulated Operation Time Mode	0: Time Under Power 1: Run Mode Time Only	0	-	*3
13-06	Parameter Lock	0: Enable all Functions 1: Preset speeds 05-01~05-08 cannot be changed 2: All Functions cannot be changed except for Preset speeds 05-01~05-08 3: Disable All Function 4: Parameters 00-00 cannot be modified, cannot be restored to factory settings, other parameters can be changed	0	-	
13-07	Parameter Lock Code	00000~65535	00000	-	
13-08	Restore Factory Settings	1150: Initialization (50Hz,220V/380V) 1160: Initialization (60Hz,220V/380V) 1250: Initialization (50Hz,230V/400V) 1260: Initialization (60Hz,230V/460V) 1350: Initialization (50Hz,220V/415V) 1360: Initialization (60Hz,230V/400V)	1250/1360 (Note)	-	

Notes:

For built-in EMC filter models, the default setting of 13-08 is “1250”.

For without built-in EMC filter models, the default setting of 13-08 is “1360”

Group 14 PUMP Application Function

No.	Description	Range	Factory Setting	unit	Note
14-00	Function Selection	0: Disable 1: PUMP	0	-	
14-01	Setting of Single & Multiple Pumps and Master & Slave Machines	0: Single Pump 1: Multiple pumps-Master 2: Multiple pumps-Slave 1 3: Multiple pumps-Slave 2 4: Multiple pumps-Slave 3	0	-	
14-02	Operation Pressure Setting	0.1~(the value of 14-03)	4.00	PSI	
14-03	Maximum Pressure Setting of Pressure Transmitter	0.10 ~ 650.00	10.00	PSI	
14-04	Pump Pressure Command Source	0 : Set by 14-02 1 : Set by AI	0	-	
14-05	Display Mode Selection	0: Display of Target and Pressure Feedback (14-03<99) 1: Target Pressure Only 2: Feedback Pressure Only	0	-	
14-06	Proportion Gain(P)	0.00~10.00	3.00	-	
14-07	Integral Time(I)	0.0~100.0	0.5	sec	
14-08	Differential Time(D)	0.00~10.00	0.00	sec	
14-09	Tolerance Range of Constant Pressure	When 14-20=0, range is 0.00~650.00 When 14-20=1, range is 0~100	5	PSI/%	
14-10	Sleep Frequency of Constant Pressure	0.00~599.00	30.00	Hz	
14-11	Sleep Time of Constant Pressure	0.0~255.5	0.0	sec	
14-12	Maximum Pressure Limit	When 14-20=0, range is 0.00~650.00 When 14-20=1, range is 0~100	50	PSI/%	
14-13	Warning Time of High Pressure	0.0~600.0	10	sec	
14-14	Stop Time of High Pressure	0.0~600.0	20	sec	
14-15	Minimum Pressure Limit	When 14-20=0, range is 0.00~650.00 When 14-20=1, range is 0~100	5	PSI/%	
14-16	Warning Time of Low Pressure	0.0~600.0	0.0	sec	
14-17	Fault Stop Time of Low Pressure	0.0~600.0	0.0	sec	
14-18	Time of Loss Pressure Detection	0.0~600.0	0.0	sec	
14-19	Proportion of Loss Pressure Detection	0~100	0	%	
14-20	Switching of Pressure and Percentage	0: Pressure 1: Percentage	1	-	
14-22	Slave Trip Frequency	0.00 ~ 599.00	45.00	Hz	
14-23	Direction of Water Pressure Detection	0: Upward Detection 1: Downward Detection	1	-	

Group 14 PUMP Application Function

No.	Description	Range	Factory Setting	unit	Note
14-24	Range of Water Pressure Detection	When 14-20=0, range is 0.00~650.00 When 14-20=1, range is 0~100	1	PSI/%	
14-25	Period of Water Pressure Detection	0.0~200.0	30.0	sec	
14-26	Acceleration Time of Water Pressure Detection	0.1~3600.0	12.0	sec	
14-27	Deceleration Time of Water Pressure Detection	0.1~3600.0	35.0	sec	
14-28	Forced Run Command	0.00~(the value of 00-12)	0.00	Hz	
14-29	Switching Time of Water Pressure Detection	0~240	3	Hr	
14-30	Detection Time of Multiple Pumps in Parallel Running Start	0~30.0	0.0	sec	
14-31	Synchronous Selection of Multiple Pumps in Parallel	0: Disable 1: Pressure Setting Run/Stop 2: Pressure Setting 3: Run/Stop	1	-	
14-34	Tolerance Range of Constant Pressure 2	When 14-20=0, range is 0.00~650.00 When 14-20=1, range is 0~100	5	PSI/%	
14-35	Selection of Multiple Pumps Shift Operation	0: No Function 1: Timer Alternately Selection 2: Sleep Stop Alternately Selection 3: Timer and Sleep Stop Alternately Selection 4: Multiple Pumps Test Mode	1	-	
14-37	Leakage Detection Time	0.0~100.0	0.0	sec	
14-38	Pressure Variation of Leakage Detection Restart	When 14-20=0, range is 0.00~65.00 When 14-20=1, range is 0~100	1	PSI/%	
14-39	Pressure Tolerance Range of Leakage Detection Restart	When 14-20=0, range is 0.00~650.00 When 14-20=1, range is 0~100	5	PSI/%	
14-71	Maximum Pressure Setting	0.10~650.00	10	PSI	
14-72	Switching Time of Alternation in Parallel	0: Hour 1: Minute	0	-	
14-73	Slave Wake-Up Selection	0: Disable 1: Enable	0	-	
14-74	Proportion Time 2 (P)	0.00~10.00	3.00		◇
14-75	Integral Time 2 (I)	0.0~100.0	0.5		◇
14-76	Differential Time 2 (D)	0.00~10.00	0.00		◇
14-77	The Value of Water Pressure Detection	0~100	1		◇
14-78	Maximum Current Limit	0.1~6553.5	6.1	A	
14-79	Minimum Current Limit	0.1~6553.5	6.1	A	
14-80	Current limit cumulative time	0~600.0	0	Sec	

**** (Group 14 only can be used once parameter 14-00=1)**

Note: When 14-00 set to 1, 07-12 will be set to 0 at the same time. (After version 1.13)

4.3 Parameter Function Description

00- Basic parameter group

00- 00	Control mode
Range	【0】 : V/F mode 【1】 : SLV mode

Select the relevant control mode for the application, using parameter 00-00 Control mode.

Default control mode is V/F.

- **V/F mode** can be used for most applications specifically multi-motor or applications where auto tune is not successful or when a customized V/F pattern may be required.
Several V/f patterns are available selectable by parameter 01-00.
Select the appropriate V/f pattern based on the application load type and the motor base frequency of 50 or 60 Hz.
For selections of the V/f patterns. Refer to description of parameter 01-00
- **SLV (Sensor less vector)** is used for obtaining best performance from a motor. Especially at low speeds or for applications with dynamic speed change.

00- 01	Motor Direction Control
Range	【0】 : Forward 【1】 : Reverse

- 00 - 01 is valid in key pad mode only.

※Note: When Reverse function is disabled by parameter 11- 00=1 setting 00-01 to 1 ." LOC" will be displayed

00- 02	Main Run Command Source selection
00- 03	Alternative Run Command Source selection
Range	【0】 : Keypad 【1】 : External Run/Stop Control 【2】 : Communication

- Parameter 00 - 02/00- 03 sets the inverter operation command source. For switching between 00-02 and 00-03, use any of the external inputs S1 to S5 and set the relevant parameters (03-00~03-04) to [12]. Refer to parameter group3.

00- 04	Operation modes for external terminals
Range	【0】 : Forward/stop-reverse/stop 【1】 : Run/stop-forward/reverse 【2】 : 3-wire control mode run/stop 【3】 : 2-wire self-holding run/stop

- Parameter 00-04 sets the function of the External Run/Stop and it is used in conjunction with Parameters.

00-02(Main Run Source) = 1 or 00-03(Alternative Run source) = 1
(When 00-02/00-03=1, the command comes from External Run /Stop)

Parameters 03-00 to 03-04, which are used to set the required function for the digital inputs [S1 to S5] (multi-function inputs).

Note1: Parameters 03-00 to 03-04 are only required for External Run/stop
(Two wire control mode).

Note2: For External Run /Stop control set parameters in the following order:

1. 00-02 or 00-03
2. 00-04
3. 03-00 to 03-04 as required. Not required for three wire control mode.

When 00-04=0

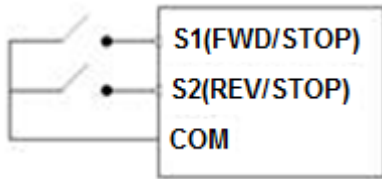

Two external switches are required, one for forward direction and the other for reverse.
Switch type: two position, maintained type. (This is two wire mode).

1. Forward (Run/Stop) Switch

Select one of the multifunction inputs [S1 to S5] and set the relevant parameter 03-00 to 03-04 = 0 (Forward run /Stop mode.)

2. Reverse (Run/Stop) Switch

Select one of the multifunction inputs [S1 to S5] and set the relevant parameter 03-00 to 03-04 = 1 (Reverse run /Stop mode.)

00-04 = 1

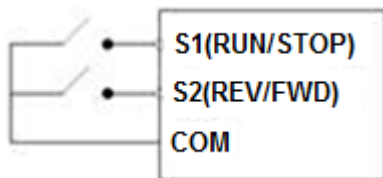

Two external switches are required.
Switch type: two position, maintained type. (This is two wire mode).

1. Run/Stop switch

Select one of the multifunction inputs [S1 to S5] and set the relevant parameter 03-00 to 03-04 = 0 (Run/Stop mode.)

2. Forward/Reverse Switch

Select one of the multifunction inputs [S1 to S5] and set the relevant parameter 03-00 to 03-04 = 1 (Forward/ Reverse direction selection.)

Switch in OFF position = Forward direction

Switch in ON position = Reverse direction

00-04= 2. Three Wire Control mode Run/Stop

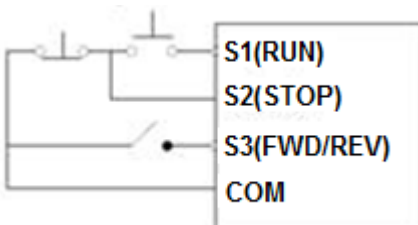

In this mode, two separated momentary push buttons are used for start and stop functions.

In this mode, parameter group 03 for S1 to S5 are not effective.

S1, S2 and S3 are allocated automatically.

Note: For S1 to initiate the Run command. Push button connected to S2 must be connected by a normally closed type (NC).

00-04 = 3, Two wire self-holding RUN/STOP
 Please see the wiring diagram and timing chart below.

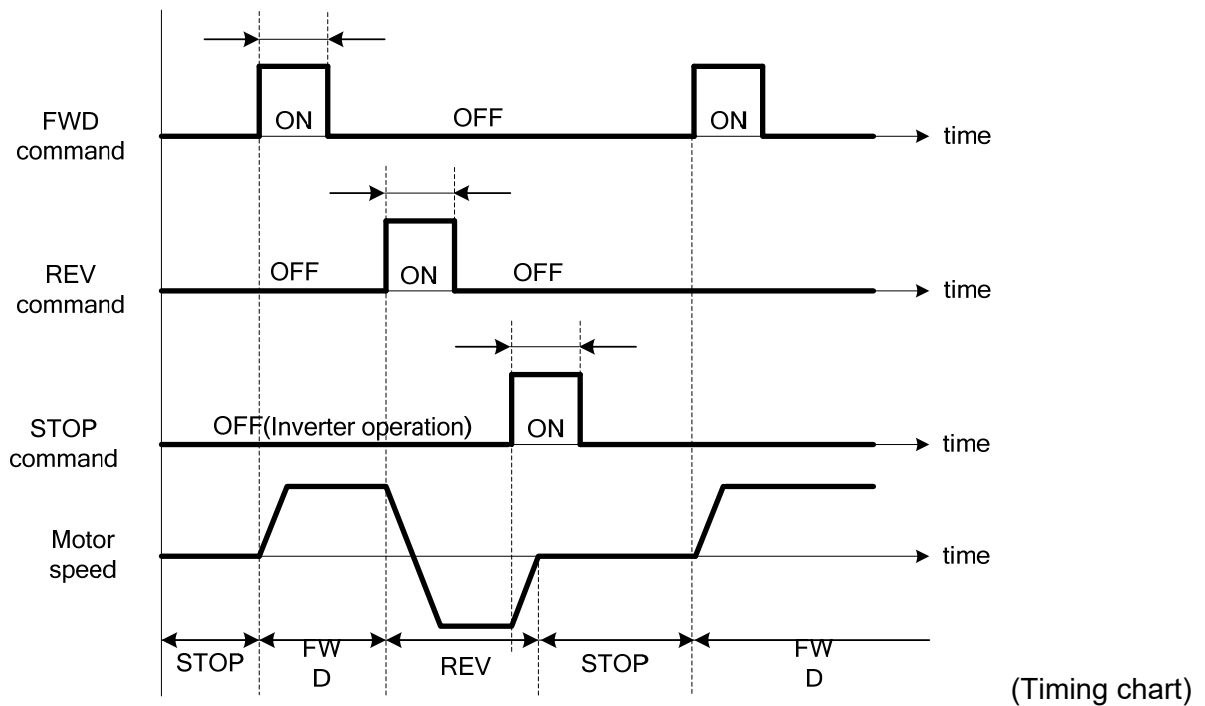
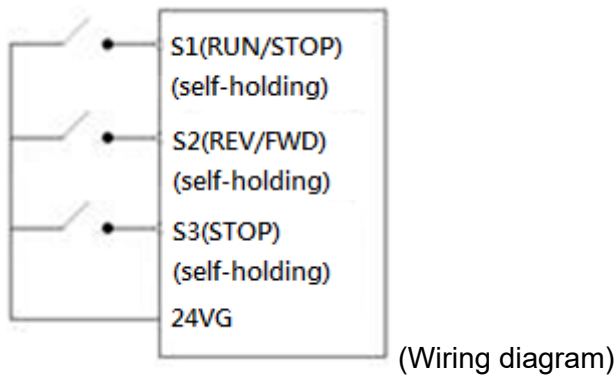

00- 05	Main Frequency Command Source Selection
00- 06	Alternative Frequency Command Source Selection
Range	<p>【 0 】 :UP/DOWN of Keypad 【 1 】 :Potentiometer on Keypad 【 2 】 :External AVI Analog Signal Input 【 3 】 :External ACI Analog Signal Input 【 4 】 :External Up/Down Frequency Control 【 5 】 :Communication setting Frequency 【 6 】 :PID Output frequency</p>

➤ Use 00- 05/00- 06 to select the source of the frequency command.

00- 07	Main and Alternative Frequency Command Modes
Range	【0】 :Main Or Alternative Frequency. 【1】 :Main frequency + Alternative Frequency

- When 00-07= **【0】** , the frequency source is set by the **Main frequency** parameter 00-05 (Default) or by the **Alternative frequency** parameter 00-06. Use any of the external terminals S1 to S5 and set the relevant parameter 03-00 to 03-04 = **【13】** to switch from **main** to **Alternative** source.
- When 00 - 07 = **【1】** The Frequency command will be the result of setting of Main & alternative frequencies.

00- 08	Communication Frequency Command
Range	【0.00~599.00】 Hz

- This parameter can be used to read the set frequency in communication mode
- This parameter is only effective in the communication mode.

00- 09	Frequency Command save on power down (Communication mode)
Range	【0】 :Disable 【1】 :Enable

- 00-09= **【0】** Keypad frequency is saved.
- 00-09= **【1】** Frequency set by communication is saved.

00-10	Initial Frequency Selection
Range	【0】 :By Current Frequency Command 【1】 :By Zero Frequency Command 【2】 :By 00-11
00-11	Initial Frequency Set point
Range	【0.00~599.00】 Hz

- This parameter is only effective in keypad mode..
- When 00-10= **【0】** ,the initial frequency will be current frequency.
- When 00-10= **【1】** ,the initial frequency will be 0.
- When 00-10= **【2】** ,the initial frequency will be as set by parameter 00-11.

00-12	Frequency Upper limit
Range	【0.01~599.00】 Hz
00-13	Frequency Lower limit
Range	【0.00~598.99】 Hz

- When 00-13 and the command frequency are both set to 0.00, if RUN is pressed, "Stop" is displayed.
- When Frequency command is > than preset in 00-13 inverter output will ramp up from 0.00 to the command frequency.
- When 00-13> 0, and the frequency command value ≤ 00-13, inverter output will ramp up from preset in lower limit to the command frequency.

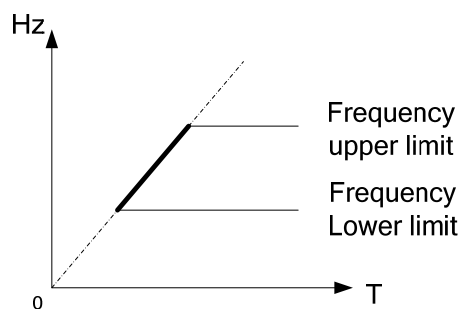

00-14	Acceleration time 1
Range	【0.1~3600.0】s
00-15	Deceleration time 1
Range	【0.1~3600.0】s
00-16	Acceleration time 2
Range	【0.1~3600.0】s
00-17	Deceleration time 2
Range	【0.1~3600.0】s

- Preset Acceleration and Deceleration times by above parameters are the time taken for the output frequency to ramp up or ramp down between the Upper and the lower V/F frequency limits.
- Actual acceleration and deceleration time is calculated as follows:

V/F mode:

$$\text{Actual acceleration time} = \frac{(00-14) \times (\text{set frequency} - \text{the minimum starting frequency})}{\text{V/F Maximum output frequency}}$$

$$\text{Actual deceleration time} = \frac{(00-15) \times (\text{set frequency} - \text{the minimum starting frequency})}{\text{V/F Maximum output frequency}}$$

SLV mode:

$$\text{Actual acceleration time} = \frac{(00-14) \times (\text{set frequency} - \text{the minimum starting frequency})}{\text{Motor rated frequency}}$$

$$\text{Actual deceleration time} = \frac{(00-15) \times (\text{set frequency} - \text{the minimum starting frequency})}{\text{Motor rated frequency}}$$

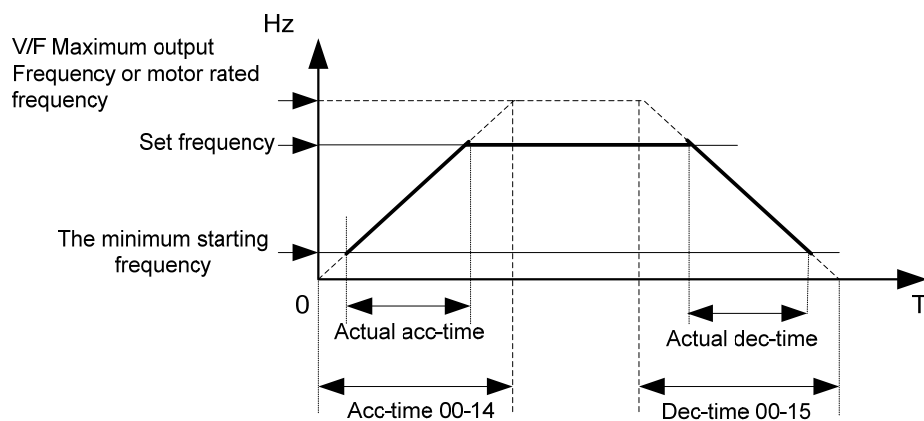

V/F Maximum output frequency is for VF curve, which can be checked from table when VF curve is fixed. Maximum output frequency is 01-02 when VF curve is customized, or motor rated frequency 02-06

00-18	Jog Frequency
Range	【 1.00~599.00 】 Hz
00-19	Jog Acceleration Time
Range	【 0.1~25.5 】 sec
00-20	Jog Deceleration Time
Range	【 0.1~25.5 】 sec

- The JOG function is operational by using the multi-function input terminals S1 to S5 and setting the relevant parameters 03-00~03-04 to **【 6 】 JOG FWD** or **【 7 】 JOG REV**. Refer to parameter group 3.

00-21	Application Field Selection
Range	【 0 】 :Disable 【 3 】 :Constant Pressure Application

- When 00-21=3, these parameters will change the default setting suitable for PUMP application. (00-14~00-15/01-00/01-04~01-07/04-00/14-00/14-24~14-27/14-74~14-77)

01-V/F command group

01-00	Volts/Hz Patterns (V/F)
Range	【1~7】

- Set 01-00 to one of the following preset V/f selections 【1~6】 according to the required application.
- Parameters 01-02~01-09 can not be modified (read only).
- Six fixed V/f patterns are shown below. 【1~3】 for 50 Hz systems and 【4~6】 for 60 Hz.

TYPE	50Hz		60Hz	
Function	01-00	V/F pattern	01-00	V/F pattern
General Use	= 【1】		= 【4】	
High start torque	= 【2】		= 【5】	
Decreasing torque	= 【3】		= 【6】	

- (V) 100% is the maximum output voltage. B, C point preset % settings will be as table below:-

01-00	Frame1/2		Frame3/4	
	B(Xb)	C(Xc)	B(Xb)	C(Xc)
1/4	10%	8%	6.8%	3.4%
2/5	12%	9.5%	6.9%	3.5%
3/6	25%	7.7%	40%	3.4%

- Setting 01-00=[7] provides a flexible V/F curve which can be selected by experienced users by setting parameters (01-02~01-09).

01-01	v/f Maximum voltage
Range	200: 【170.0~264.0】 V 400: 【323.0~528.0】 V
01-02	Maximum Frequency (base frequency)
Range	【0.2~ 599.00】 Hz
01-03	Maximum Frequency Voltage Ratio
Range	【0.0 ~ 100.0】 %
01-04	Medium Frequency 2
Range	【0.1~599.00】 Hz
01-05	Medium Frequency Voltage Ratio 2
Range	【0.0 ~ 100.0】 %
01-06	Medium Frequency 1
Range	【0.1~599.00】 Hz
01-07	Medium Frequency Voltage Ratio 1
Range	【0.0 ~ 100.0】 %
01-08	Minimum Frequency
Range	【0.1~599.00】 Hz
01-09	Minimum Frequency Voltage Ratio
Range	【0.0 ~ 100.0】 %

- Max output frequency depends on parameter 01-00, for 01-00=7, It can be set by parameter 01-02.
- For 01-00 ≠7, the maximum output frequency depends on parameter 00-12.

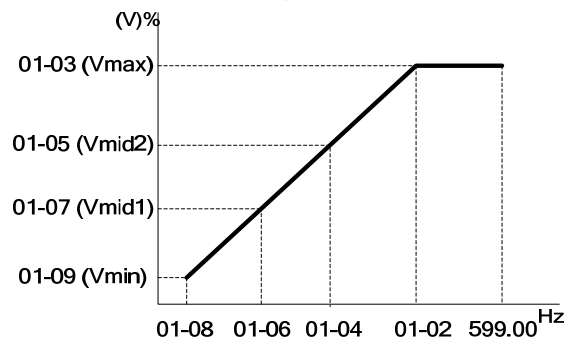

01-10	Volts/Hz Curve Modification (Torque Boost)
Range	【0 ~ 10.0】 %

- Inverter output V / F curve settings for points B, C can be adjusted by parameter 01-10 to improve the output torque.
- Calculation of B, C point voltage: B point voltage = $X_b \times$ maximum output voltage, C point voltage = $X_c \times$ maximum output voltage (X_b, X_c see the description of parameter 01-00). When 01-10 = 0, the torque improvement is disabled.

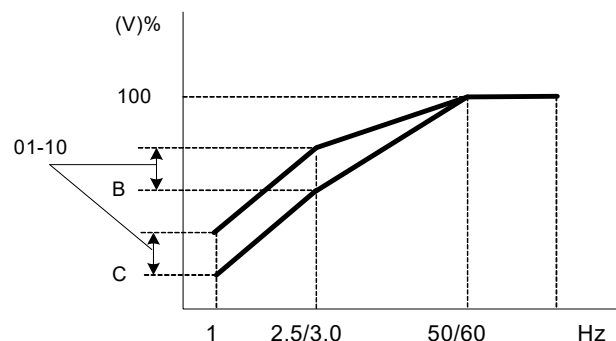

01-11	V/F start Frequency
Range	【0.00 ~10.00】 Hz

- VF Start Frequency is for occasion where Start Frequency higher than zero Hz is needed.

01-12	No-load oscillation suppression gain
Range	【0.0~200.0】 %

- In the situation of no power and no-load that damping is low, active and reactive energy fluctuations will greatly stimulate the inverter output current oscillations. Appropriately adjusting 01-12 can suppress oscillation by **frequency gain**. Compensation is based on the percentage of the load current corresponds to the motor rated current. The adjustment for 01-14 can be increased or decreased every time about 5% to 10%.

01-13	Motor Hunting Prevention Coefficient
Range	【1~8192】
01-14	Motor Hunting Prevention Gain
Range	【0~100】 %
01-15	Motor Hunting Prevention Limit
Range	【0.0~100.0】 %

- In the situation of no power and no-load that damping is low, active and reactive energy fluctuations will greatly stimulate the inverter output current oscillations. Appropriately adjusting 01-12 can suppress oscillation by compensating **V/F voltage command**. Compensation is based on high-pass filtering and the load current value, then it is multiplied by the gain limiting, finally, it is added by the V / F output voltage. The adjustment for 01-14 can be increased or decreased every time about 5% to 10%.
- 01-13 filter coefficients corresponding filter time = 2048 / set point ms, such as 01-13 = 800, then filtering time = 2048/800 = 2.56ms.
- 01-15 of 100% corresponds to 150V (100,200V series) / 300V (400V series).

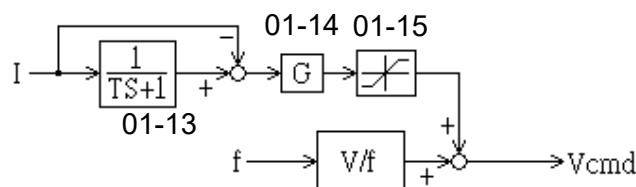

01-16	Auto-Torque Compensation Filter Coefficient
Range	【0.1 ~ 1000.0】 ms
01-17	Auto-torque Compensation Gain
Range	【0~ 100】 %
01-18	Auto-torque Compensation Frequency
Range	【1.30 ~ 5.00】 Hz

- Auto-torque Compensation function must be in **SLV mode** to auto tune so that inverter can get the value of stator resistor. Inverter Without Auto-Torque Compensation If 01-17=0. 01-17 compensation is based on V/F maximum output voltage and the load current, The adjustment for 01-14 can be increased or decreased every time about 5% to 10%.
- Parameter 01-16~01-18 is for V/F mode only. SLV mode doesn't need to adjust these parameter because auto-tune in SLV mode will get the value of motor parameter.

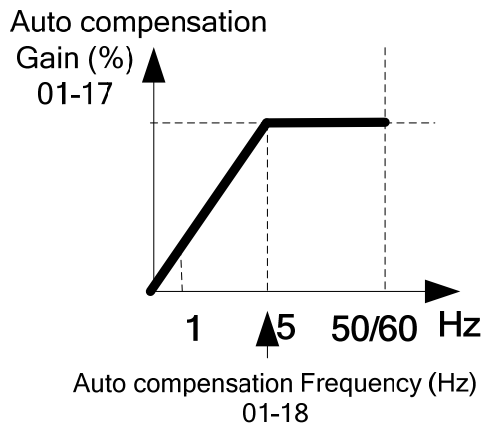

02- Motor parameter group

02- 00	Motor no load current. (For slip compensation calculation)
Range	----
02- 01	Motor Rated Current
Range	----
02- 02	Slip Compensation Gain. (V/f mode only)
Range	【0.0 ~ 100.0】 (%)

- When the load causes the actual motor speed to be reduced below the speed set by inverter output frequency (Slip), parameter 02-02 Slip compensation can be used to correct the speed.

Slip compensation calculation in V/F mode:

$$\text{Slip compensation boost} = \frac{\text{Output Current}-(02-00)}{(02-01)-(02-00)} \times (02-02) \times \text{Rate motor slip}$$

Motor slip = Motor synchronous speed - Motor Rated Speed

$$(02-02)\text{approximate Value} = \frac{\text{Motor synchronization speed} - \text{Rated speed}}{\text{Motor synchronization speed}}$$

Example: 4 poles, 60Hz induction motor synchronization speed = $\frac{120}{4} \times 60 = 1800(\text{RPM})$

- ※Note: Parameters 02- 00/02- 01 have to be set according to the specific motor data and in relation to the Inverter rating model parameter (13- 00).

02- 03	Motor Rated Speed
Range	----

- Slide compensation limit, inverter will calculate the motor slide according to 02-03. V/F slide compensation will not be higher than 02-03.

Note: Please set the value according to motor's nameplate.

02- 04	Motor Rated Voltage
Range	----

- In order to prevent the output voltage of inverter is too high. The output voltage value will not be higher than 02-04. 02-04 can be changed during operation.

Note: Please set the value according to motor's nameplate.

02- 05	Motor Rated Power
Range	【0~22.0】 kW
02- 06	Motor Rated Frequency
Range	【0~599.0】 Hz

02- 07	Motor Auto Tuning
Range	【0】 : Disable 【1】 : Static auto tuning

- When inverter executes auto tuning function, Fmax value sets by 02-06
When inverter does not execute auto tuning function, Fmax value sets by 01-02

02- 08	Stator Resistor Gain
Range	----
02- 09	Rotor Resistor Gain
Range	----

- Auto tune function in SLV mode. 00-00= **【1】** , set motor parameters 02-01 and 02-03~02-06, then set 02-07=1 to start the auto tune function. During the Auto tune function the display will show AT and show END briefly when auto tune is completed then the display will return to the frequency display. Following an auto tune the motor test data are stored in parameters 02-08&02-09 then the setting in 02-07 will automatically reset to 0.
- Carry out Auto tune again whenever replacing the motor. If the motor parameter already knew, please enter the parameter 02-01, 02-03~02-06 directly.
- Parameters 02-00 ~ 02-06 are available both for V/F & SLV mode (Except parameter 02-02 which is for V/F).
- Auto tune can be used on motors of equivalent size to the inverter or one size smaller (or one size bigger). Just need to set the motor parameter and set 02-07 to be 1.

02- 13	SLV Slip Compensation Gain
Range	【0~200】 %

- When the load causes the actual motor speed to be reduced below the speed set by inverter output frequency (Slip), parameter 02-13 SLV Slip compensation can be used to correct the speed.

02- 14	SLV Torque Compensation Gain
Range	【0~200】 %

- When torque is reduced due to load conditions, parameter 02-14 can be used to correct the torque. Torque producing current adjusted to compensate for the reduced torque. Parameter 02-13, 02-14 compensation is based on the load current. The unit of 02-13 is based on rated slip frequency; the unit of 02-14 is based on rated torque difference. The adjustment can be increased or decreased 5% to 10%.

02- 15	Low Frequency Torque Gain
Range	【0~100】 %

- Inverter of dead zone (IGBT on short) will lower the torque of output in the system, leading to lower motor efficiency. Setting 02-15 can not only reduce this situation but also increase torque of output in low frequency. Default setting is 50, means 50% voltage compensation. 100% of 02-15 according to output voltage that is less affected by dead zone.

02- 16	SLV Without Load Slip Compensation Gain
Range	【0~200】 %
02- 17	SLV With Load Slip Compensation Gain
Range	【0~200】 %

- When output current \leq 02-00 (Motor current without load), slip compensation gain :
= [SLV slip compensation gain(02-13)]* [Normal Duty slip compensation gain (02-16)]
- When output current $>$ 02-00 (Motor current with load), slip compensation gain:
= [SLV slip compensation gain(02-13)] * Slip compensation gain 1(as bellowed figure)

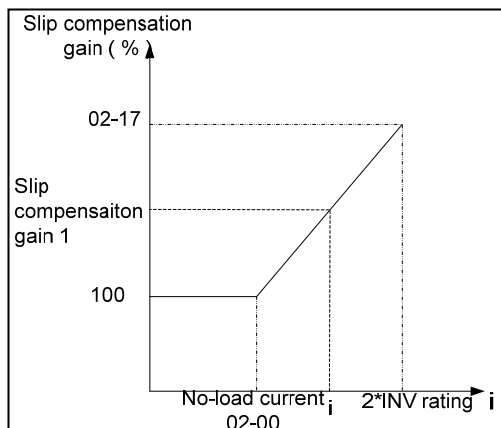

02- 18	SLV With Load Torque Compensation Gain
Range	【0~200】 %

- Please refer the contents as parameter 02-13/02-14

02- 19	SLV Slip Compensation Select
Range	0: Slip Compensation Select 1 1: Slip Compensation Select 2

- When output current lower or equal to 02-00(no load), the value of slip compensation will be equal to (02-13)*(02-16)(slip compensation select 1)
- When output current higher than 02-00(with load), the value of slip compensation will be equal to (02-13)*(02-17)(slip compensation select 2)

Note: If inverter worked at lower speed with load, please use slip compensation select 2

03- External digital inputs & Relay Output functions

03- 00	Multifunction Input Term. S1
03- 01	Multifunction Input Term. S2
03- 02	Multifunction Input Term. S3
03- 03	Multifunction Input Term. S4
03- 04	Multifunction Input Term. S5
Range	<p> 【 0 】 :Forward/Stop Command------(Parameters 00- 02/00-03=1 & 00-04) 【 1 】 :Reverse/Stop Command------(Parameters 00-02/00-03=1 & 00-04) 【 2 】 :Preset Speed setting bit 0 (5- 02)------(Parameter Group5) 【 3 】 :Preset Speed setting bit 1 (5- 03)------(Parameter Group5) 【 4 】 :Preset Speed setting bit 2 (5- 05) ------(Parameter Group5) 【 6 】 :JOG Forward Command------(Parameters 00-18~00-20) 【 7 】 :JOG Reverse Command------(Parameters 00-18~00-20) 【 8 】 :Up Command----- (Parameters 00- 05/00- 06=4& 03-06/03-07) 【 9 】 :Down Command----- (Parameters 00- 05/00- 06=4& 03-06/03-07) 【 10 】 : 2nd Acc/Dec times 【 11 】 : Disable Acc/Dec 【 12 】 : Main/ Alternative run source Select------(Parameters 00- 02/00- 03) 【 13 】 : Main/Alternative Frequency Command Select-----(Parameters 00- 05/00- 06) 【 14 】 : Rapid Stop (controlled deceleration stop) 【 15 】 : Base Block (Coast to stop) 【 16 】 : Disable PID Function.------(Parameter Goup10) 【 17 】 : Reset 【 18 】 : Enable Auto Run Mode------(Parameter Group 6) 【 19 】 : Forced Frequency Run------(Parameter Group 14) 【 20 】 : Switch to Constant Pressure 2------(Parameter Group 14) </p>

1) For setting parameters 03- 00~03- 04 to **【 0, 1 】** External Run/Stop Control, refer to 00- 04.

A. 2-wire method. Mode 1.

Example: FWD/STOP and REV/STOP from two inputs (S1&S2)

Set 00- 04= **【 0 】** , S1: 03- 00= **【 0 】** (FWD/STOP) , S2: 03- 01= **【 1 】** (REV/STOP);

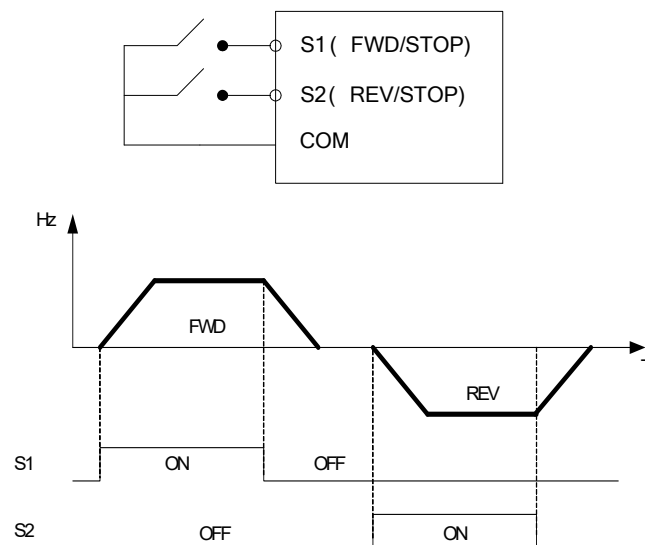

※ **Note:** If both forward and reverse commands are ON, it will be treated as a STOP signal.

B. 2-wire method. Mode 2.

Example: RUN/STOP and REV/FWD from two inputs (S1&S2)

Set 00- 04= [1] ; S1: 03- 00= [0] (RUN/STOP); S2:03- 01= [1] (REV/FWD);

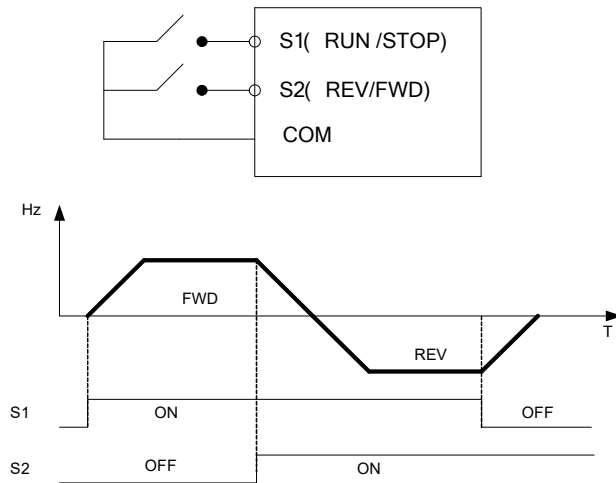

C. 3-wire method.

Example: Two separate push buttons for RUN & STOP and a two position switch for FWD/ REV

Set 00- 04=2 (3 wire control mode), then terminals S1, S2 and S3 are dedicated to this function and preset selections for parameters 03-00, 03-01 and 03-02 are not relevant.

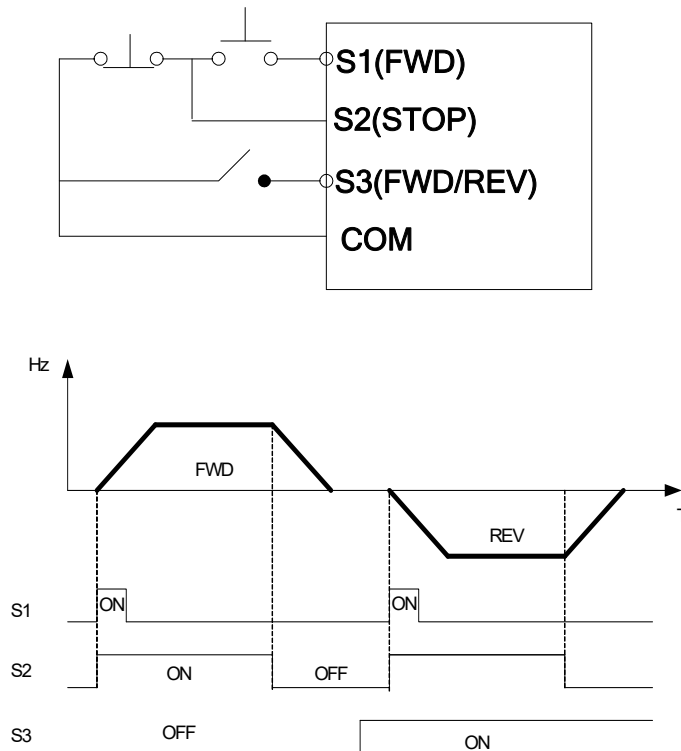

2) Parameters 03- 00~03- 04= [4, 3, 2] Preset speed selections.

Combination of any three terminals from S1~ S5 can be used to select preset speeds 0 to 7 according to the table below, for example timing diagram refer to Group 5 description.

Preset speed	Function setting and state of any three (A,B,C) of terminal S1~S5			Frequency	Acc-time	Dec-time
	terminal A=4	terminal B =3	terminal C =2			
speed 0	OFF	OFF	OFF	05- 01	05- 17	05-18
speed 1	OFF	OFF	ON	05- 02	05- 19	05-20
speed 2	OFF	ON	OFF	05- 03	05- 21	05-22
speed 3	OFF	ON	ON	05- 04	05- 23	05-24
speed 4	ON	OFF	OFF	05- 05	05- 25	05-26
speed 5	ON	OFF	ON	05- 06	05- 27	05-28
speed 6	ON	ON	OFF	05- 07	05- 29	05-30
speed 7	ON	ON	ON	05- 08	05- 31	05-32

3) 03- 00~03- 04= [6 ,7] Forward/ Reverse JOG

When an input terminal is set to function [6] and is turned on, inverter will work in jog forward mode.

When an input terminal is set to function [7] and is turned on, inverter will work in jog reverse mode.

Note: If jog forward and jog reverse function is enabled at the same time, inverter will enter stop mode.

4) 03- 00~03- 04= [8, 9] UP/DOWN

When an input terminal is set to function [8] and is turned on ,frequency command is increased according to the UP/DOWN , increment/decrement step set in parameter 03-06.

If the input is kept on continuously, the frequency command increases accordingly until the upper frequency limit is reached.

When an input terminal is set to function [9] and is turned on , frequency command decreases according to the UP/DOWN increment/decrement step set in parameter 03-06.

If the input is kept on continuously, the frequency command decreases accordingly and in relation to settings for parameter 03-06 and 3-07 until Zero speed is reached.

Refer to group 3 parameter description.

5) 03- 00~03- 04= [10] 2nd Acc/Dec time

When an input terminal is set to function [10] and is turned on ,the actual acceleration and deceleration time will be according to the time for 2nd Accel/Decel set in parameters 00-16 and 00-17.

If the input is turned off, the acceleration and deceleration times will be according to the default accel/decal 1 set in parameters 00-14 & 00-15.

6) 03- 00~03- 04= [11] Disable Acc/Dec function

When an input terminal is set to function [11] and is turned on, acceleration and deceleration function will be disabled and the frequency at the time is maintained. (Constant speed mode)

If the input is turned off, acceleration and deceleration function is enabled again.

For example, see the following diagram.

Accel/Decel & Enable/Disable timing diagram using terminal S1 and parameter 03-00 = 11.

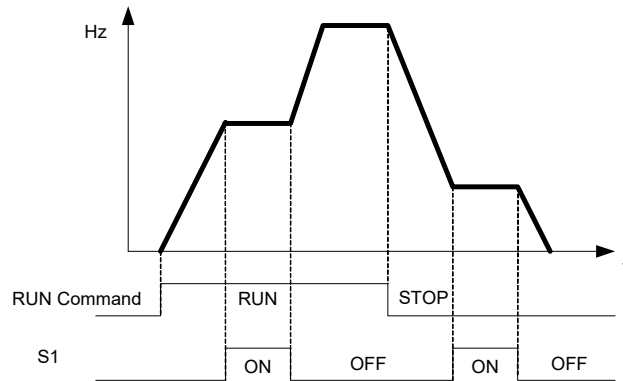

7) 03- 00~03- 04= 【12】 Main/ Alternative run source select.

When an input terminal is set to function 【12】 and is turned on, the run command source is according to parameter 00-03(Alternative Run source).If the Input is off it will be according to 00-02 (Main run source).

8) 03- 00~03- 04= 【13】 Main/ Alternative Frequency source Select

When an input terminal is set to function 【13】 and is turned on, the frequency source is according to parameter 00-06(Alternative Frequency source).If the Input is off it will be according to 00-05 (Main Frequency source).

9) 03- 00~03- 04= 【14】 Rapid Stop (controlled deceleration stop)

When DI is on, keypad shows “E.S”, motor decelerates to stop according to the setting value of 00-17. When turning off DI (remove ES), L510s stays in “stop” status. L510s runs again after giving Run command.

10) 03- 00~03- 04= 【15】 Base Block (Coast to stop)

When DI is on, keypad shows “b.b”, motor free runs to stop. When turning off DI (remove b.b), L510s starts running from 5Hz below the set frequency to 5Hz above the set frequency, then setting in set frequency.

11) 03- 00~03- 04= 【16】 Disable PID Function.

When an input terminal is set to function 【16】 and is turned on, PID functions is disabled, if it is turned off , PID function is enabled again.

12) 03- 00~03- 04= 【17】 Reset

When a failure that can be manually reset occurs, turn on a terminal with function 【17】 , the failure will be reset. (Same function as the Reset button on keypad).

13) 03- 00~03- 04= 【18】 Auto _ Run Mode

When an input terminal is set to function 【18】 , the programmable auto- sequencer function is enabled, Refer to description of parameter group 6.

14) 03- 00~03- 04= 【19】 Forced Frequency Run (PUMP application built-in version only)

This function enables with the corresponding of parameter 23-28 and the source of frequency command of parameter 00-05 set to the value of 5 (PID given, namely the parameter of 10-03 needs to be active.)

When any one of the multi-function digital input terminal (S1~S6) is set to the value of 16 (the interdiction of PID function), pump will not depend on feedback to do any PID output adjustment; simultaneously another one is set to the value of 57 (forced frequency run) and inverter will have the frequency run setting depending on the parameter of 23-28. Inverter will stop output when digital input terminals (S1~S6) are removed.

This function is applied to inverter output being controlled by external pressure sensor (E.g. differential pressure switch) when pressure sensor disconnects.

15) 03- 00~03- 04= 【20】 Switch to Constant Pressure 2 (PUMP application built-in version only)

When using in PUMP mode (14-00=1), the tolerance range of constant pressure (14-09) will be used for walking up the inverter. When digital input terminal enables, the tolerance range of constant pressure 2 (14-24) will be used.

03- 06	Up/Down frequency step
Range	【0.00~5.00】 Hz

Example: S1: 03- 00= 【8】 Up frequency command, S2: 03- 01= 【9】 Down frequency command, 03- 06= 【△】 Hz

Mode1: If UP or DOWN input terminals are turned on for less than 2 seconds, for every On operation frequency changes by △ Hz.

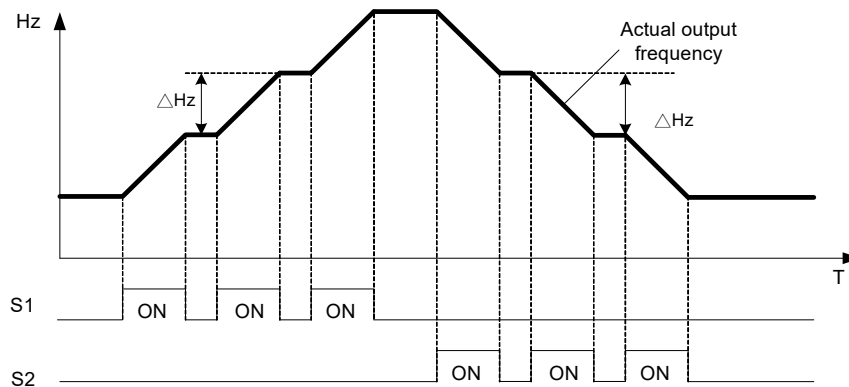

Mode 2: If UP or DOWN input terminals are turned on for more than 2Seconds, the original UP/DOWN mode is restored Output frequency Ramps up or down as long as the input is kept ON. As shown in the diagram below.

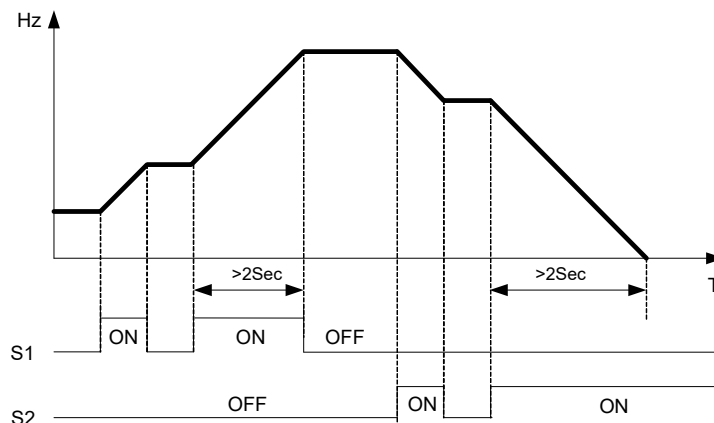

03- 07	Up/Down keep Frequency status after a stop command
Range	After a stop command in Up/Down mode: 【 0 】 : The preset frequency is held as the inverter stops. 【 1 】 : The preset frequency is reset to 0 Hz as the inverter stops. 【 2 】 : The preset frequency is held as the inverter stops, the function remains enabled.

- 03 - 07=0, when run signal is removed (Stop Command), the output frequency is stored in parameter 05-01. In stop mode since frequency can not be increased or decreased from Up/Down terminals then keypad can be used to change the frequency by modifying parameter 05-01.
- 03 - 07=1, in Up/down frequency mode inverter will ramp up from 0Hz on Run command and Ramp down to 0 Hz on stop command.
- 03-07=2, when inverter stopped, Up/down key is still valid.

03- 08	Multifunction terminals S1~S5 scan time
Range	【 1~200 】 2ms

- Multifunction input terminal On/Off periods will be scanned for the number of cycles according to the set value in parameter 03-08. If the signal status for on or off period is less than the set period it will be treated as noise.
- Scan period unit is 1ms.
- Use this parameter if unstable input signal is expected, however setting long scan time periods results in slower response times.

03- 09	s1~s5 Input type selection NO & NC
Range	【 xxxx0 】 :S1 NO 【 xxxx1 】 :S1 NC 【 xxx0x 】 :S2 NO 【 xxx1x 】 :S2 NC 【 xx0xx 】 :S3 NO 【 xx1xx 】 :S3 NC 【 x0xxx 】 :S4 NO 【 x1xxx 】 :S4 NC 【 0xxxx 】 :S5 NO 【 1xxxx 】 :S5 NC

- (NO) Normally open, (NC) Normally closed. Select as required.
- For selecting Normally Open (NO) or Normally Closed(NC) set the relevant digit in parameter 03-09 to 0 or 1 as required.
- Set Parameter 03-09 first before you use the Parameters 00-02/00-03=1 to set the inverter run mode to External multifunction inputs.

Note: Before the setting terminal is connected to the normally open/normally closed switch, do not set the running command to come from the external terminal, otherwise it will cause unnecessary damage.

03-11	Multifunction Output Relay RY1 functions. (Terminals RB, RA)
Range	【0】 :Run 【1】 :Fault 【2】 :Setting Frequency Reached -----(refer to 03-14) 【3】 :Frequency Reached (3-13±3-14) -----(refer to 03-13/03-14) 【4】 :Output Frequency Detection 1 (> 03-13) -----(refer to 03-13) 【5】 :Output Frequency Detection 2 (< 03-13) -----(refer to 03-13) 【6】 :Auto-Restart 【7】 :Momentary AC Power Loss----- (refer to 07-00) 【8】 :Rapid Stop (Decelerate to Stop) 【9】 :Base Block 【10】 :Motor Overload Protection (OL1) 【11】 :Drive Overload Protection (OL2) 【12】 :Reserved 【13】 :Output Current Reached -----(refer to 03-15/03-16) 【14】 :Brake Control----- (refer to 03-17/03-18) 【15】 :PID Feedback Disconnection Detection -----(refer to 10-11/10-13) 【16】 :High Pressure Detection 【17】 :Low Pressure Detection 【18】 :Pressure Loss Detection
03-13	Frequency Detection Level
Range	【0.00~599.00】 Hz
03-14	Frequency Detection Width
Range	【0.00~30.00】 Hz

Output relay RY1. function descriptions:

- 1) 03-11 = **【0】** . RY1 will be ON with run signal.
- 2) 03-11 = **【1】** . RY1 will be ON with inverter faults.
- 3) 03-11 = **【2】** . RY1 will be ON when output frequency reached setting frequency.

When Output Freq. = Setting Frequency - Frequency Detection Width (03-14),
Relay Output will be ON.

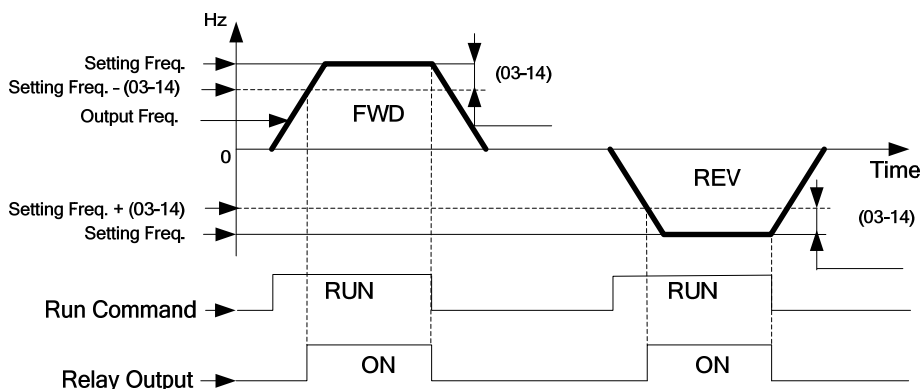

Example :

Setting Freq. =30, and Frequency Detection Width (03-14) =5, relay will be ON when output frequency reached 25Hz to 30Hz and Run Command is on (Allowable tolerance ±0.01).

- 4) **03-11=【3】** RY1 will be ON when Setting Freq. and Output Frequency reached (03-13 +/- 03-14).

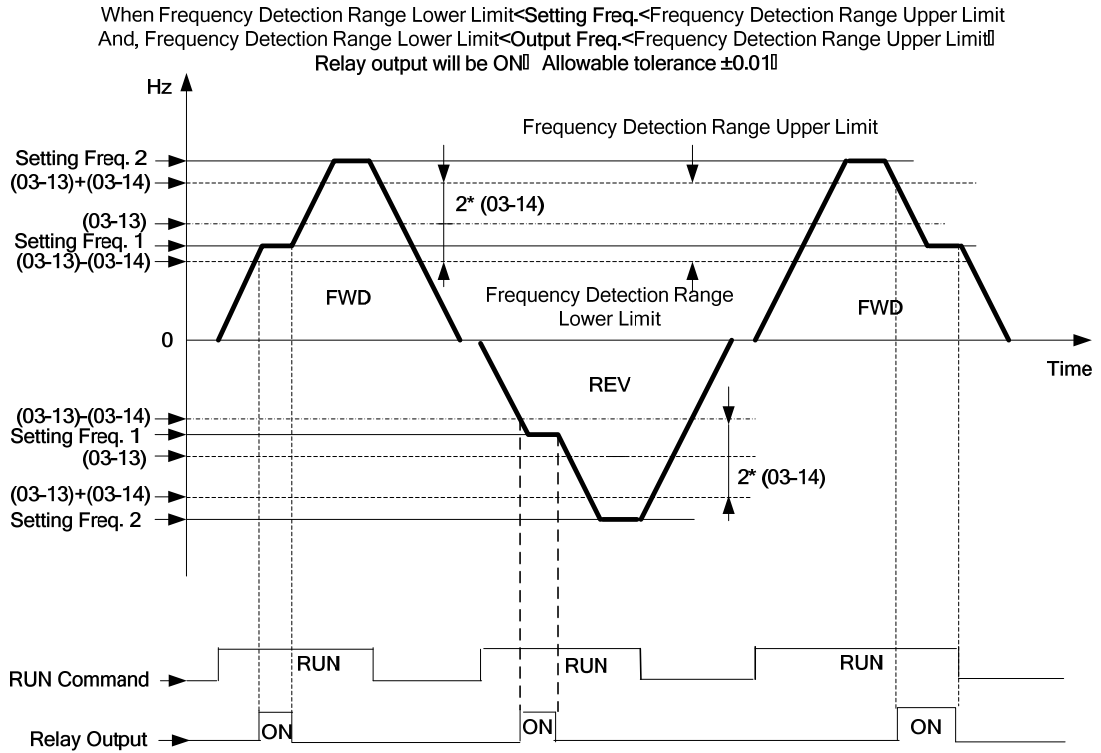

Example:

Frequency Detection Level (03-13) = 30, and Frequency Detection Width (03-14) = 5 cause frequency detection range upper limit = 35, and Frequency Detection Range lower limit = 25. So RY1 will be on when Setting Freq. and Output Freq. are both under these limits; on the other hand, RY1 will be off when Setting Freq. and Output Freq. are not under these limits either.

- 5) **03-11=【4】**, RY1 will be on while Output Freq. > Frequency Detection Level (03-13).

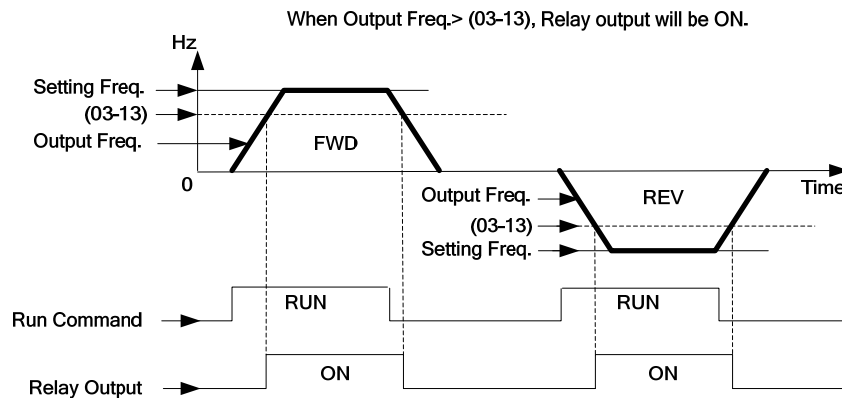

6) **03-11=【5】** . RY1 will be on while Output Freq. < Frequency Detection Level (03-13).

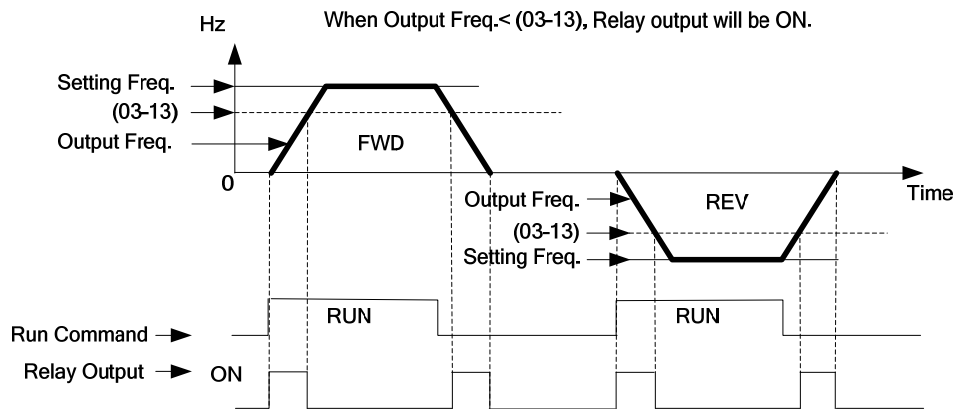

7) **03-11=【16】** , High Pressure Detection, please refer parameter setting of 14-12~14-14

8) **03-11=【17】** , Low Pressure Detection, please refer parameter setting of 14-15~14-17

9) **03-11=【18】** , Pressure Loss Detection, please refer parameter setting of 14-18~14-19

03-15	Output Current Detection Level
Range	【0.1~999.9】 A
03-16	Output Current Detection Period
Range	【0.1~10.0】 Sec

- 03-11=【13】 , RY1 will be on as soon as the output current value > Output current detection level (03-15).
- 03-15: Setting range (0.1~15.0 Amps) as required according to the rated motor current.
- 03-16: Setting range (0.1~10.0) unit: seconds.

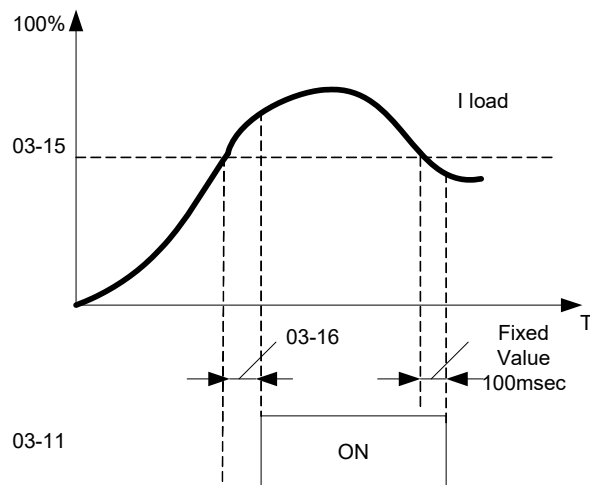

03-17	Braking Release Level
Range	【0.00~20.00】 Hz
03-18	Braking Engage Level
Range	【0.00~20.00】 Hz

- If 03-11 = **【14】**
 - (a) In accelerating mode, RY1 will be ON as soon as the actual output frequency reaches the external Braking release level set in parameter 03-17.
 - (b) In decelerating mode, RY1 will be OFF as soon as the actual output frequency reaches the external Braking engage level set in parameter 03-18.

Timing diagram for 03-17 < 03-18 is shown below:

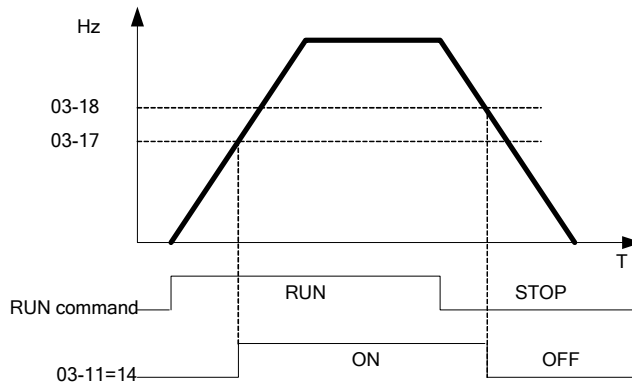

Timing diagram for 03-17 > 03-18 is shown below:

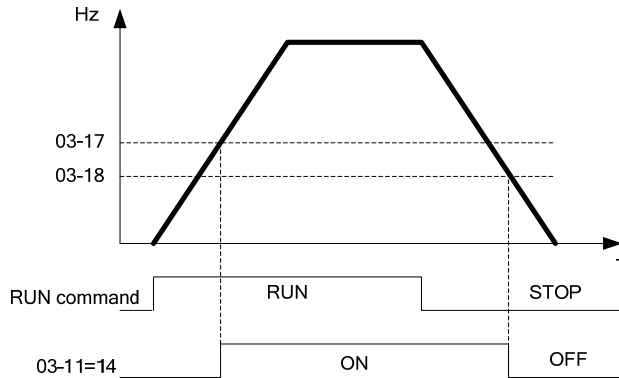

03-19	Relay Output Status type
Range	【0】 : A (Normally open) 【1】 : B (Normally close)
03-20	Braking Transistor ON Level
Range	100V/200V: 【240.0~400.0】 VDC 400V: 【500.0~800.0】 VDC
03-21	Braking Transistor OFF Level
Range	100V/200V: 【240.0~400.0】 VDC 400V: 【500.0~800.0】 VDC

- When DC bus voltage > 03-20, Excess voltage will be applied to the external braking resistor.
- When DC bus voltage ≤ 03-21, braking transistor will be switched off.
- Do not set 03-21 > 03-20, or display will show Err2, which means parameter setting error.

04- External analog signal input / output functions

04- 00	Analog Voltage & Current input selections	
	AVI	ACI
Range	[0] :0~10V	0~20mA
	[1] :0~10V	4~20mA
	[2] :2~10V	0~20mA
	[3] :2~10V	4~20mA

➤ **Analog Input Scaling formulas:-**

AVI(0~10V), ACI(0~20mA)

$$\text{AVI}(0\sim 10\text{V}):F(\text{Hz}) = \frac{V(\text{v})}{10(\text{v})} \times X(00-12)$$

$$\text{ACI}(0\sim 20\text{mA}):F(\text{Hz}) = \frac{I(\text{mA})}{20(\text{mA})} \times X(00-12)$$

AVI(2~10V), ACI(4~20mA)

$$\text{AVI}(2\sim 10\text{V}):F(\text{Hz}) = \frac{V-2(\text{v})}{10-2(\text{v})} \times X(00-12)$$

$$\text{ACI}(4\sim 20\text{mA}):F(\text{Hz}) = \frac{I-4(\text{mA})}{20-4(\text{mA})} \times X(00-12)$$

04- 01	AVI signal verification Scan Time
Range	[1~200] 2ms
04- 02	AVI Gain
Range	[0 ~ 1000] %
04- 03	AVI Bias
Range	[0~ 100] %
04- 04	AVI Bias Selection
Range	[0] : Positive [1] : Negative
04- 05	AVI Slope
Range	[0] : Positive [1] : Negative
04- 06	ACI signal verification Scan Time
Range	[1~200] 2ms
04- 07	ACIGain
Range	[0 ~ 1000] %
04- 08	ACI Bias
Range	[0 ~ 100] %
04- 09	ACI Bias Selection
Range	[0] : Positive [1] : Negative
04-10	ACI Slope
Range	[0] : Positive [1] : Negative

➤ Set 04- 01 and 04- 06 for Analog signal verification.

Inverter reads the average values of A/D signal once per (04- 01/04- 06 x 2ms). Set scan intervals according to the application and with consideration for signal instability or interference effects on the signal by external sources. Long scan times will result in slower response time.

- AVI example (analog voltage input) by adjusting Gain, Bias & Slope parameters (04-02~04-05).
- (1) Positive Bias type (04-04= 0) and effects of modifying Bias amount by parameter 04-03 and Slope type with parameter 04-05 are shown in Fig 1&2.

Figure 1.

	04- 02	04- 03	04- 04	04- 05
A	100%	50%	0	0
B	100%	0%	0	0

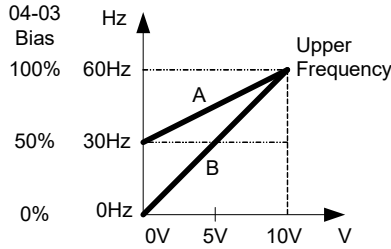
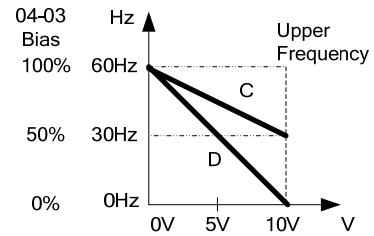

Figure 2.

	04- 02	04- 03	04- 04	04- 05
C	100%	50%	0	1
D	100%	0%	0	1



Negative Bias type and effects of modifying Bias amount by parameter 04-03 and Slope type with parameter 04-05 are shown in Fig 3&4.

Figure3:

	04- 02	04- 03	04- 04	04- 05
E	100%	20%	1	0

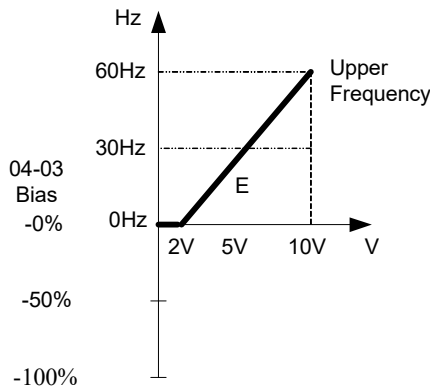
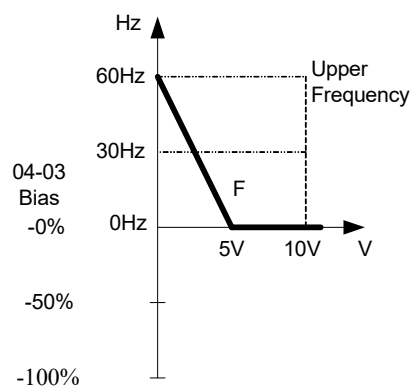

Figure4:

	04- 02	04- 03	04- 04	04- 05
F	100%	50%	1	1



- (2) Offset bias set to 0% (04-03) and effect of modifying Analog Gain (04-02), Bias type (04-04) and slope type(04-05) are shown in shown Fig 5&6.

Figure 5

	04- 02	04- 03	04- 04	04- 05
A'	50%	0%	0/1	0
B'	200%	0%	0/1	0

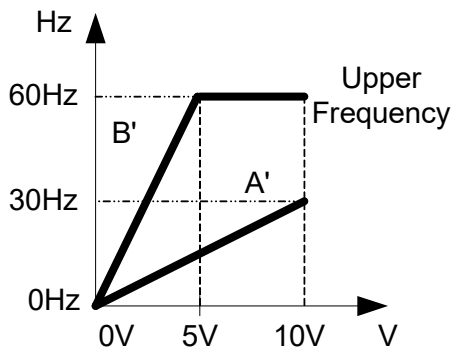
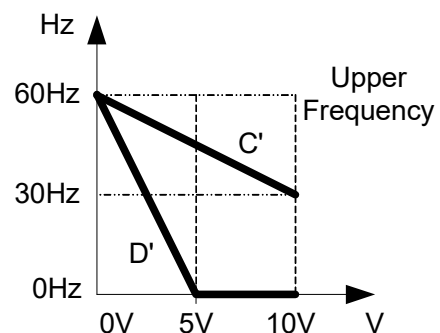

Figure 6

	04- 02	04- 03	04- 04	04- 05
C'	50%	0%	0/1	1
D'	200%	0%	0/1	1



(3) Various other examples of analog input scaling and modification are shown in following figures 7,8,9 & 10.

Figure 7

	04- 02	04- 03	04- 04	04- 05
a	50%	50%	0	0
b	200%	50%	0	0

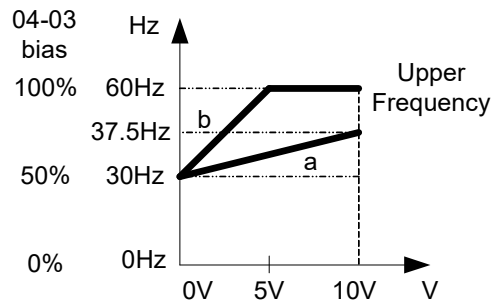

Figure 8

	04- 02	04- 03	04- 04	04- 05
c	50%	50%	0	1
d	200%	50%	0	1

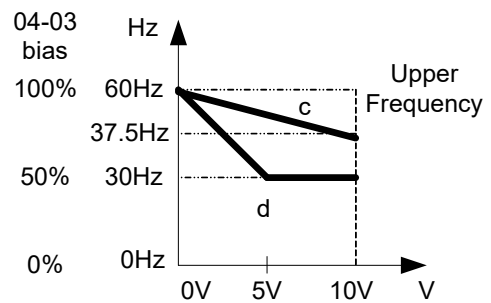

Figure 9

	04- 02	04- 03	04- 04	04- 05
e	50%	20%	1	0
f	200%	20%	1	0

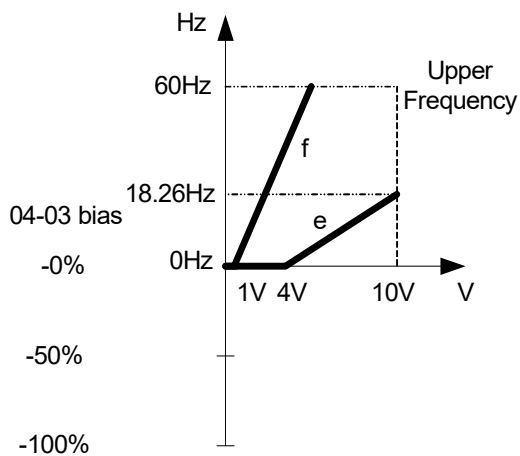
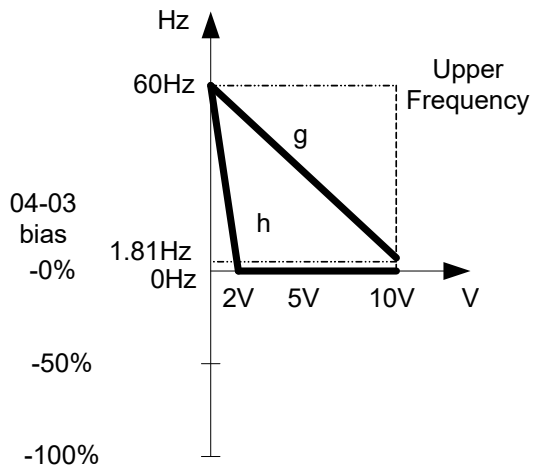

Figure 10

	04- 02	04- 03	04- 04	04- 05
g	50%	50%	1	1
h	200%	0%	0	1



04-11	Analog Output (AO) function selection.
Range	【0】 :Output frequency 【1】 :Frequency Setting 【2】 :Output voltage 【3】 :DC Bus Voltage 【4】 :Output current

Example: Set 04-11 required according to the following table.

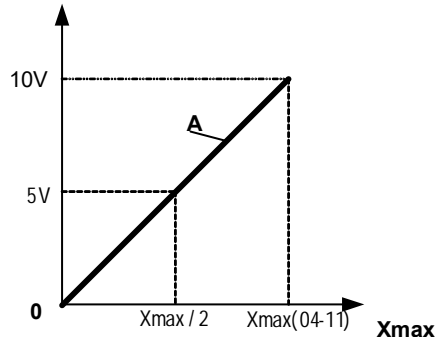

04-11	A	Xmax
【0】	Output frequency	upper frequency limit
【1】	Frequency Setting	upper frequency limit
【2】	Output voltage	Motor Rated Voltage
【3】	DC Bus Voltage	220V: 0~400V 380V: 0~800V
【4】	Output current	2 times rated current of inverter

04-12	AO Gain
Range	【0 ~ 1000】 %
04-13	AO Bias
Range	【0 ~ 100】 %
04-14	AO Bias Selection
Range	【0】 : Positive 【1】 : Negative
04-15	AO Slope
Range	【0】 : Positive 【1】 : Negative

- Select the Analog output type for the multifunction analog output on terminal (TM2) as required by parameter 04-11. Output format is 0-10Vdc. The output voltage level can be scaled and modified by parameters 04-12 to 04-15 If necessary.
- The modification format will be same as the examples shown previously for Analog Voltage Input (AVI) parameters 4-02 to 4-05.

Note: the max output voltage is 10V due to the hardware of the circuit.

Use external devices that require a maximum of 10V dc signal.

04-16	Potentiometer Gain on Keypad
Range	【0 ~ 1000】 %
04-17	Potentiometer Bias on Keypad
Range	【0 ~ 100】 %
04-18	Potentiometer Bias Selection on Keypad
Range	【0】 : Positive 【1】 : Negative
04-19	Potentiometer Slope on Keypad
Range	【0】 : Positive 【1】 : Negative

05- Preset Frequency Selections.

05- 00	Preset Speed Control mode Selection
Range	【 0 】 :Common Acceleration / Deceleration. 【 1 】 : Individual Acceleration / Deceleration for each preset speed 0-7.

05- 01	Preset Speed 0 (Keypad Freq.)
05- 02	Preset Speed 1
05- 03	Preset Speed 2
05- 04	Preset Speed 3
05- 05	Preset Speed 4
05- 06	Preset Speed 5
05- 07	Preset Speed 6
05- 08	Preset Speed 7
Range	【 0.00 ~ 599.00 】 Hz
05-17	Preset Speed 0 Acceleration time
05-18	Preset Speed 0 Deceleration time
05-19	Preset Speed 1 Acceleration time
05- 20	Preset Speed 1 Deceleration time
05- 21	Preset Speed 2 Acceleration time
05- 22	Preset Speed 2 Deceleration time
05- 23	Preset Speed 3 Acceleration time
05- 24	Preset Speed 3 Deceleration time
05- 25	Preset Speed 4 Acceleration time
05- 26	Preset Speed 4 Deceleration time
05- 27	Preset Speed 5 Acceleration time
05- 28	Preset Speed 5 Deceleration time
05- 29	Preset Speed 6 Acceleration time
05- 30	Preset Speed 6 Deceleration time
05- 31	Preset Speed 7 Acceleration time
05- 32	Preset Speed 7 Deceleration time
Range	【 0.1 ~ 3600.0 】 s

- When 05- 00 = 【 0 】 Acceleration /Deceleration 1 or 2 set by parameters 00-14/00-15 or 00-16/00-17 apply to all speeds.
- When 05- 00 = 【 1 】 Individual Acceleration /Deceleration apply to each preset speed 0-7. Parameters 05-17 to 05-32.
- Formula for calculating acceleration and deceleration time:

V/F mode:

$$\text{Actual Acc time} = \frac{\text{Time of Accel1 or 2 x Preset Frequency}}{\text{V/F Max Frequency}}$$

$$\text{Actual Dec time} = \frac{\text{Time of Accel1 or 2 x Preset Frequency}}{\text{V/F Max Frequency}}$$

SLV mode:

$$\text{Actual Acc time} = \frac{\text{Time of Accel1 or 2 x Preset Frequency}}{\text{Motor rated output frequency}}$$

$$\text{Actual Dec time} = \frac{\text{Time of Accel1 or 2 x Preset Frequency}}{\text{Motor rated output frequency}}$$

- V/F Maximum output frequency=parameter 01-02 when programmable V/F is selected by 01-00=【7】 , Motor rated output frequency is set by parameter 02-06.
- V/F Maximum output frequency = 50.00 hz or 60.00 hz when preset V/F patterns are selected. 01-00≠【7】 .

Bellowing examples is in V/F mode:

Example 01-00≠7, 01-02=50Hz, 05-02=10Hz (preset speed1),
05-19=5s (Accel time), 05-20=20s (Decel time)

$$\text{Preset speed 1 Actual Accel time} = \frac{(05-19) \times 10(\text{Hz})}{01-02} = 1(\text{s})$$

$$\text{Preset speed 1 Actual Deccel time} = \frac{(05-20) \times 10(\text{Hz})}{01-02} = 4(\text{s})$$

- **Multi speed run/stop cycles with Individual acceleration/deceleration time. 05-00=【1】**
- Two modes are shown below:-
- Mode1 = On/Off run command
- Mode2= Continuous run command

Mode1 Example: 00-02=【1】 (External Run/Stop Control).
00-04=【1】 (Operation Mode : Run/stop-forward/reverse).
S1: 03-00=【0】 (RUN/STOP);
S2: 03-01=【1】 (Forward/Reverse);
S3: 03-02=【2】 (Preset speed 1);
S4: 03-03=【3】 (Preset speed 2);
S5: 03-04=【4】 (Preset speed 4);

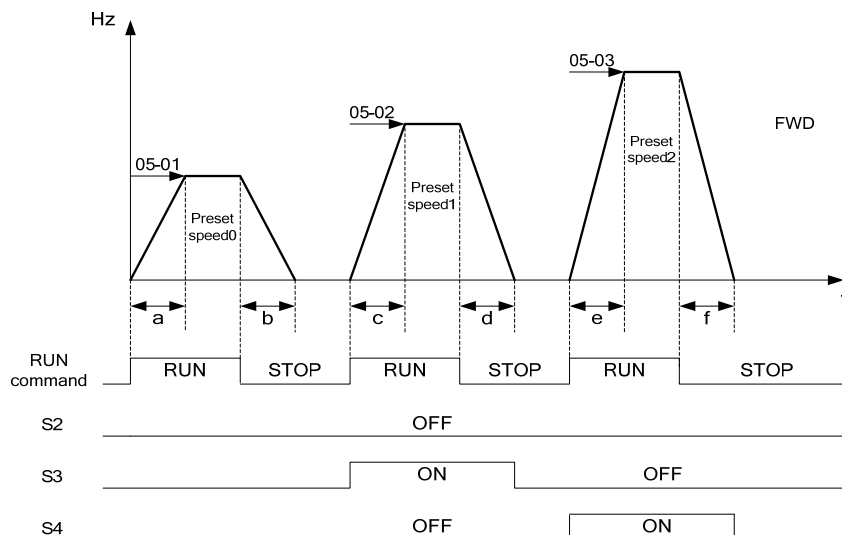

When the run command is On/Off, acceleration and deceleration times for each cycle can be calculated as below:- time unit is in seconds'.

$$a = \frac{(05-17) \times (05-01)}{01-02}, b = \frac{(05-18) \times (05-01)}{01-02}, c = \frac{(05-19) \times (05-02)}{01-02}, d = \frac{(05-20) \times (05-02)}{01-02} \dots\dots$$

Mode2 Example. Continuous run command.

- Set S1 for Continuous Run
- Set S2 For Forward /Reverse direction selection
- Set multi function terminals S3,S4 & S5 for setting three different preset speeds

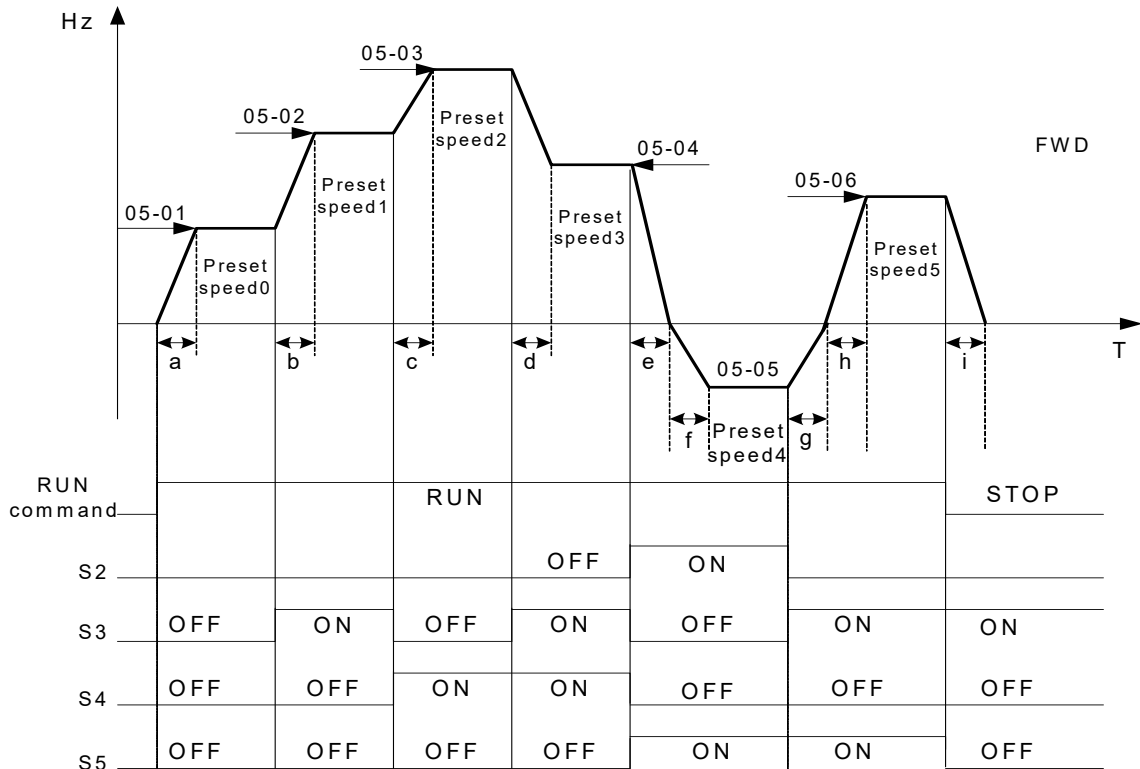

When the run command is continuous, acceleration and deceleration times for each segment can be calculated as below:-

$$\text{Ex] } a = \frac{(05-17) \times (05-01)}{01-02}, b = \frac{(05-19) \times [(05-02) - (05-01)]}{01-02}$$

$$c = \frac{(05-21) \times [(05-03) - (05-02)]}{01-02}, d = \frac{(05-24) \times [(05-03) - (05-04)]}{01-02}$$

$$e = \frac{(05-26) \times (05-05)}{01-02}, f = \frac{(05-28) \times (05-05)}{01-02}, g = \frac{(05-27) \times (05-05)}{01-02}$$

$$h = \frac{(05-29) \times (05-05)}{01-02}, i = \frac{(05-32) \times (05-05)}{01-02} \dots\dots \text{Unit(sec)}$$

06- Auto Run(Auto Sequencer) function

06- 00	Auto Run(sequencer) mode selection
Range	<p>【0】 :Disabled</p> <p>【1】 :Single cycle, continues to run from the unfinished step if restarted.</p> <p>【2】 :Periodic cycle, continues to run from the unfinished step if restarted.</p> <p>【3】 :Single cycle, then holds the speed of final step to run. Continues to run from the unfinished step if restarted.</p> <p>【4】 :Single cycle, starts a new cycle if restarted.</p> <p>【5】 :Periodic cycle, starts a new cycle if restarted.</p> <p>【6】 :Single cycle, then hold the speed of final step to run, starts a new cycle if restarted.</p>

Frequency of the step 0 is set by parameter 05-01 keypad Frequency.

06- 01	Auto Run Mode Frequency Command 1
06- 02	Auto Run Mode Frequency Command 2
06- 03	Auto Run Mode Frequency Command 3
06- 04	Auto Run Mode Frequency Command 4
06- 05	Auto Run Mode Frequency Command 5
06- 06	Auto Run Mode Frequency Command 6
06- 07	Auto Run Mode Frequency Command 7
Range	【0.00 ~ 599.00】 Hz

06- 16	Auto Run Mode Running Time Setting0
06- 17	Auto Run Mode Running Time Setting1
06- 18	Auto Run Mode Running Time Setting2
06- 19	Auto Run Mode Running Time Setting3
06- 20	Auto Run Mode Running Time Setting4
06- 21	Auto Run Mode Running Time Setting5
06- 22	Auto Run Mode Running Time Setting6
06- 23	Auto Run Mode Running Time Setting7
Range	【0.00 ~ 3600.0】 Sec

06- 32	Auto Run Mode Running Direction0
06- 33	Auto Run Mode Running Direction1
06- 34	Auto Run Mode Running Direction2
06- 35	Auto Run Mode Running Direction3
06- 36	Auto Run Mode Running Direction4
06- 37	Auto Run Mode Running Direction5
06- 38	Auto Run Mode Running Direction6
06- 39	Auto Run Mode Running Direction7
Range	<p>【0】 : STOP</p> <p>【1】 : Forward</p> <p>【2】 : Reverse</p>

- Auto Run sequencer mode has to be enabled by using one of the multifunctional inputs S1 to S5 and setting the relevant parameter 03-00 to 03-04 to selection **【18】** .
- Various Auto Run (sequencer) modes can be selected by parameter (06-00) as listed above.
- 7 Auto Run (sequencer) modes can be selected by parameters (06-01~06-39)
- Auto Run frequency commands1 to 7 are set with Parameters (06-01~06-07),

- Sequence run times are set with parameters (06-17~ 06-23)
- FWD/REV Direction for each sequence can be set with parameters (06-33 ~ 06-39).
- Auto sequence 0, frequency is set from keypad by parameter 05-01, sequence run time and direction are set by parameters 06-16 and 06-32.

Auto RUN (Auto Sequencer) examples are shown in the following pages:-

Example 1. Single Cycle (06- 00=1, 4)

The inverter will run for a single full cycle based on the specified number of sequences, then it will stop. In this example 4 sequences are set, three in forward direction and one in Reverse.

Auto Run Mode	06-00=1 or 4
Frequency	05-01=15Hz, 06-01=30Hz, 06-02=50Hz, 06-03=20Hz
Sequence Run Time	06-16=20s, 06-17=25s, 06-18=30s, 06-19=40s
Direction	06-32=1(FWD), 06-33=1(FWD), 06-34=1(FWD), 06-35=2(REV)
Unused Sequence Parameters	06-04~06-07=0Hz, 06-20~06-23=0s, 06-36~06-39=0

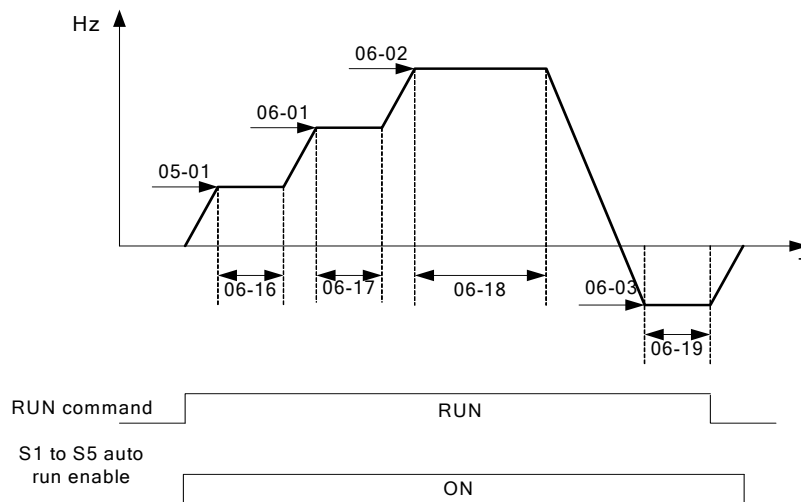

Example 2. Periodic cycle Run.

Mode: 06-00=2 or 5

The inverter will repeat the same cycle periodically.

All other Parameters are set same as Example 1. shown above.

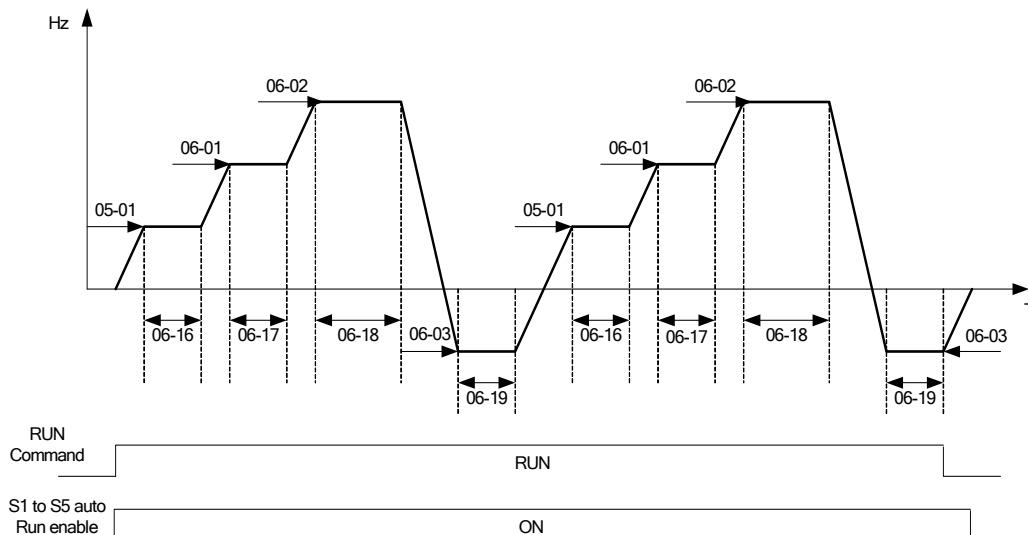

Example 3. Auto_Run Mode for Single Cycle 06-00=3 or 6

The speed of final step will be held to run.

Auto Run Mode 06-00=3 or 6
 Frequency 05-01=15Hz, 06-01=30Hz, 06-02=50Hz, 06-07=20Hz
 Sequence Run Time 06-16=20s, 06-17=25s, 06-18=30s, 06-23=40s
 Direction 06-32=1(FWD), 06-33=1, 06-34=1, 06-39=1
 Unused Sequence Parameters 06-03~06-06=0Hz, 06-19~06-22=0s, 06-35~06-38=0

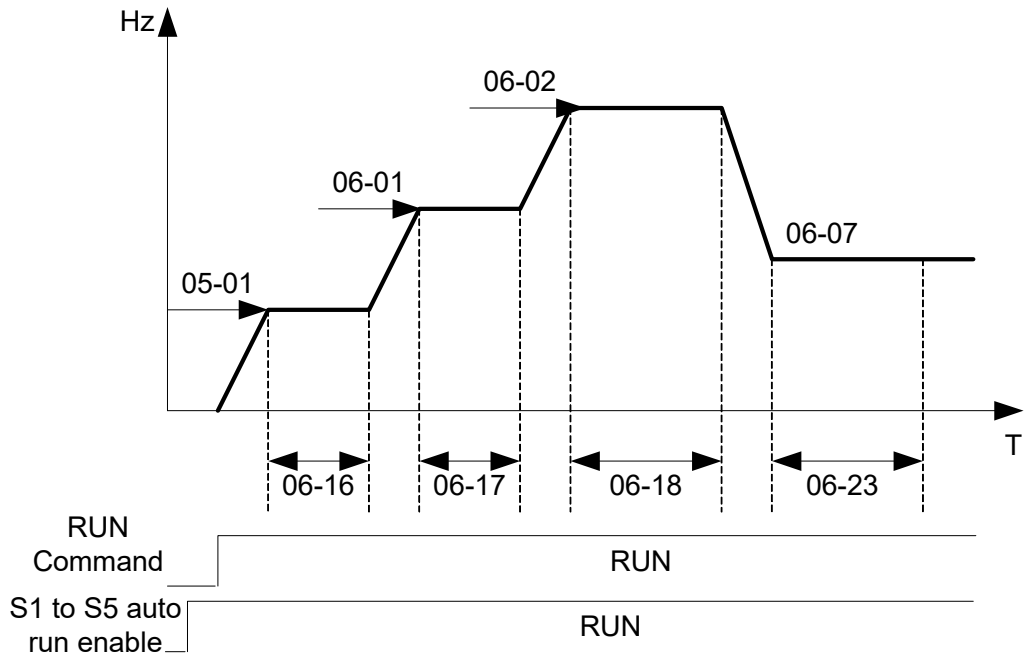

Example 4 & 5 .

Auto Run Mode 06-00=1~3, after a restart continues to run from the unfinished step.

Auto Run Mode 06-00=4~6, after a restart, it will begin a new cycle.

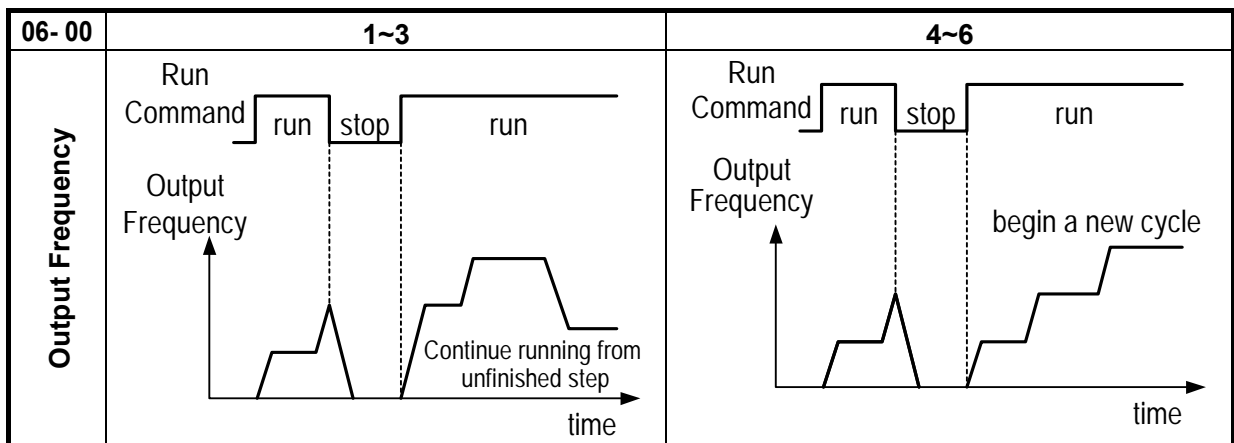

- ACC/DEC time in Auto run mode will be according to the setting of 00-14/00-15 or 00-16/00-17.
- For Auto sequence 0.The run frequency will be according to keypad frequency set by parameter 05-01.Parameters 06-16 and 06-32 are used to set the sequence Run time and Run direction.

07- Start/Stop command setup	
07- 00	Momentary power loss and restart
Range	【 0 】 :Momentary Power Loss and Restart disable 【 1 】 :Momentary power loss and restart enable

- If the input power supply due to sudden increase in supply demand by other equipment results in voltage drops below the under voltage level, the inverter will stop its output at once.
- When 07-00=0, on power loss, the inverter will not start.
- When 07-00=1, after a momentary power loss, inverter will restart with the same frequency before power loss, and there is no limitation on number of restarts.
- On power loss, as long as the inverter CPU power is not completely lost, the momentary power loss restart will be effective, restart will be according to setting of parameters 00-02 & 07-04 and status of External run switch.

Caution:

After any power loss if the Run mode is set to External by parameter 00-02=1 and if Direct start on power up is also selected by parameter 07-04=0, please note that the inverter will run on resumption of power.

To ensure safety of operators and to avoid any damages to the machinery, all necessary safety measure must be considered, including disconnection of power to the inverter.

07- 01	Auto Restart Delay Time
Range	【 0.0~6000.0 】 Sec
07- 02	Number of Auto Restart Attempts
Range	【 0~10 】

- 07-02=0: The inverter will not auto restart after trips due to fault.
- 07-02>0, 07- 01=0, after a trip due to fault the inverter will run with the same frequency before power loss, and restarts after an internal delay of 0.5 seconds.
- 07-02>0, 07- 01>0, after a fault trip the inverter will run with the same frequency before power loss, and restart with a delay according the preset in parameter 07-01.
- **Note:**
Auto restart after a fault will not function while DC injection braking or decelerating to stop

07- 03	Reset Mode Setting
Range	【 0 】 :Enable Reset Only when Run Command is Off 【 1 】 :Enable Reset when Run Command is On or Off

- 07-03=0 Once the inverter is detected a fault, please turn Run switch Off and then On again to perform reset, otherwise restarting will not be possible.

07- 04	Direct Running on Power Up
Range	【 0 】 :Enable Direct running after power up 【 1 】 :Disable Direct running after power up

07-05	Delay-ON Timer (Seconds)
Range	【1.0~300.0】 Sec

- When direct run on power up is selected by 07-04=0 and the inverter is set to external run by (00-02/00-03=1), if the run switch is ON as power is applied, the inverter will auto start. It is recommend that the power is turned off and the run switch is also off to avoid possibility of injury to operators and damage to machines as the power is reapplied.

Note: If this mode is required all safety measures must be considered including warning labels.

- When direct run on power up is disabled by 07-04=1 and if the inverter is set to external run by (00-02/00-03=1), if the run switch is ON as power is applied, the inverter will not auto start and the display will flash with STP1. It will be necessary to turn OFF the run switch and then ON again to start normally.

07-06	DC Injection Brake Start Frequency (Hz)
Range	【0.10 ~ 10.00】 Hz

- When DC Injection braking is active DC voltage is applied to the motor, increasing the braking current and resulting in an increase in the strength of the magnetic field trying to lock the motor shaft.
- To enable DC injection braking during a stop operation set the DC injection braking current (07-07) and the DC injection braking time at stop (07-08) to a value greater than 0.

Notes:

- Increasing the DC braking time (07-08) can reduce the motor stop time
- Increasing the DC braking current (07-07) can reduce the motor stop time.
- During stop operation: If the DC braking start frequency < minimum output frequency (01-08), DC braking is activated when the output frequency reaches the minimum output frequency level.

07-07	DC Injection Brake Level (%)
Range	【0~ 20】 % (Frame1/2) Based on the 20% of maximum output voltage 【0~ 100】 % (Frame3/4) Based on invertor rated current

- Frame 1/2 models, please refer the formula below.
In V/F mode, the value is equal to 0~20% of max output voltage (01-01)
In SLV mode, the value is equal to 0~20% of max output voltage (02-04)
- Frame 3/4 models, the value is the equal to 0~100% of inverter rated output current.

07-08	DC Injection Brake Time (Sec)
Range	【0.0 ~ 25.5】 Sec

- 07-08/07-06 set the DC injection brake duration and the brake start frequency as shown below.

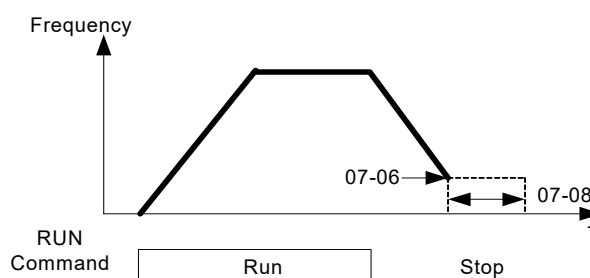

07-09	Stopping Method
Range	【0】:Deceleration to stop. 【1】:Coast to stop.

- 07-09 = 【0】 : after receiving stop command, the motor will decelerate to stop according to setting of 00-15, deceleration time 1.
- 07-09 = 【1】 : after receiving stop command, the motor will free-run (Coast) to stop.

07-10	DC Braking Level at Start
Range	【0~100】 %

- Frame 1 (1P2~1P5, 2P2~201) and Frame 2 (101, 202~203, 401~403)
In V/F mode, the value is equal to 0~20% of max output voltage (01-01)
In SLV mode, the value is equal to 0~20% of max output voltage (02-04)
- Frame 3 (205, 405~408) and Frame 4 (208~210, 410~415)
100% : the value is the equal to 0~100% of inverter rated output current.

07-11	DC Braking Time at Start
Range	【0~25.5】 s

- When DC braking time reached, output frequency will be based on V/F curve.

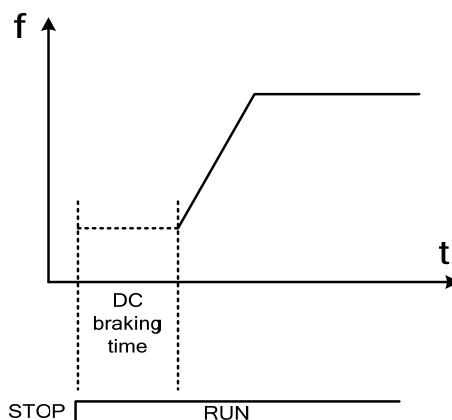

07-12	Run Command Retention
Range	0: Run command retention during power loss 1: Run command not retained during power loss

- When 07-12=0, run command during inverter run is retained before power off. After power ceclying, inverter start running automatically according to the frequency command which is retained before power off, no need to press “RUN” key again.
- When 07-12=1, run command during inverter run is not retained before power off. After power ceclying, inverter start running automatically according to the frequency command which is retained before power off, need to press “RUN” key again.
- When 14-00=0, 07-12 will be set to 1 automatically. When 14-00=1, 07-12 will be set to 0 automatically.

08- Protection function group

08- 00	Trip Prevention Selection
Range	【xxxx0】 :Enable Trip Prevention During Acceleration 【xxxx1】 :Disable Trip Prevention During Acceleration 【xxx0x】 :Enable Trip Prevention During Deceleration 【xxx1x】 :Disable Trip Prevention During Deceleration 【xx0xx】 :Enable Trip Prevention in Run Mode 【xx1xx】 :Disable Trip Prevention in Run Mode 【x0xxx】 :Enable over voltage Prevention in Run Mode 【x1xxx】 :Disable over voltage Prevention in Run Mode

08- 01	Trip Prevention Level During Acceleration
Range	【 50 ~ 200 】 %

- Trip prevention adjustment level during acceleration to prevent over current (OC-A) trips.
- If trip prevention during acceleration is enabled and an over current occurs due to the load, then the acceleration is interrupted until the over current level is dropped below the setting in 08-01 then the acceleration is resumed.

08- 02	Trip Prevention Level During Deceleration
Range	【 50 ~ 200 】 %

- Trip prevention adjustment level during deceleration to prevent over Voltage (OV-C) trips.
- If trip prevention during deceleration is enabled and an over voltage occurs during stopping due to the load, then the deceleration is interrupted until the over voltage level is dropped below the setting in 08-02 then the deceleration is resumed.

08- 03	Trip Prevention Level during continuous Run Mode
Range	【 50 ~ 200 】 %

- Trip prevention adjustment level during continuous Run to prevent over current (OC-C) trips.
- If trip prevention during continuous Run is enabled and an over current occurs due the load such as a sudden transient load, then the output frequency is reduced by decelerating to a lower speed until the over current level is dropped below the preset in 08-03, then the output frequency accelerates back to the normal running frequency.

08- 04	Over voltage Prevention Level during Run Mode
Range	200: 【 350~390 】 VDC 400: 【 700~780 】 VDC

- Over voltage prevention level can be set by parameter 08-04 when necessary. When the DC bus voltage is higher than 08-04, inverter will keep running, the output frequency will be decreased once the DC bus voltage reduced. It's the over voltage prevention function, inverter will not appear any error message.
(If the DC bus voltage higher than OV protection level, inverter will appear "OV" message)

08-05	Electronic Motor Overload Protection Operation Mode(OL1)
Range	xxxx0: Disable Electronic Motor Overload Protection xxxx1: Enable Electronic Motor Overload Protection xxx0x: Motor Overload Cold Start xxx1x: Motor Overload Hot Start xx0xx: Standard Motor xx1xx: Invertor Duty Motor (Force Vent)

Electronic Motor Overload Protection OL1 (08-05)

- When more than one motor is connected to the inverter set the Overload protection level parameter 02-01 to the total current of all motors and provide external overload relay protection for each motor.
- When using normal power supply switch, motor overload protection 08-05=xxx1x (hot start protection curve). Because whenever power is turned off, value of heat will return to default setting.
- 08-05 = xx0xx. (Standard motor Overload protection). For standard motors with integrated cooling fan when running at low speeds the heat dissipation is not very effective, consider Force vent cooling then set parameter 08-05=xx1xx for the correct overload protection.
- 08-05 = xxxx1: Enable electronic overload protection for motor according to Setting in parameter 02-01(motor rated current).
- Refer to the curve below as an example for overload protection for a standard motor. (08-05=xx0xx)

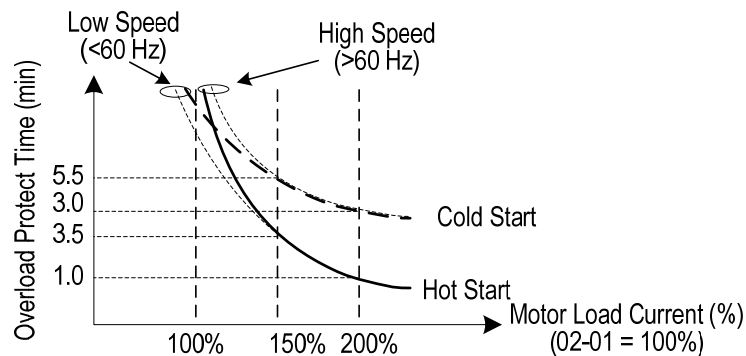

08-06	Operation After Overload Protection is Activated
Range	[0] :Coast-to-Stop After Overload Protection is Activated [1] :Drive Will Not Trip when Overload Protection is Activated (OL1)

- 08-06=0: On overload condition the inverter coast to stop as the thermal relay detects the overload and the display will flash OL1.To reset Press the 'Reset' key or use an external reset to continue to run.
- 08-06=1: On overload condition the inverter continues to run, display flash with OL1, until the current falls below the overload level.

08- 07	OH over heat Protection
Range	【0】 : Auto (Depends on heat sink temp.) 【1】 : Operate while in RUN mode 【2】 : Always Run 【3】 : Disabled

- **08-07=0:** Cooling fan runs as the inverter detects temperature rise.
- **08-07=1:** Cooling fan runs while the inverter is running.
- **08-07=2:** Cooling fan runs continuously.
- **08-07=3:** Cooling fan is disabled.

08- 08	AVR function
Range	【0】 : AVR function enable 【1】 : AVR function disable 【2】 : AVR function disable for stop 【3】 : AVR function disable for Deceleration 【4】 : AVR function disabled for stop & Deceleration from one speed to another speed. 【5】 : When VDC>(360V/740V), AVR function is disabled for stop and deceleration

- Automatic voltage regulator function provides a level of output voltage stability when there is input voltage instability. So when 08-08=0, Input voltage fluctuations will not affect the output voltage.
- 08-08=1, input voltage fluctuations will cause fluctuations on output voltage.
- 08-08=2, AVR is disabled during stopping to avoid an increase in stopping time.
- 08-08=3, AVR is disabled only during deceleration from one speed to another speed. This will avoid longer than required deceleration time.
- 08-08=4, AVR function disabled for stop & Deceleration from one speed to another speed.
- 08-08=5, when VDC>360(200V series) or VDC>740V(400V series), AVR function is disabled for stop and deceleration

08- 09	Input phase loss protection
Range	【0】 :Disabled 【1】 :Enabled

- When 08-09=1, when input phase loss detected, the warning message PF is displayed.

08- 10	PTC Motor Overheat Function
Range	【0】 : Disable 【1】 : Decelerate to stop 【2】 : Coast to stop 【3】 : Continue running, when warning level is reached. Coast to stop, when protection level is reached.
08- 11	PTC Signal Smoothing Time
Range	【0.00 ~ 10.00】 Sec
08- 12	PTC Detection Time Delay
Range	【1 ~ 300】 Sec
08- 13	PTC Protection Level
Range	【0.1 ~ 10.0】 V

08- 14	PTC Detection Level Reset
Range	【0.1 ~ 10.0】 V
08- 15	PTC Warning Level
Range	【0.1 ~ 10.0】 V

➤ **Selection for motor overheat protection:**

PTC (Positive temperature coefficient) sensors are used in motor windings to provide additional motor protection from overheat.

PTC thermistor can be connected to terminals AVI and AGND.

A voltage divider resistor R is necessary to be connected as shown below in figure (b).

- 1) If 08-10 = 1 or 2 (Decelerate or Coast to stop on over temperature detection). When over temperature is detected by signal at terminal AVI increasing above the warning detection limit set in parameter 08-15 and the delay time set in parameter 08-12 is reached, the display will show "OH4" (motor over heat detection), then output frequency will decelerate or coast to stop according to the selection 1 or 2.
- 2) If 08-10 = 3 Continue running when warning level is reached.(08-15). Coast to stop when protection level is reached.(08-13).When over temperature is detected by signal at terminal AVI increasing above the Warning detection limit set in parameter 08-15, then the display will show "OH3"(motor over heat warning level) and the motor will continue to run. If temperature detected increases above the set limit in parameter 08-13 and for the delay time set in parameter 08-12 then the display will show "OH4" (motor over heat detection), and the motor will coast to stop.
- 3) Motor over heat detection "OH4" can be reset when the temperature detection level at terminal AVI becomes lower than the set level in parameter 08-14.
- 4) External PTC thermistor characteristics

Diagram in figure (a) shows two curves for Class F and Class H temperatures.

Tr = 150°C in class F,

Tr = 180°C in class H.

Tr - 5°C: $R_{PTC} \leq 550\Omega$, put value of R_{PTC} into formula to calculate the value of V to be set in parameter 08-14.

Tr + 5°C: $R_{PTC} \geq 1330\Omega$, put value of R_{PTC} into formula to calculate, the value of V to be set in parameter 08-13.

- 5) For different specifications of PTC thermistor, set the values for parameters 08-13 and 08-14 by calculating from the formula shown below.

$$V = \frac{1}{2} \times 10 \times \frac{R_{PTC} // R_{in}}{R + (R_{PTC} // R_{in})}$$

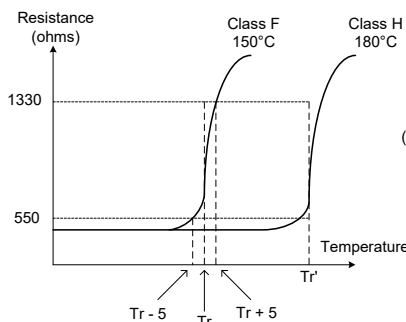

Tr : Temperature threshold value
(a) PTC Thermistor Characteristics

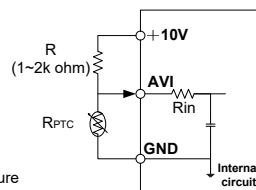

(b) PTC Thermistor Connections

**
Frame1&Frame2: Rin=164k ohm
Frame3&Frame4: Rin=204k ohm

08-16	Fan Control Temperature Level
Range	【10.0~50.0】 °C

- When 08-07=0 (Heat sink temperature detection control for cooling fan). Fan will run when temperature of heat sink is higher than 08-16; When temperature of heat sink decrease below "setting value of 08-16 minus 20°C", fan will stop.

08-17	Over current protection level
Range	【0.0~60.0】 A
08-18	Over current protection time
Range	【0.0~1500.0】 s

- When the output current exceeds the setting value of 08-17 and then keep running exceeds the setting value of 08-18, inverter will show "OL3" alarm and then stop running. (When the output current lower than the setting value of 08-17, 08-18 will be reset, over current protection function will be closed when 08-17 set to "0".)

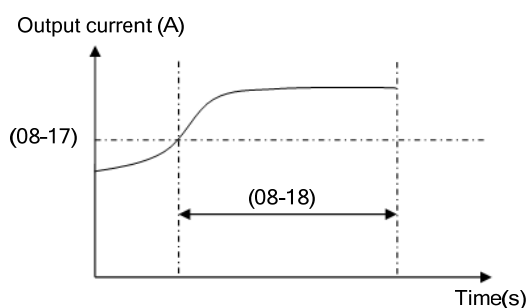

08-19	Motor Overload (OL1) Protection Level
Range	0 : Motor Overload Protection Level 0 1 : Motor Overload Protection Level 1 2 : Motor Overload Protection Level 2

Motor overload protection level (08-05)

- Set motor overload protection level according to current motor nameplate.
- Turn off the motor overload protection when using two or more motors connected to the inverter (set 08-05 = xx0b), and provide external overload protection for each motor (e.g. thermal overload switch).
- When 08-05=xx1xb (Hot start), the value of hot start will be reset once power-off.
- The motors without cooling fan (general standard motor), heat dissipation of lower speed is low, 08-05 can be set to x0xxb.
- The motors with cooling fan (special motor or V/F motor), heat dissipation is not related with output speed, 08-05 can be set to x1xxb.
- To use the built-in motor overload protection function parameter 02-01 (motor rated current) has to match the motor rated current on the motor nameplate.
- Refer to the following examples (08-05=x0xxb) and the overload curves will be based on parameter setting of 08-19.

When 08-19=0:

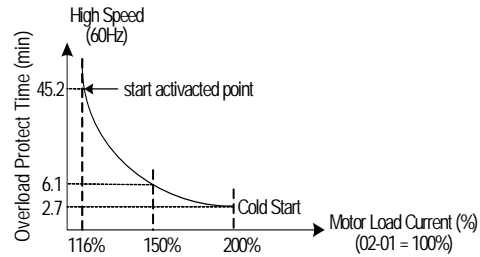
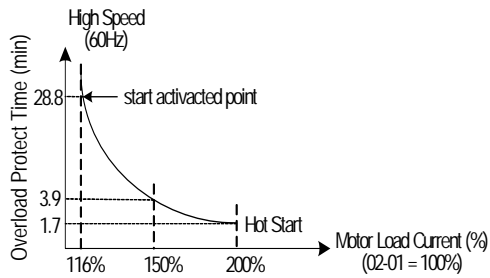
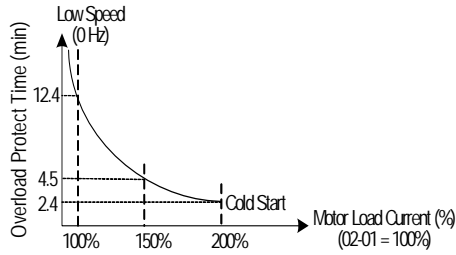
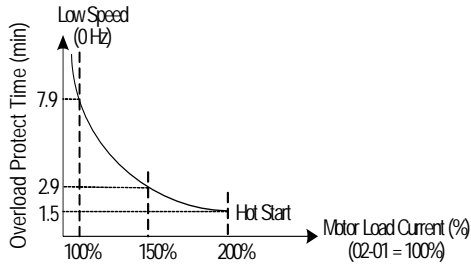

When 08-19=1:

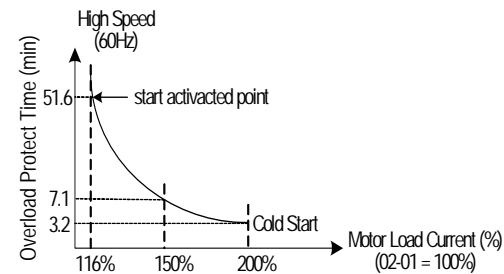
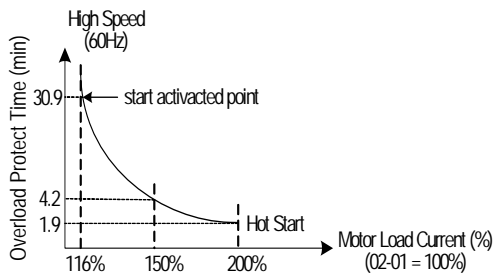
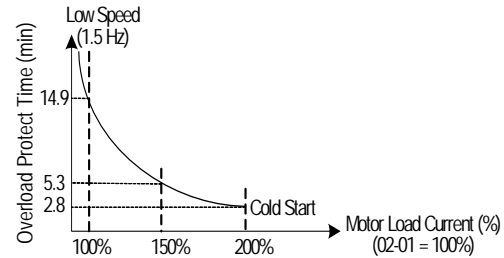
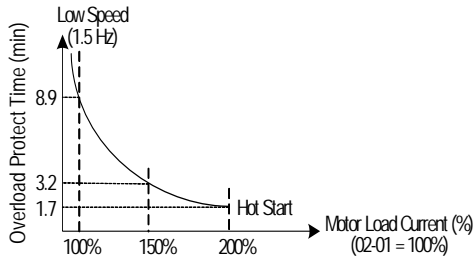

When 08-19=2:

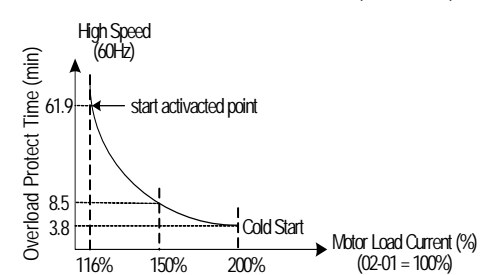
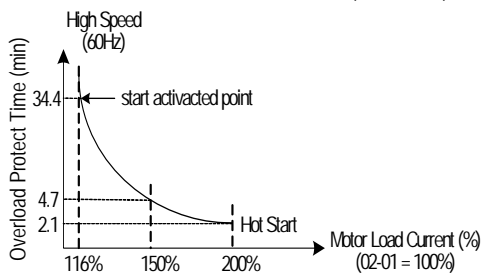
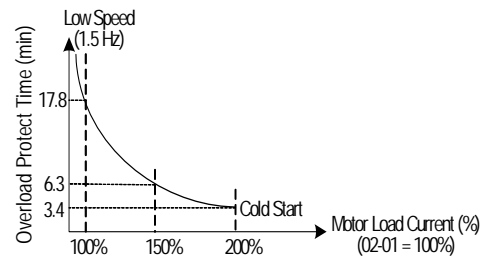
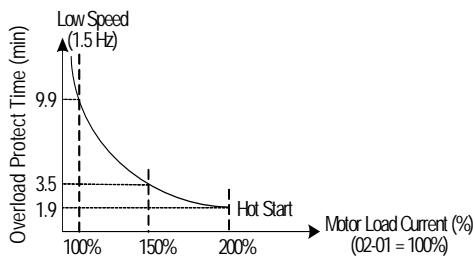

Motor overload curves (for general motor)

09- Communication function group

09- 00	Assigned Communication Station Number
Range	【 1 ~ 32】

- 09-00 sets the communication station number when there are more than one unit on the communication network. Up to 32 Slave units can be controlled from one master controller such as a PLC.

09- 01	Communication Mode Select
Range	【 0】 :RTU 【 1】 :ASCII 【 2】 :BACnet
09- 02	Baud Rate Setting (bps)
Range	【 0】 :4800 【 1】 :9600 【 2】 :19200 【 3】 :38400 【 4】 :Remote Keypad is enabled

- When 09-02=4, if JN5-OP-L01 is not connected, inverter will show "OPErr" message.
- When 09-02 is changed, please re-connect the input power again, the function keys of inverter will malfunction (except "Reset" key).
- If "OPErr" occurred, please press "Reset" key of inverter to clean the error code and then set 09-02 to 0~3.

09- 03	Stop Bit Selection
Range	【 0】 :1 stop bit 【 1】 :2 stop bit
09- 04	Parity Selection
Range	【 0】 :no parity 【 1】 :even parity 【 2】 :odd parity
09- 05	Data Format Selection
Range	【 0】 :8 bit data 【 1】 :7 bit data
09- 06	Communication time-out detection time
Range	【 0.0~25.5】 Sec

- 09-06 is against communication test messages. When a test message is not responded within the time specified by 09-06, Inverter will be stopped according to the setting of 09-07, and then appear "COT" on keypad display. Once the 09-06=0, inverter will not appear "time-out".

09- 07	Communication time-out operation selection
Range	【 0】 :Stop in deceleration time 1 and show COT after communication timeout 【 1】 :Stop in free run mode and show COT after communication timeout 【 2】 :Stop in deceleration time 2 and show COT after communication timeout 【 3】 :Keep running and show COT after communication timeout

- Time-out detection time: 00.0~25.5 seconds; setting 00.0 seconds: disables time-out function.

09-08	Err6 fault tolerance times
Range	【0~999】

- 09-08 is against real communication messages. When a real message does not pass error check, that message is resent. The number of errors for the same message are counted and accumulated and if it reaches the setting of 09-08, L510s will show Err6 and stop according to the setting of 07-09.

09-09	Drive Transmit Wait Time
Range	【5~65】 2ms

- This parameter is used to set the converter to receive data from the sending date to the beginning of the time.

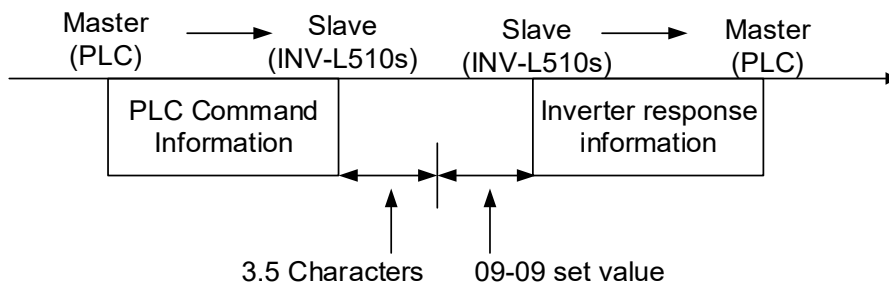

09-10	BACnet stations
Range	【1~254】

10-PID function Setup

PID block diagram

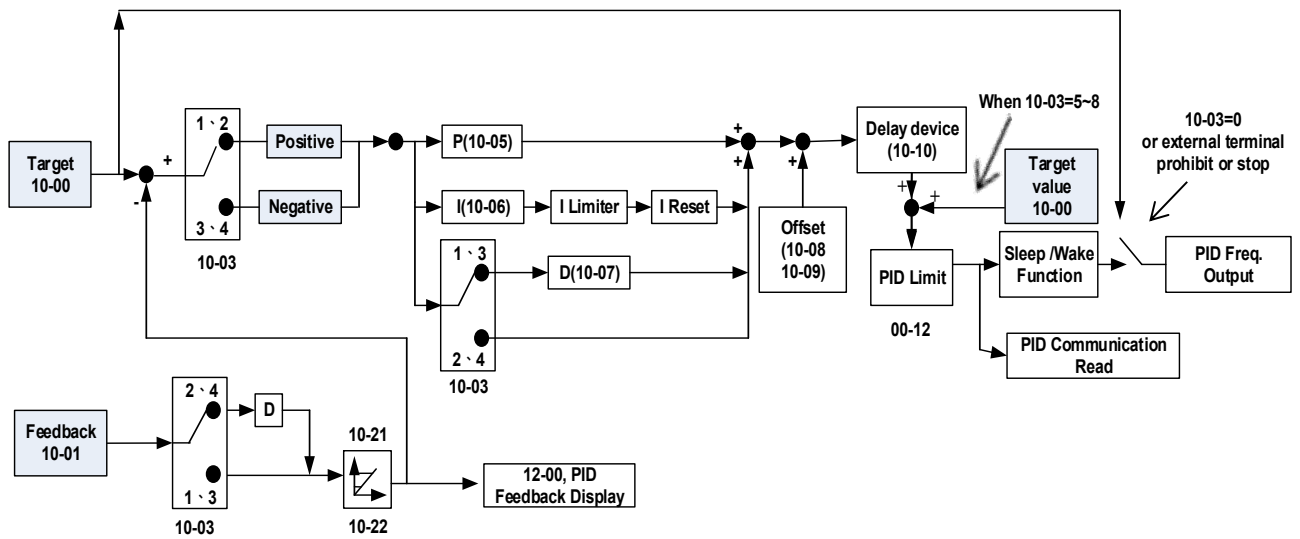

10- 00	PID target value selection
Range	[0] : Potentiometer on Keypad [1] : External AVI Analog Signal Input [2] : External ACI Analog Signal Input [3] : Target Frequency set by Communication method. [4] : Set from keypad by parameter 10-02. [5] : Set from preset frequency.

- 10-00 selections are only effective when frequency source selection is set to PID by parameters 00 - 05 / 00 - 06 = 6.
- When 10-00=5, PID target value is set according to Parameter Group 05 "preset frequency".
 Ex : When 00-05=6, 10-00=5, 10-03=1, 03-00=2, 03-01=3, 03-02=4, turn on S1~S3 sequentially (0 : OFF, 1 : ON), please check the output frequency on display is consistent with the 05-01 ~ 05-08

	S1	S2	S3
	03-00=2	03-01=3	03-02=4
Preset frequency 0 (05-01)	0	0	0
Preset frequency 1(05-02)	1	0	0
Preset frequency 2(05-03)	0	1	0
Preset frequency 3(05-04)	1	1	0
Preset frequency 4(05-05)	0	0	1
Preset frequency 5(05-06)	1	0	1
Preset frequency 6(05-07)	0	1	1
Preset frequency 7(05-08)	1	1	1

10- 01	PID feedback value selection
Range	[0] : Potentiometer on Keypad [1] : External AVI Analog Signal Input [2] : External ACI Analog Signal Input [3] : Communication setting Frequency

- ! Note: 10-00 and 10-01 can not be set to the same value.

10- 02	PID keypad input
Range	【 0.0~100.0 】 %
10- 03	PID operation selection
Range	【 0 】 : PID Function disabled 【 1 】 : FWD Characteristic. (Deviation is D-controlled) 【 2 】 : FWD Characteristic. (Feedback is D-controlled) 【 3 】 : REV Characteristic. (Deviation is D-controlled) 【 4 】 : REV Characteristic. (Feedback is D-controlled) 【 5 】 : FWD Characteristic. (Frequency Command +Deviation D Control) 【 6 】 : FWD Characteristic. (Frequency Command + Feedback D Control) 【 7 】 : Reverse characteristic. (Frequency Command + Deviation D Control) 【 8 】 : Reverse characteristic. (Frequency Command + Feedback D Control)

➤ 10-03=1

Ddeviation (target - detected value) is derivative controlled in unit time set in parameter 10-07.

➤ 10-03=2

Feedback (detected value) is derivative controlled in unit time set in parameter 10- 07.

➤ 10-03=3

Ddeviation (target value - detected value) is derivative controlled in unit time set in parameter 10- 07. If the deviation is positive, the output frequency decreases, vice versa.

➤ 10-03=4

Feedback (detected value) is derivative controlled in unit time set in parameter 10- 07.

If the deviation is positive, the output frequency decreases, vice versa.

➤ 10-03=5~8

Output frequency=PID output frequency + frequency command (10-03=1~4).

10- 04	Feedback Gain coefficient
Range	【 0.00 ~ 10.00 】

➤ 10-04 is the calibration gain. Deviation = set point – (feedback signal×10-04)

10- 05	Proportional Gain
Range	【 0.0 ~ 10.0 】

➤ 10- 05: Proportion gain for P control.

10- 06	Integral Time
Range	【 0.0 ~ 100.0 】 s

➤ 10- 06: Integration time for I control

10- 07	Derivative Time
Range	【 0.00 ~ 10.00 】 s

➤ 10- 07: Differential time for D control

10- 08	PID Offset
Range	【 0 】 : Positive Direction 【 1 】 : Negative Direction
10- 09	PID Offset Adjust
Range	【 0 ~ 109 】 %

➤ 10-08/10-09: Calculated PID output is offset by 10-09 (the polarity of offset is according to10-08)

10-10	PID Output Lag Filter Time
Range	【0.0 ~ 2.5】 s

- 10-10: Update time for output frequency.

10-11	Feedback Loss Detection Mode
Range	【0】 : Disable 【1】 : Drive keeps running After Feedback Loss 【2】 : Drive Stops After Feedback Loss

- **10-11=1: On feedback loss** detection, continue running, and display 'PDER'.
- **10-11=2: On feedback loss** detection, stop, and display 'PDER'.

10-12	Feedback Loss Detection Level
Range	【0 ~ 100】

- 10-12 is the level for signal loss. Error = (Set point – Feedback value). When the error is larger than the loss level setting, the feedback signal is considered lost.

10-13	Feedback Loss Detection Delay Time
Range	【0.0 ~25.5】 s

- 10-13: The minimum time delay before feedback signal loss is determined.

10-14	Integration Limit Value
Range	【0 ~ 109】 %

- 10-14: The Limiter to prevent the PID from saturating.

10-15	Integration Value Resets to Zero when Feedback Signal Equals the target Value
Range	【0】 : Disabled 【1】 : After 1 Sec 【30】 : After 30 Sec (Range:- 1 ~ 30 Sec)

- 10-15=0, as PID feedback value reaches the set point, the integral value will not be reset.
- 10-15=1~30, as PID feedback value reaches the set point, reset to 0 in 1~30 seconds and inverter stops. The inverter will run again when the feedback value differs from the set point value.

10-16	Allowable Integration Error Margin (Unit) (1 Unit = 1/8192)
Range	【0 ~ 100】 %

- 10-16= 0~100% unit value: Restart the tolerance after the integrator reset to 0.

10-17	PID Sleep Frequency Level
Range	【0.00~599.00】 Hz

10-18	PID Sleep Function Delay Time
Range	【0.0 ~25.5】 s

10-19	PID Wake up frequency Level
Range	【0.00 ~ 599.00】 Hz

10-20	PID Wake up function Delay Time
Range	【0.0 ~ 25.5】 s

- When PID output frequency is less than the sleep threshold frequency and exceeds the time of sleep delay, the inverter will decelerate to 0 and enters PID sleep mode.
- When PID output frequency is larger than the Wake up threshold frequency inverter will enter the PID mode again as shown in the timing diagram below.

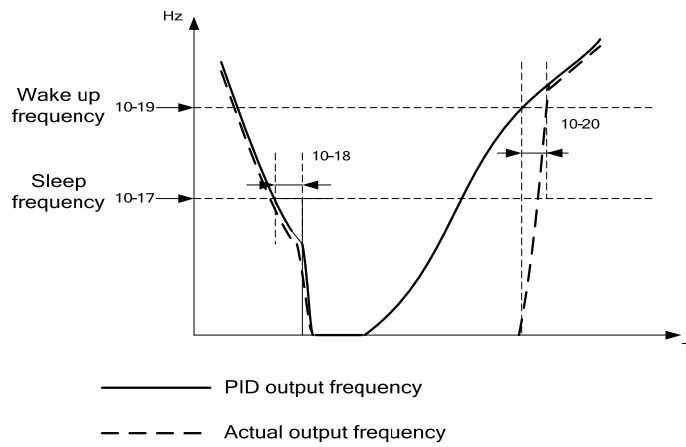

10-21	Max PID Feedback Level.
Range	【 0 ~ 999 】
10-22	Min PID Feedback Level.
Range	【 0 ~ 999 】

- Example: If 10-21=100 and 10-22=50 and the unit for the range from 0 to 999 will be defined with the parameters setting of 12-02, actual feedback value variation range, will be scaled to 50 and 100 only for display, as Shown below.

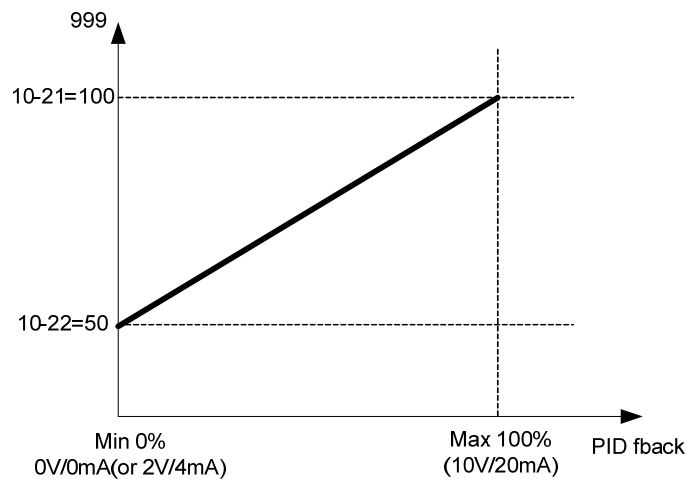

11 Performance control functions

11- 00	Prevention of Reverse operation
Range	【 0 】 :Reverse command is valid 【 1 】 :Reverse command is invalid

- When 11-00=1, inverter did not accept reverse operation command.

11- 01	Carrier Frequency
Range	【 1~16 】 KHz

- Setting range from 1 to 16 represents KHz.
- A low carrier frequency decreases RFI, EMI interference and motor leakage current.
- A low carrier frequency increases motor noise, but reduces motor losses and temperature.
- If cable length between the inverter and the motor is too long, the high-frequency leakage current will cause an increase in inverter output current, which might affect peripheral devices.

11- 02	Carrier mode selection
Range	【 0 】 :Carrier mode0 3-phase PWM modulation 【 1 】 :Carrier mode1 2-phase PWM modulation 【 2 】 :Carrier mode2 Random PWM modulation

The function can be used for audible noise reduction from a motor. It can be used in cases where the 100% torque from motor is not critical but it is necessary to reduce the audible noise.

- **Mode 0 (3-phase PWM Modulation).**

Three Output transistors are ON at the same time (Full Duty). Carrier frequency is set according to Parameter 11-01

- **Mode 1 (2-phase PWM Modulation)**

Two output transistors are ON at the same time (2/3 Duty). This mode is suitable for variable torque applications such as Fan & pump. It reduces the output transistor switching losses. Carrier frequency will be according to parameter 11-01 with the exception noted below:

- **Mode 2 (Random PWM Modulation).**

This modulation method will use 3-phase PWM and 2-phase PWM modulation in a random combination. Carrier frequency will be according to parameter 11-01

PWM mode selection considerations:

Modes	Name	IGBT Duty	Heat Losses	Torque Performance	Waveform Distortion	Motor Noise
0	3-Phase PWM	100%	High	High	Low	Low
1	2-Phase PWM	66.6%	Low	Low	High	High
2	2-Phase Random PWM	66.6%	Low	Low	High	Mid

11- 03	Carrier Frequency auto reduction due to temperature rise
Range	【 0 】 :Disable 【 1 】 :Enable

- If inverter (heat sink) temperature rises above 80°C the carrier frequency is reduced by 4K.
- If the temperature falls below less than 70°C, carrier frequency is restore to the value of **11-01**.
- Temperature can be displayed by setting parameter 12-00=04000.

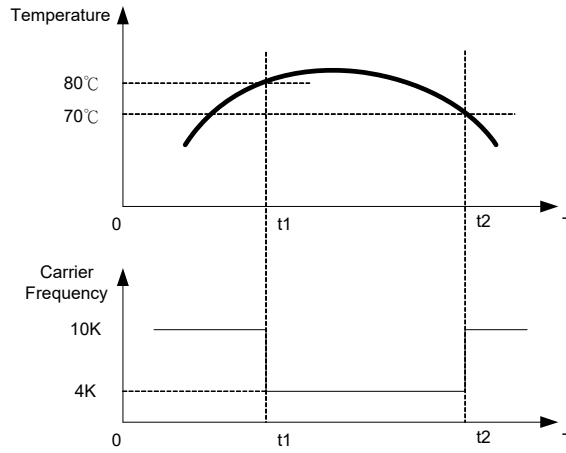

11-04	S-Curve Acc 1
11-05	S-Curve Acc 2
11-06	S-Curve Dec 3
11-07	S-Curve Dec 4
Range	【0.0 ~ 4.0】 s

- Use S Curve parameters where a smooth acceleration or deceleration action is required, this will prevent possible damage to driven machines by sudden acceleration/deceleration.

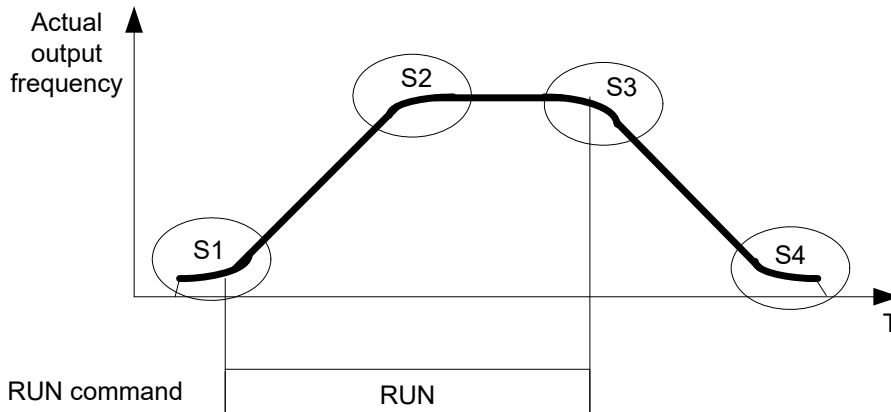

Note:

- Regardless of the stall prevention period, actual acceleration and deceleration time = preset acceleration / deceleration time + S curve time.
- Please set the required individual S curve times in the parameters (11-04~11-07).
- When S curve time (11-04~11-07) is set as 0, the S curve function is disabled.

11-08	Skip frequency 1
11-09	Skip frequency 2
11-10	Skip frequency 3
Range	【0.00 ~ 599.00】 Hz
11-11	Skip frequency range. (± frequency band)
Range	【0.00 ~ 30.00】 Hz

Skip frequency parameters can be used to avoid mechanical resonance in certain applications.
 Example: 11-08=10.00(Hz); 11-09=20.00(Hz); 11-10=30.00(Hz); 11-11=2.00(Hz).

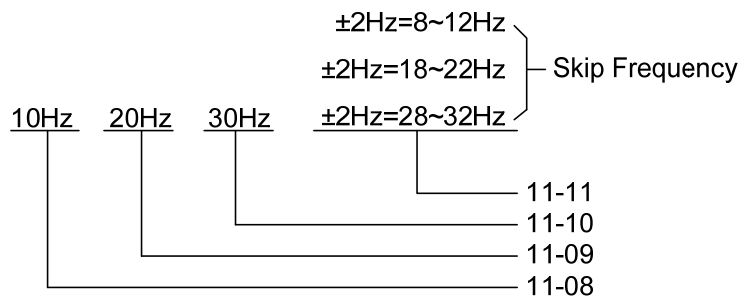

11-13	Regeneration Prevention Function
Range	【0】 : The function is disabled 【1】 : The function is enabled 【2】 : The function is enabled only during constant speed

➤ **Regeneration Prevention Function:**

During excessive energy regeneration, the Vpn (DC bus) voltage will increase and lead to OV (over voltage), to avoid over voltage due to regeneration the output frequency will be increased. Regeneration prevention function can be set according to the selections above.

Example: Regeneration prevention during acceleration.

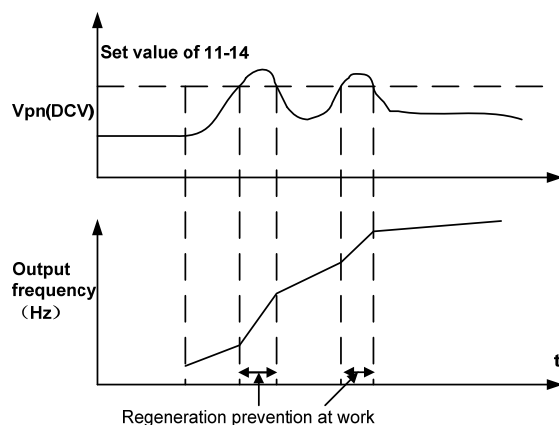

Example: Regeneration prevention during constant speed.

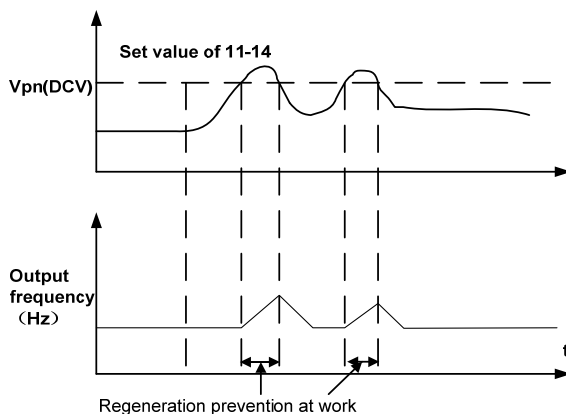

Example: Regeneration prevention during deceleration.

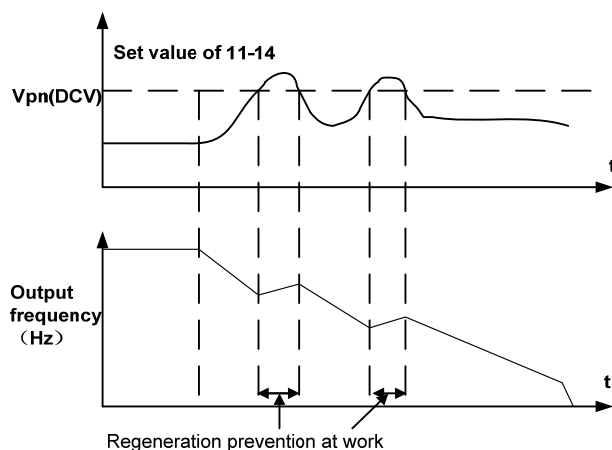

11-14	Regeneration Prevention Voltage Level
Range	200v: 300.0~400.0 V 400v: 600.0~800.0 V

- If the DC bus voltage level is set too low, then over-voltage protection will not be reached, but the actual deceleration time will be extended.

11-15	Regeneration Prevention Frequency Limit
Range	【0.00~15.00】 Hz

- Sets the regeneration prevention frequency limit.

11-16	Regeneration Prevention Voltage Gain
Range	【0~200】 %
11-17	Regeneration Prevention Frequency Gain
Range	【0~200】 %

- 11-16/11-17 represent the effect for regeneration prevention. It will enhance the response of DC bus voltage variation by enlarging the setting. However, it will lead to instability of output frequency.
- If setting 11-16 to be smaller still can't suppress the shake, please set 11-17 to be smaller.

11-18	Speed loop proportion gain
Range	【0~65535】
11-19	Speed loop integration gain
Range	【0~65535】
11-20	Speed loop differential gain
Range	【0~65535】

- SLV control mode use a output speed estimator as speed feedback value. Speed control system to adjust the output frequency to follow the value of speed feedback command. The output torque command is by the controller output with a limiter.

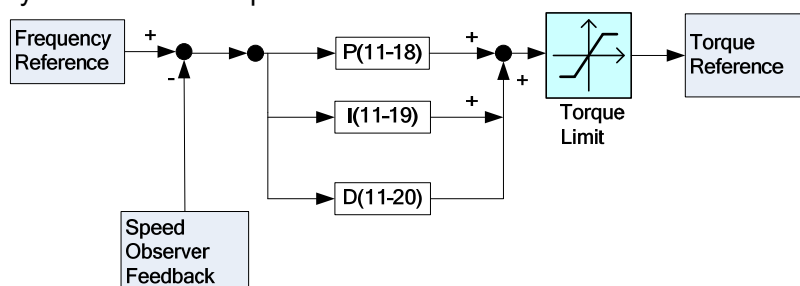

11-21	Stop Key Selection
Range	【0】 : Enable Stop Key when Run Command not from Keypad 【1】 : Disable Stop Key when Run Command not from Keypad

- When run command comes from control terminal (00-02=1) or communication (00-02=2), this parameter can be enabled or disabled the stop key function of operator.

Example 1: The following figure shows 12 - 05 display status, when S1, S3, S5 Inputs are ON and S2, S4 and RY1 are OFF.

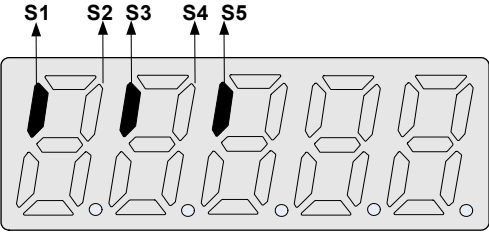

Example 2: The following figure shows 12 - 05 display status when S2, S3, S4 inputs are ON and S1, S5 are OFF but RY1 is ON.

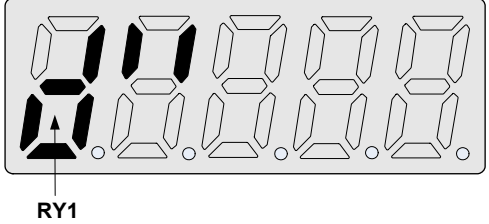

12- 06	Output Power
Range	----

- It needs to set motor rated power correctly (parameter 02-05)

12- 07	Motor Current Percentage
Range	----

- The ratio of drive output current and motor rated current, it needs to set motor rated current correctly (parameter 02-01)

13 Inspection & Maintenance functions

13- 00	Drive Horsepower Code
Range	----

Inverter Model:	13- 00 show	Inverter Model:	13- 00 show	Inverter Model:	13- 00 show
L510-1P2-SXX	1P2	L510-2P2-SXX	2P2	L510-401-SXX	401
L510-1P5-SXX	1P5	L510-2P5-SXX	2P5	L510-402-SXX	402
L510-101-SXX	101	L510-201-SXX	201	L510-403-SXX	403
		L510-202-SXX	202	L510-405-SXX	405
		L510-203-SXX	203	L510-408-SXX	408
		L510-205-SXX	205	L510-410-SXX	410
		L510-208-SXX	208	L510-415-SXX	415
		L510-210-SXX	210		

13- 01	Software Version
Range	----
13- 02	Fault Log Display (Latest 3 faults)
Range	----

- Last three faults are stored in a stack and whenever there is a new fault the previous faults are pushed down the stack. So the fault stored in 2.xxx will be transferred to 3.xxx, and the one in 1.xxx to 2.xxx. The recent fault will be stored in the empty register 1.xxx.
- Use ▲ and ▼ keys to scroll between the fault registers.
- Pressing reset key when parameter 13-02 is displayed then all three fault registers will be cleared and the display for each register will change to 1. ---, 2. ---, 3. ---.
- E.g. fault log content is '1.OC-C'; this indicates the latest fault is OC-C, etc.

13- 03	Accumulated Inverter Operation Time 1
Range	【0~23】 Hours
13- 04	Accumulated Inverter Operation Time 2
Range	【0~65535】 Days
13- 05	Accumulated Inverter Operation Time Mode
Range	【0】 :Power on time 【1】 :Operation time

- When the operation time recorded in accumulator 1(Parameter 13-03) reaches 24 hours
- The recorded value in accumulator 2 parameter 13-04 changes to 1 day and the value in accumulator 1 is reset to 0000.

13- 06	Parameter lock
Range	【0】 : Enable all Functions 【1】 : Preset speeds 05- 01~05- 08 cannot be changed 【2】 : All Functions cannot be changed Except for preset speeds set in 05- 01~05- 08 【3】 : Disable All Function Except 13-06 【4】 : Parameters 00-00 cannot be modified, cannot be restored to factory settings, other parameters can be changed

- When the 13-07=00000, you can adjust the parameters 05-01~05-08 from 13-06.

13- 07	Parameter Lock Key Code
Range	【 00000~65535】

- When parameter 13-07 is entered, all the parameters can not be modified.
For any modification, the parameter lock key code has to unlock.

Setting Parameter lock key number example:-

Step1:

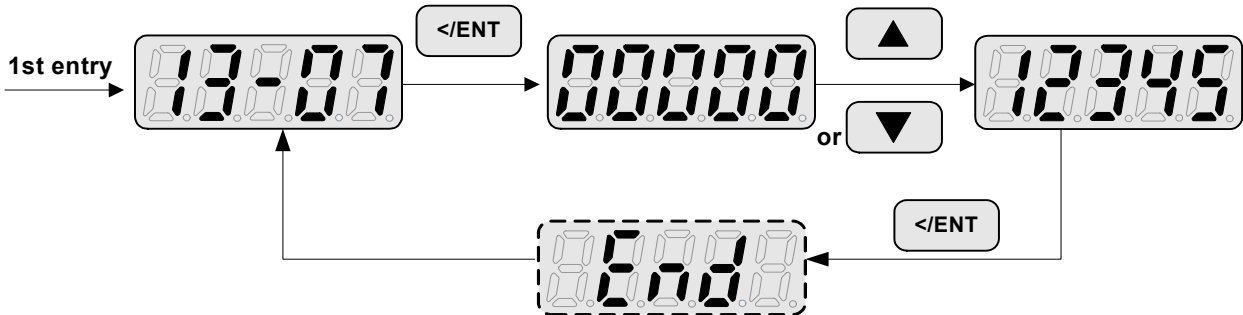

Step2:

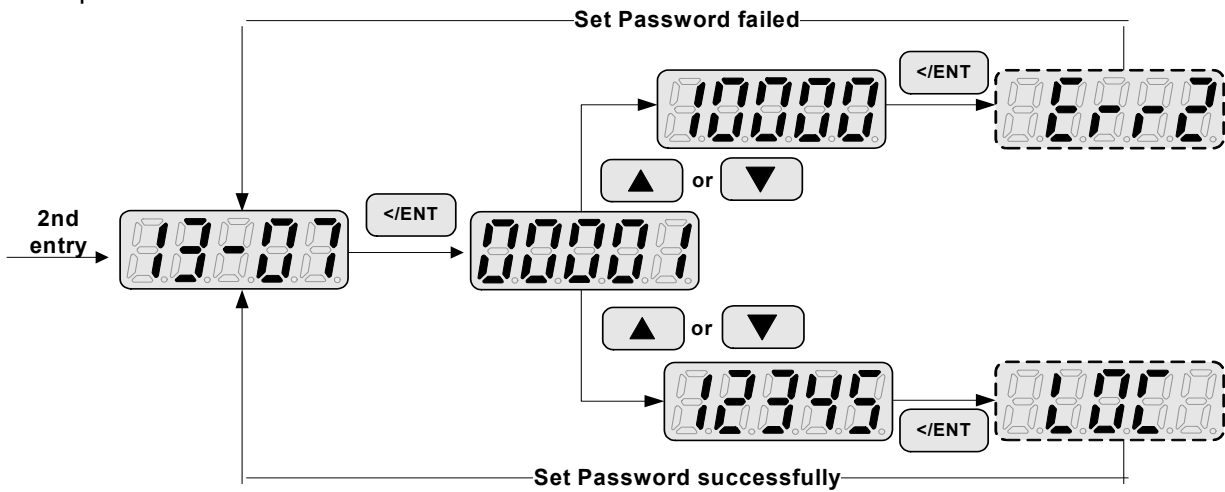

Key code (password) unlock

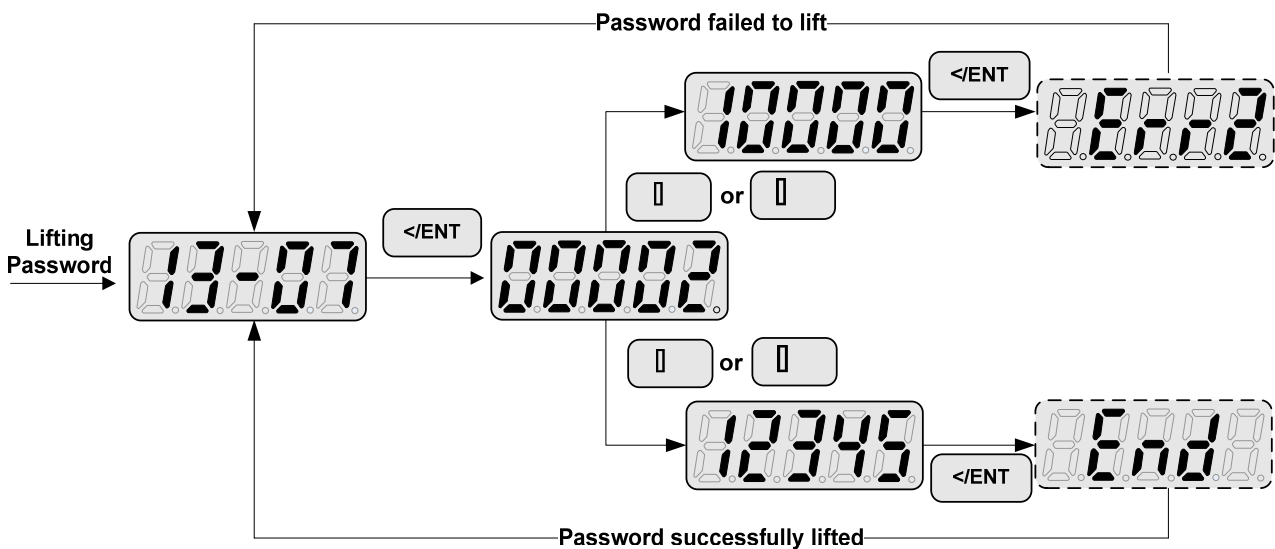

13- 08	Reset Drive to Factory Settings
Range	<p>【 1150 】 : Initialization (50Hz, 220V/380V system)</p> <p>【 1160 】 : Initialization (60Hz, 220V/380V system)</p> <p>【 1250 】 : Initialization (50Hz, 230V/400V system)</p> <p>【 1260 】 : Initialization (60Hz, 230V/460V system)</p> <p>【 1350 】 : Initialization (50Hz, 220V/415V system)</p> <p>【 1360 】 : Initialization (60Hz, 230V/400V system)</p>

- When a Parameter lock key number has been entered in parameter 13-07. This key number must be entered first before parameter 13-08 can be used.
- Reset 13-08 to default setting will reset parameter 02 group.
- For built-in EMC filter models, the default setting of 13-08 is “1250”.
For without built-in EMC filter models, the default setting of 13-08 is “1360”

Group 14 PUMP Application Function

14-00	Function Selection
Range	0: Disable 1: PUMP

- Select function of pump via parameter 14-00. This function is enabled if PID control mode (10-03) is enabled.
- When 14-00=1 and 10-03=1(PID function is enabled), PUMP function will be enabled.
- When 14-00 set to 1, 07-12 will be set to 0 at the same time. (After version 1.13)

14-01	Setting of Single & Multiple Pumps and Master & Slave Machines
Range	0: Single Pump 1: Multiple pumps-Master 2: Multiple pumps-Slave 1 3: Multiple pumps-Slave 2 4: Multiple pumps-Slave 3

- Set the inverter as the Master or Slave 1~3 via parameter 14-01. Refer chapter 3 for the functional process of dual pump start to enable multiple pumps in parallel. It is required to reconnect to write in the parameter after it is set.

14-02	Operation Pressure Setting
Range	0.1~(the value of 14-03)

- Set the pressure value depending on the pressure transmitter of pump system after setting 10-00 to 0 (keypad given). °

14-03	Maximum Pressure Setting of Pressure Transmitter
Range	[0.1~650] PSI

- Set the maximum pressure value depending on the pressure transmitter of pump system. Parameter 14-02 is limited to this maximum value.

14-04	Pump Pressure Command Source
Range	0 : Set by 14-02 1 : Set by AI

- Pressure command source is given the value set by 14-02 (Operation Pressure Setting) or AI. Refer to parameter 10-00 for the setting of AI terminal.)

14-05	Display Mode Selection
Range	0: Display of Target and Pressure Feedback (14-03<99) 1: Target Pressure Only 2: Feedback Pressure Only

- This function can have the common display of target & feedback pressure or display separately
- (1) When 14-05=0, LED keypad displays pressure setting value and pressure feedback. Two-digit in the left is the pressure value setting and two-digit in the right is the pressure feedback value in the seven-segment monitor.

20 10

(2) When 14-05=1, keypad only displays the pressure setting value.

020
00.0

(3) When 14-05=2 : LED keypad only displays the pressure feedback value.

010
01.0

Note:

If Pump mode is used LED keypad, parameter 14-03 is required to ≤ 99.0 PSI.

14-06	Proportion Gain(P)
Range	【 0.00~10.00 】
14-07	Integral Time(I)
Range	【 0.0~100.0 】 s
14-08	Differential Time(D)
Range	【 0.00~10.00 】 s

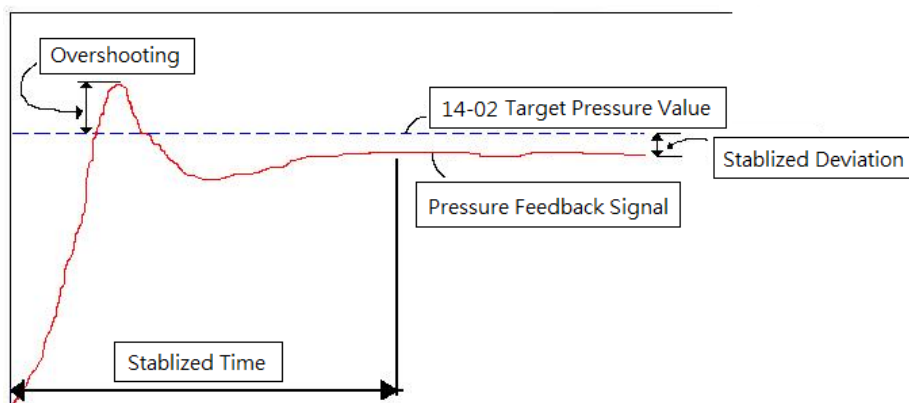
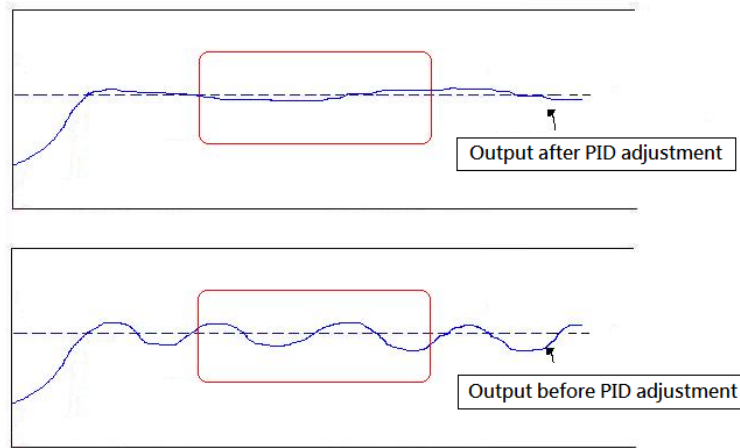

Diagram of pressure feedback value

	Increase Setting Value	Decrease Setting Value	Main Feature
Proportional Gain (P)	(Pros) Increase response time (Cons) Might cause pump jittering	(Pros) Reduce jittering (Cons) Slow down response	Increase stabilized time
Integral Time (I)	(Pros) Smooth output frequency (Cons) Slow down response	(Pros) Fast response (Cons) Change rapidly output frequency	For smooth feedback variations
Differential Time (D)	(Pros) Avoid overshooting (Cons) System instability or motor jittering	(Pros) System stability (Cons) Overshooting easily	Respond to system rapid variations

Guide for PID parameter adjustment



PID Diagram for PID parameter adjustment

* PID parameters can be modified during the inverter is running.

14-09	Tolerance Range of Constant Pressure
Range	When 14-20=0, range is 0.00~650.00 When 14-20=1, range is 0~100

- When pressure feedback value is in the range of 14-02+14-09, inverter output frequency will decrease downward into sleep status.

14-10	Sleep Frequency of Constant Pressure
Range	[0.00~599.00] Hz

- When inverter output frequency falls below 14-10 (sleep frequency of constant pressure), it starts to count the sleep time (14-11).

14-11	Sleep Time of Constant Pressure
Range	[0.00~255.5] s

- When the inverter finishes counting the sleep time (14-11), the output frequency falls downward at the deceleration time (00-15) and gets into sleep status. Parameter 14-10 (sleep frequency of constant pressure) is dedicated by the pump and it is not applied to parameter 10-17 (start frequency of PID sleep).

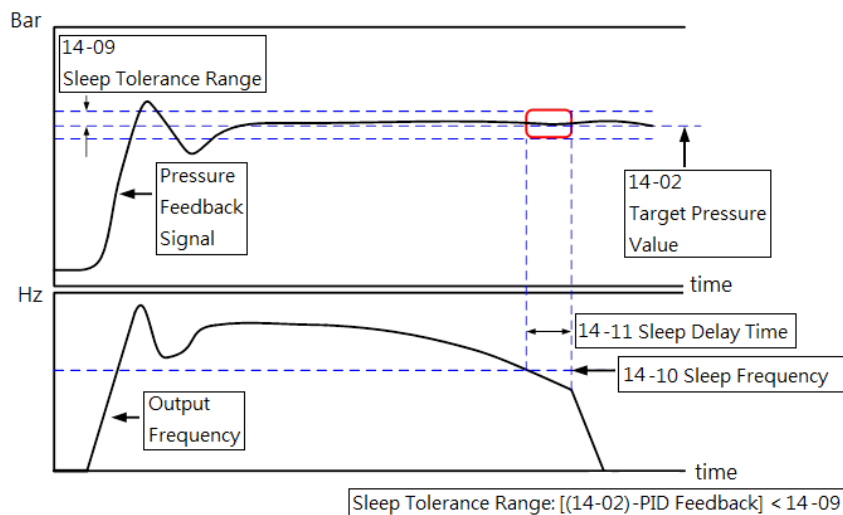

Diagram for stop time of constant pressure

14-12	Maximum Pressure Limit
Range	When 14-20=0, range is 0.00~650.00 When 14-20=1, range is 0~100

- It is convenient for user to limit maximum pressure. When pressure feedback value is higher than maximum pressure limit, the inverter displays warning signal and then stops.

14-13	Warning Time of High Pressure
Range	[0.0~600.0] s

- When pressure feedback value is higher than maximum pressure limit, warning time of high pressure starts to count. If pressure feedback value is lower than maximum pressure limit during counting time, the warning time will recount and the inverter will display the warning signal of HIPb when the warning time ends.

14-14	Stop Time of High Pressure
Range	[0.0~600.0] s

- When the warning signal of high pressure occurs and pressure feedback value is higher than maximum pressure limit, stop time of high pressure starts to count. If pressure feedback value is lower than maximum pressure limit during counting time, the stop time will recount and the inverter will display stop error signal of OPbFt when the stop time ends.

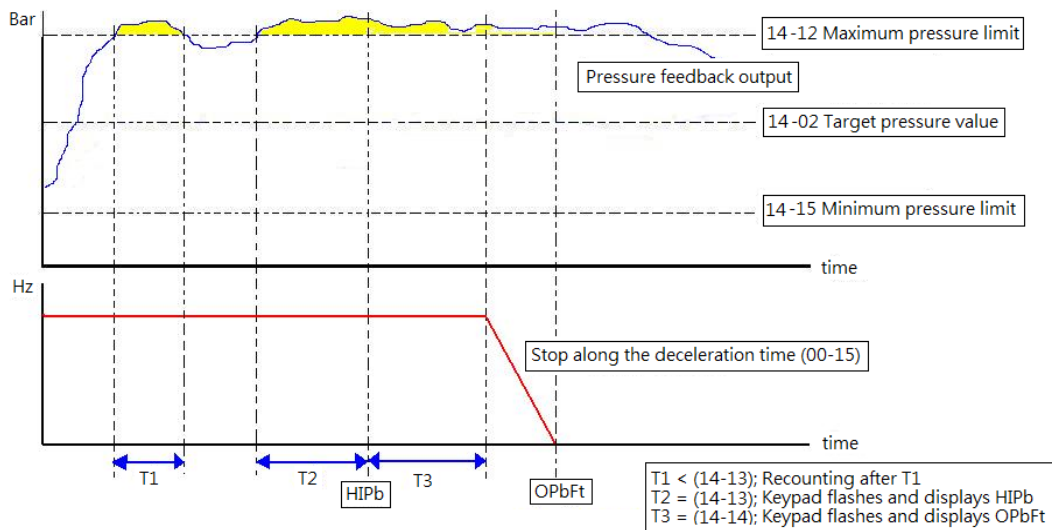

14-15	Minimum Pressure Limit
Range	When 14-20=0, range is 0.00~650.00 When 14-20=1, range is 0~100

- It is convenient for user to limit minimum pressure. When pressure feedback value is lower than minimum pressure limit, the inverter displays warning signal and then stops.

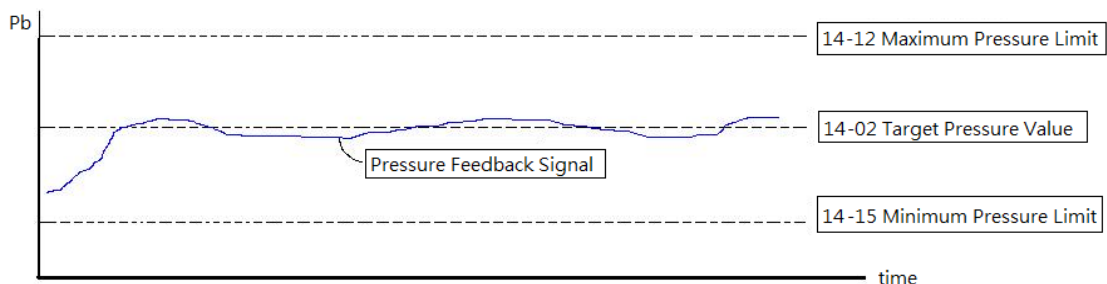

Diagram for pressure feedback limit

Note:

The pressure under the control of PID is between the maximum pressure limit (14-12) and minimum pressure limit (14-15).

14-16	Warning Time of Low Pressure
Range	【0.0~600.0】 s

- When pressure feedback value is lower than minimum pressure limit, warning time of low pressure starts to count. If pressure feedback value is higher than minimum pressure limit during counting time, the warning time will recount and the inverter will display the warning signal of LoPb when the warning time ends.

14-17	Fault Stop Time of Low Pressure
Range	【0.0~600.0】 s

- When the warning signal of low pressure occurs and pressure feedback value is lower than minimum pressure limit, stop time of low pressure starts to count. If pressure feedback value is higher than minimum pressure limit during counting time, the stop time will recount and the inverter will display stop error signal of LPbFt when the stop time ends.

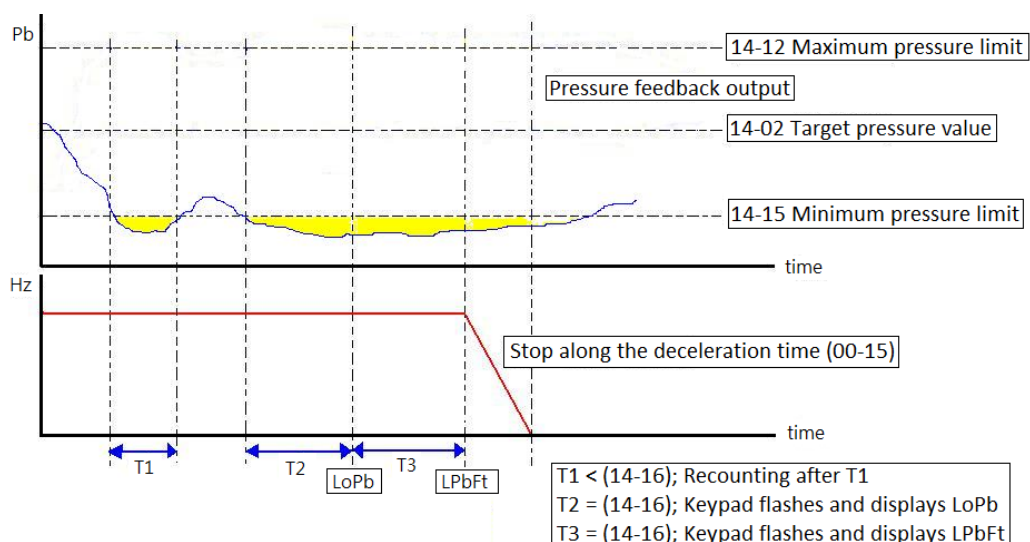

Diagram for warning to stop at low pressure limit

14-18	Time of Loss Pressure Detection
Range	【0.0~600.0】 s
14-19	Proportion of Loss Pressure Detection
Range	【0~100】 %

- When 14-19=0, function of loss pressure detection is disabled.
- When 14-19 > 0, If the feedback pressure value is lower than the value of $[(14-02) \times (14-19)]$ and the detection time of loss pressure (14-18) passes, the inverter jumps to fault signal (FBLSS).

14-20	Switching of Pressure and Percentage
Range	0: Pressure 1: Percentage

- When 14-20=0, 14-09/14-12/14-15/14-24/14-34/14-38/14-39 is displayed and set via pressure mode.
- When 14-20=1, 14-09/14-24/14-34/14-38/14-39 are proceeding to switch percentage on the basis of parameter 14-02 and parameter 14-12/14-15 are on the basis of parameter 14-03.

For example, 14-02=4.00PSI, 14-03=10.00PSI, 14-09=0.5PSI, 14-12=5.00PSI

When 14-20=0→1,

$[(14-09)/(14-02)] \times 100\% \rightarrow 14-09=13\%$ (Rounded to integer)

$[(14-15)/(14-03)] \times 100\% \rightarrow 14-15=50\%$ (Rounded to integer)

When 14-20=1→0,

$[(14-09)/100] \times (14-02) \rightarrow 14-09=0.52\text{PSI}$

$[(14-15)/100] \times (14-03) \rightarrow 14-15=5.00\text{PSI}$

14-22	Slave Trip Frequency
Range	[0.00~599.00] Hz
14-23	Direction of Water Pressure Detection
Range	0: Upward Detection 1: Downward Detection
14-24	Range of Water Pressure Detection
Range	When 14-20=0, range is 0.00~650.00 When 14-20=1, range is 0~100
14-25	Period of Water Pressure Detection
Range	[0.0~200.0] s
14-26	Acceleration Time of Water Pressure Detection
Range	[0.1~3600.0] s
14-27	Deceleration Time of Water Pressure Detection
Range	[0.1~3600.0] s

- 14-26 and 14-27 are corresponding to 00-16 and 00-17, so the setting of 14-26 changed with the setting of 00-16. Thus, avoid using multi-speed application function while using PUMP function.

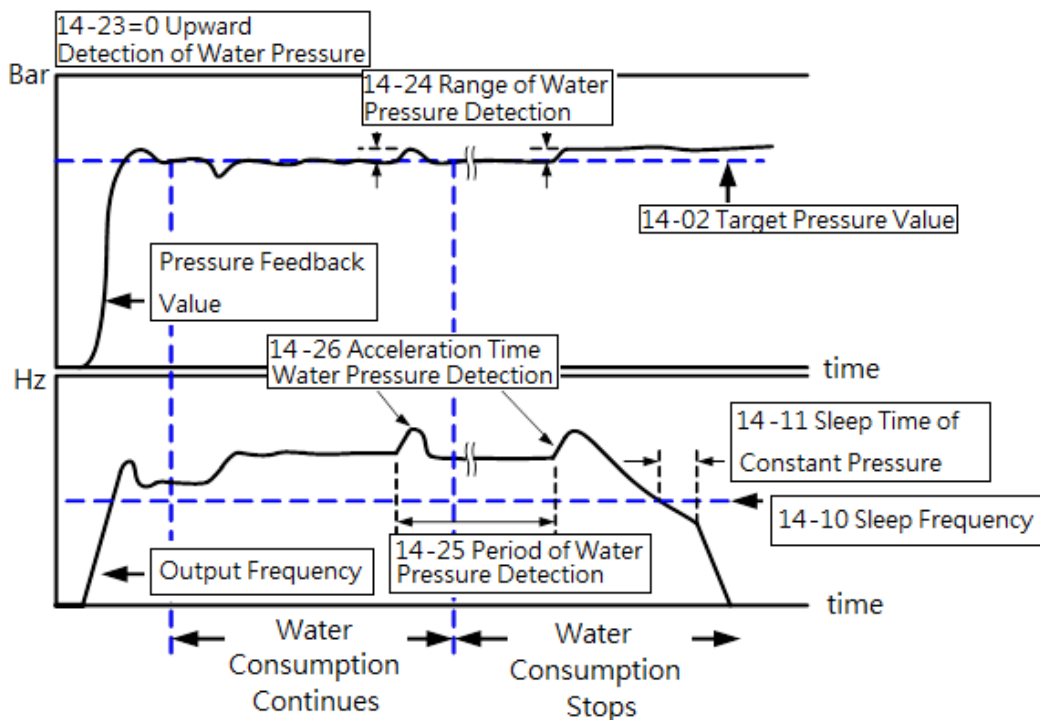

Diagram for upward detection of water pressure

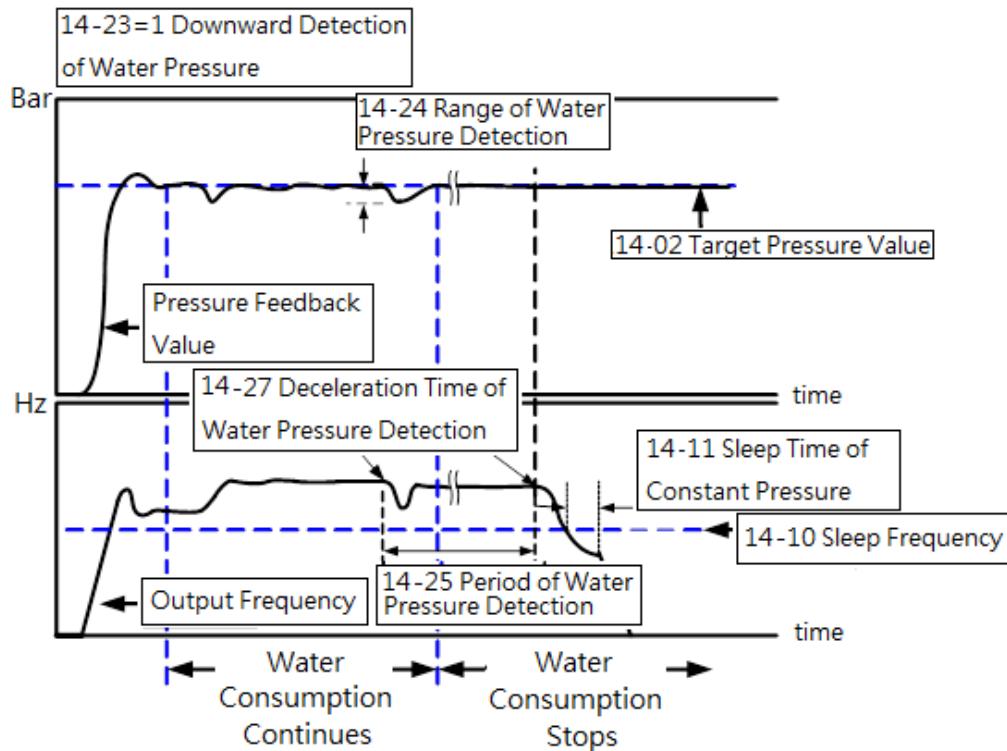

Diagram for download detection of water pressure

- When 14-25=0.0(sec) means to disable the function of water pressure detection.
- When function of water pressure detection is enabled, it can shorten the time of jumping into sleep without water consumption or with mild water consumption. °
- If water consumption frequently continues, it is recommended to extend the cycle of water pressure detection (14-25) so as the detection times can be reduced and the occurrence of fluttering or instability during water pressure detection in constant pressure can be avoided. °
- When upward detection of water pressure starts, water pressure will slightly increase. At this time, it may cause shortly pressure fluttering or instability if water consumption continues. It is recommended to reduce the range of water pressure detection (14-24) but it will extend the time of inverter jumping into sleep without water consumption or with mild water consumption.

	Pros	Cons
Upward detection of water pressure	<ul style="list-style-type: none"> ● Keep the pressure above the target pressure during this process. ● For strict and precise applications 	<ul style="list-style-type: none"> ● If “Pump lift” is too high, operation frequency is higher without water consumption or with mild water consumption. So this detection effect is too restricted to jump into sleep. ● Energy-saving of water flow is not obvious and slave is not easy to sleep under the multiple pumps in parallel.
Downward detection of water pressure	<ul style="list-style-type: none"> ● Jump into sleep status without water consumption or with mild water consumption. ● For energy-saving purpose, under the multiple pumps in parallel regulate the pumps to the optimum operation state during this process. ● Startup frequency is by Master, Slave 1, Slave 2, and Slave 3. Sleep frequency is by Slave 1, Slave 2, and Slave 3 and Master. After the switching time is allowable, alternate Master and Slave reach the average of life expectancy. 	<ul style="list-style-type: none"> ● Pressure fluctuations may occur during this process if user inappropriately regulates the range of water pressure detection (23-24) and the deceleration time of water pressure detection (23-27).

Guide for comparison of water pressure detection direction

14-28	Forced Run Command
Range	0.00~(the value of 00-12)

- This function is enabled when PID mode (10-03) is selected. Pump will not depend on the feedback to make any PID output adjustment and runs the frequency of 00-05 (Frequency command) when multi-function digital input (S1~S6) is set to 16 (PID control disable).
- And when the other digital input is set to 57(forced frequency run), inverter sets the frequency to run depending on the parameter 14-28 (forced run command). If PID function disable is removed, the inverter is controlled by PID.

14-29	Switching Time of Water Pressure Detection
Range	【0~240】 Hr

- If function of multiple pumps in parallel is enabled, the switching way is Master→Slave1→Slave2→Slave3 → Master → ... and the switching time is set via parameter 14-72.

14-30	Detection Time of Multiple Pumps in Parallel Running Start
Range	【0~30】 s

- When parameter 14-31 is set to 1 or 3, detection time of multiple pumps in parallel running start is enabled. If water pressure can not reach the error range of constant pressure and water flow time is over the detection time (14-30), Master will inform Slave of running start.

14-31	Synchronous Selection of Multiple Pumps in Parallel
Range	0: Disable 1: Pressure Setting Run/Stop 2: Pressure Setting 3: Run/Stop

- When 14-31=0: Disabled
- When 14-31=1: Set 14-01 to 1, Pressure setting and Run/ Stop command are modified by master and Slave follows Master's command. Run/Stop command from Slave can be regarded as the emergency stop command with the highest priority.
- When 14-31=2: Pressure setting is modified by Master and Slave follows Master's command to update synchronously.
- When 14-31=3: Run/ Stop command is set by Master and Slave follows Master's command. Run/Stop command from Slave can be regarded as the emergency stop command with the highest priority.

Note:

1. When Master modifies the pressure setting, it requires pressing ENTER key to modify the pressure setting of Slave.
2. When the switching time of multiple pumps in parallel (14-29) changes and reconnection, it will recount the time.

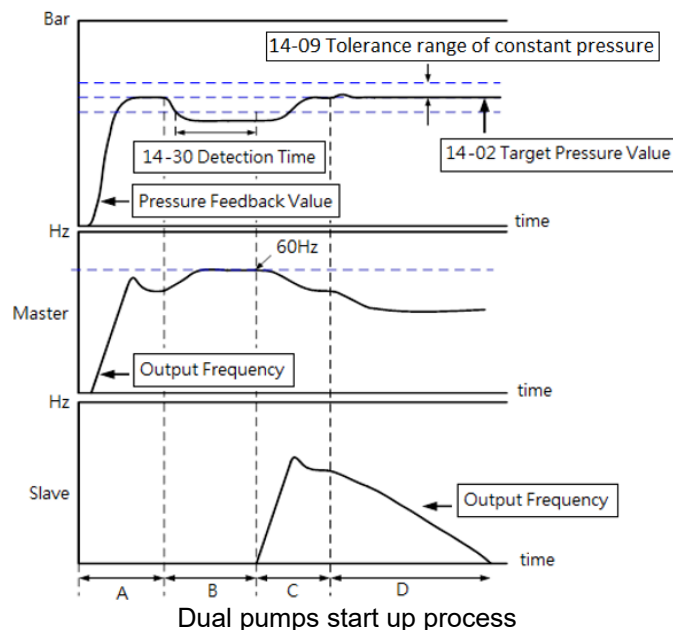

- A. Dual pumps are enabled during this time. Master starts up first and Slave is in standby to enter constant-pressure operation.
- B. Large water consumption results in the higher operation frequency of Master. If water pressure is not lower than the tolerance range of constant-pressure and the operation time is not over the detection time (14-30), Slave is still in standby.
- C. If it is over the detection time (14-30), and Master runs at 60Hz, Master informs Slave of auxiliary kicking water. After Slave operates, the operation frequency of Master and Slave reduces to the operation of constant-pressure if water consumption is stable.
- D. If water consumption is mild, the operation frequency of Master and Slave reduces. Because the water consumption is less than that of the operation of dual pumps, Slave stops to sleep (please refer to parameter 14-22 for dual pump slave sleep requirements) and only Master runs to reach constant-pressure operation.

Note :

- When 14-35=3, If the operation time is over the switching time (14-29) or sleep to stop under the operation of dual pumps, the dominance between Master and Slave will exchange to operate.
- When 14-01≠0, the parameter 14-01 of these two inverters can not be simultaneously set to 1 or 2. That is, the parameter 14-01 of one inverter is set to 1 and that of the other inverter should be set to 2 and vice versa.

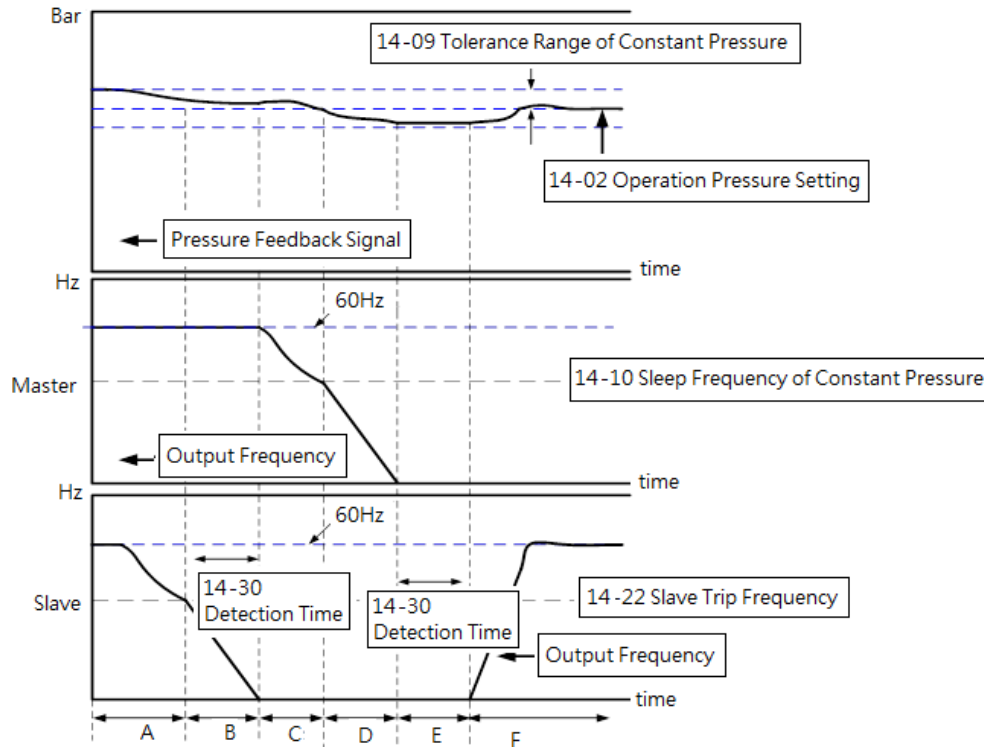

Diagram of sleep stop alternative selection action

- A. Dual pumps are enabled during this time. Higher operation pressure occurs, Master keeps operation and Slave output frequency decreases.
- B. Master operation frequency maintains 60Hz. If water pressure doesn't decrease to the target constant pressure and Slave continuously decreases to the set trip frequency (14-22), Slave detection time (14-30) starts and Slave decelerates to stop.
- C. If milder water consumption and higher water pressure occur and Slave operation command is in sleep status, Master output frequency decreases to let the water pressure be in constant status when the detection time (14-30) is over.
- D. When Master operation frequency decreases to the sleep frequency of constant pressure (23-10), Master will decrease to stop, water consumption is continuously mild and water pressure will reduce slowly. °
- E. When water consumption stops, Master jumps into sleep and the pressure remains the same, and Slave's detection time (14-30) starts.
- F. When the detection time (14-30) is over, shift operation stops and virtual Master starts to become Slave. The inverter operates in constant pressure under the target pressure value.

14-34	Tolerance Range of Constant Pressure 2
Range	When 14-20=0, range is 0.00~650.00 When 14-20=1, range is 0~100
14-35	Selection of Multiple Pumps Shift Operation
Range	0: No Function 1: Timer Alternately Selection 2: Sleep Stop Alternately Selection 3: Timer and Sleep Stop Alternately Selection 4: Multiple Pumps Test Mode

- 14-35=1, if the operation time is over the switching time (14-29) or sleep to stop under the operation of dual pumps, the dominance between Master and Slave will exchange to operate.
- 14-35=2, when the Master and Slave of multiple pumps in parallel are both in sleep mode, and after the detecting time (14-30), the Master and Slave of multiple pumps in parallel will be exchange. Every time the multiple pumps start, the exchange will be processed. Please refer to the diagram of sleep stop alternative selection action.
- 14-35=3, timer and sleep stop alternately selected will be enabled at the same time.
- 14-35=4, when master stop running and the slave need to run, no exchange between Master and Slave.

14-37	Leakage Detection Time
Range	【0.0~100.0】s
14-38	Pressure Variation of Leakage Detection Restart
Range	When 14-20=0, range is 0.00~65.00 When 14-20=1, range is 0~100
14-39	Pressure Tolerance Range of Leakage Detection Restart
Range	When 14-20=0, range is 0.00~650.00 When 14-20=1, range is 0~100

Leakage detection case 1: Pressure tolerance higher than 14-38

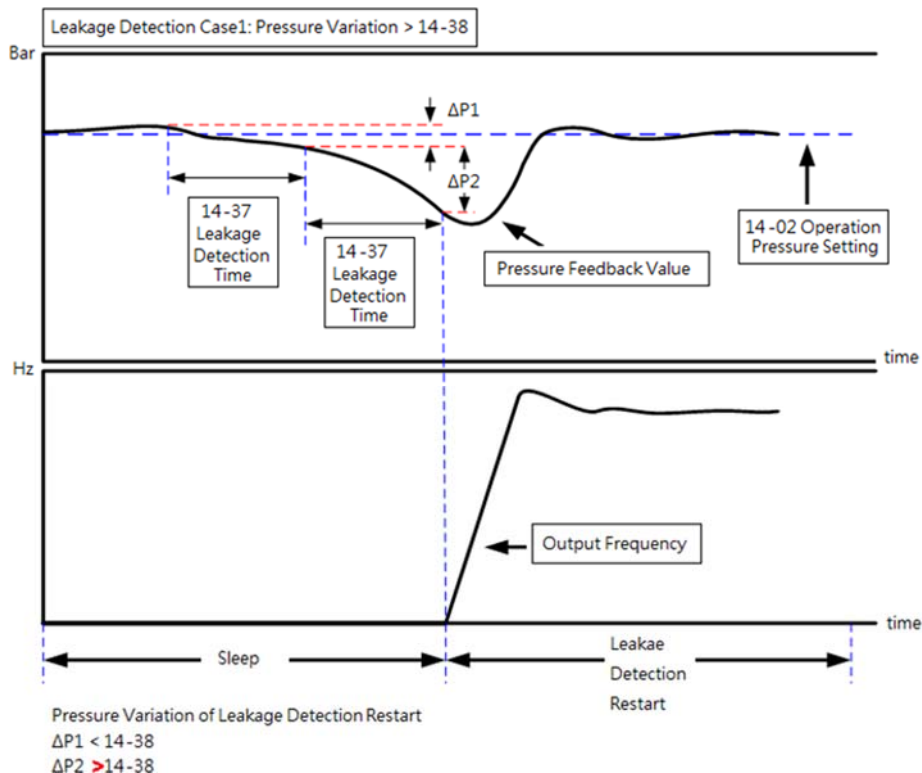

- To limit single inverter to use leakage detection.
- When 14-37 = 0.0 (sec), switch off this function.
- When pump is at shutdown state, pressure will drop over time if pipeline leaks. Pump will restart if pressure variation is larger than the value of parameter 14-38 in every detection time (14-37).

Leakage detection case 2: Pressure tolerance lower than 14-38

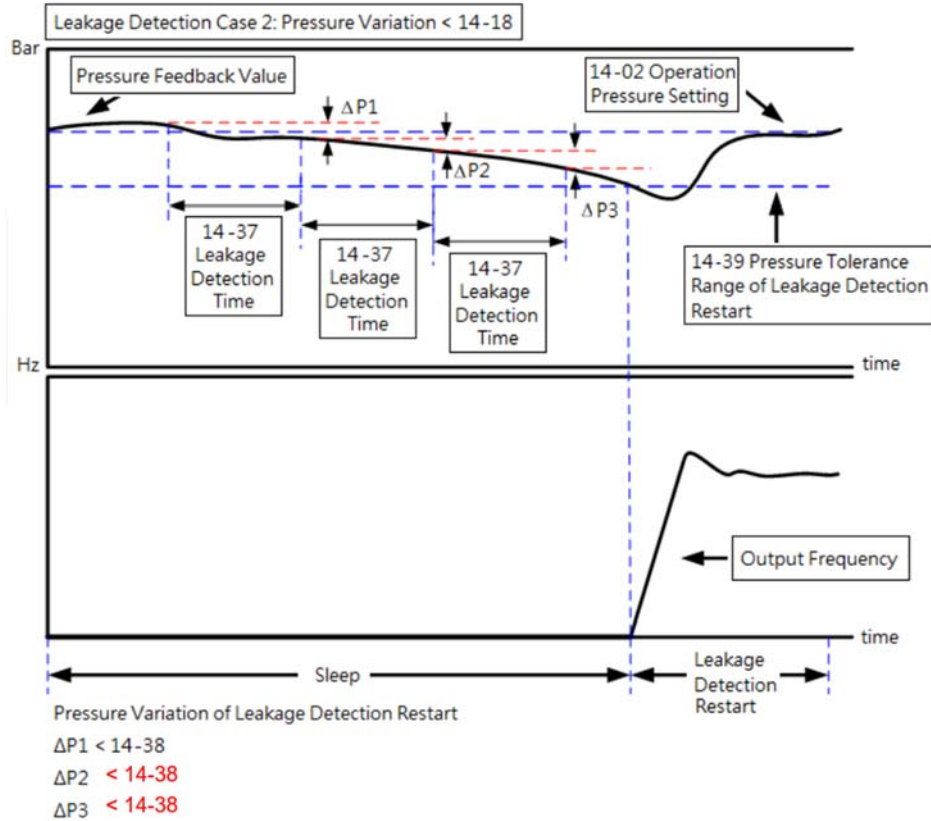

- When 14-37=0.0 (sec), switch off this function.
- When pump is at shutdown state, pressure will drop over time if pipeline leaks. Inverter will keep sleep state if pressure variation is lower than the value of parameter 14-38 in every detection time (14-37) and pump will restart if pressure variation is larger than that of 14-38 or pressure tolerance range is over the value of parameter 14-39 in the detection time. ◦
- Properly adjust the relevant leakage detection parameters 14-37, 14-38 and 14-39 to improve the condition of frequently pump start and stop caused from the dropping pressure of water system due to leakage.
- Function of leakage detection is enabled only in the setting of single pump.

14-71	Maximum Pressure Setting
Range	【0.1~650.0】PSI
14-72	Switching Time of Alternation in Parallel
Range	0: Hour 1: Minute

- When 14-72=0, parameter 14-29 will be in the unit of hour.
- When 14-72=1, parameter 14-29 will be in the unit of minute.

14-73	Slave Wake-Up Selection
Range	0: Disable 1: Enable

- When multiple pumps are in parallel and the requirements of slave wake-up can not be achieved in tolerance range, user can set parameter 14-73=1 and refer to the following conditions to wake up Slave.
- Master is in full speed operation (01-02 maximum output frequency) but pressure feedback value can not achieve the target pressure value.
- Slave is forced to start after 30secs+the value of 14-30, even if the requirement of sleep to wake-up is not achieved and the pressure feedback value is under the tolerance range of constant pressure) and keeps operation to achieve the target pressure value.
- It is required to follow the formula (the set method 1) and refer to the following diagram to set the wake-up requirements.

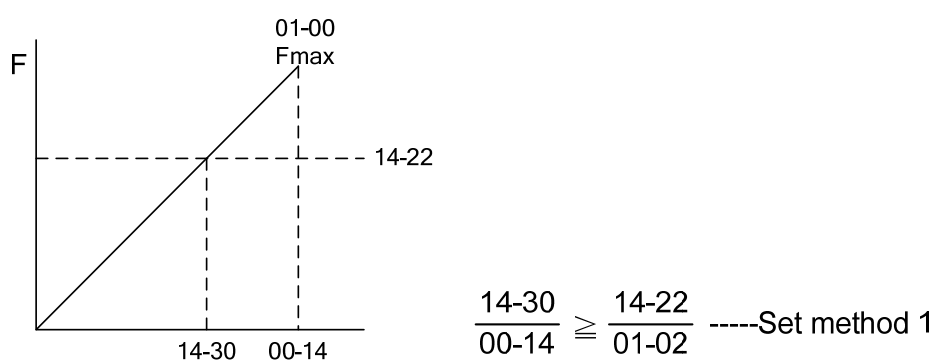

Diagram of requirements for waking up slave

14-74	Proportion Time 2 (P)
Range	0.00~10.00
14-75	Integral Time 2 (I)
Range	0.0~100.0
14-76	Differential Time 2 (D)
Range	0.00~10.00
14-77	The Value of Water Pressure Detection
Range	0~100

14-78	Maximum Current Limit
Range	0.1~6553.5
14-79	Minimum Current Limit
Range	0.1~6553.5
14-80	Current limit cumulative time
Range	0~600.0

- When 14-80=0, the current limit function is disable.
- When 14-80>0 and the output frequency is always equal to the rated frequency, if the output current is between 14-78 and 14-79, and the cumulated time exceeds 14-80, the inverter will trip the LOCu fault and stop output.
- The function of these parameters is to prevent the motor from burning when it is detected that the water pump cannot pump water.

Chapter 5 Troubleshooting and maintenance

5.1 Error display and corrective action

5.1.1 Manual Reset and Auto-Reset

Faults which cannot be recovered manually			
Display	Content	Cause	Corrective action
-OV- -OU-	Voltage too high when stopped	Detection circuit malfunction	Consult with the supplier
-LV- -LU-	Voltage too low when stopped	<ul style="list-style-type: none"> Power voltage too low Pre-charge resistor or fuse burnt out. Detection circuit malfunction 	<ul style="list-style-type: none"> Check if the power voltage is correct failed resistor or fuse Consult with the supplier
-OH- -OH-	The inverter is overheated when stopped	<ul style="list-style-type: none"> Detection circuit malfunction Ambient temperature too high or bad ventilation 	Improve the ventilation conditions, if no result then replace the inverter
OH-C OH-C	The inverter is overheated during running	<ul style="list-style-type: none"> IGBT temperature is too high or poor ventilation Temperature sensor error or circuit malfunctions 	<ul style="list-style-type: none"> Reduce carrier frequency Improve the ventilation conditions, if no result then replace the inverter
CtEr CtEr	Current Sensor detection error	Current sensor error or circuit malfunction	Consult with the supplier
HPErr HPErr	Inverter capacity setting error: Inverter capacity setting 13-00 does not match the rated voltage.	The inverter capacity setting (13-00) does not match the hardware voltage levels	Check the inverter capacity setting (13-00) to meet the hardware voltage levels.
Err4 Err4	CPU Unusual interruption	External noise interference	<ul style="list-style-type: none"> Remove the interference source then restart by switching power OFF/ON If not resolved then consult with the supplier
EPr EPr	EEPROM problem	Faulty EEPROM	Consult with the supplier
COt COt	Communication error	Communications disruption	Check the wiring

Faults which can be recovered manually and automatically

Display	Content	Cause	Corrective action
OC-A	Over-current at acceleration	<ul style="list-style-type: none"> · Acceleration time too short · The capacity of the motor exceeds the capacity of the inverter · Short circuit between the motor coil and the case · Short circuit between motor wiring and ground · IGBT module damaged 	<ul style="list-style-type: none"> · Set a longer acceleration time · Replace inverter with one that has the same rating as that of the motor · Check the motor · Check the wiring · Consult with the supplier
OC-A			
OC-C	Over-current at fixed speed	<ul style="list-style-type: none"> · Transient load change · Transient power change 	<ul style="list-style-type: none"> · Increase the capacity of the inverter · Install inductor on the power supply input side
OC-C			
OC-d	Over-current at deceleration	The preset deceleration time is too short.	Set a longer deceleration time
OC-d			
OC-S	Over current at start	<ul style="list-style-type: none"> · Short circuit between the motor coil and the case · Short circuit between motor coil and ground · IGBT module damaged 	<ul style="list-style-type: none"> · Inspect the motor · Inspect the wiring · Consult with the supplier
OC-S			
OV-C	Excessive Voltage during operation/ deceleration	<ul style="list-style-type: none"> · Deceleration time setting too short or excessive load inertia · Power voltage varies widely (fluctuates) 	<ul style="list-style-type: none"> · Set a longer deceleration time · Consider use of a brake resistor and/or brake module (For 400V models or 200V 5hp~15hp models) · Consider use of a reactor at the power input side
OV-C			
PF	Input phase Loss	Abnormal fluctuations in the main circuit voltage	<ul style="list-style-type: none"> · Check the main circuit power supply wiring. · Check the power supply voltage
PF			
LPBFT	Low pressure fault	Since feedback value of pump pressure is lower than limit of minimum flow.	<ul style="list-style-type: none"> · Check feedback signal is correct and with connection. · Check if feedback value of pressure is lower than limit of minimum pressure (14-15).
LPBFT			
OPBFT	High pressure fault	Since feedback value of pump pressure is lower than limit of maximum flow.	<ul style="list-style-type: none"> · Check feedback signal is correct. · Check if feedback value of pressure is lower than limit of maximum pressure (14-12).
OPBFT			
FBLSS	PID Feedback Signal Loss	Since proportion of loss pressure (14-19) is enabled and over high, the inverter trips to fault. Thus, feedback sensor cannot operate properly or is not installed correctly	<ul style="list-style-type: none"> · Check if the proportion of loss pressure (14-19) is set correctly · Make sure the feedback sensor is installed correctly and PID feedback signal operates normally.
FBLSS			

Faults which can be recovered manually but not automatically			
Display	Content	Cause	Corrective action
OC OC	Over-current during stop	Detection circuit malfunction	Consult with the supplier
OL1 OL1	Motor overload	loading too large	Consider increasing the Motor capacity
OL2 OL2	Inverter overload	Excessive Load	Consider increasing the inverter capacity
CL CL	Inverter over current: Wait 1 minute to reset .If it occurs CL or OL2 up to 4 successive times then wait 5 mins to reset	inverter over current warning: inverter current reach the level of over current protection	Check load condition and running period time.
LV-C LV-C	Voltage too low during operation	1. Power voltage too low 2. Power voltage varies widely (fluctuates)	1. Improve power quality 2. Consider adding a reactor at the power input side
OVSP OVSP	motor rotation over speed	The actual rotation speed is different to the set speed.	1. Check for excessive load 2. Check weather frequency setting signal is right or not
OH4 OH4	motor over heat error	1. If temperature detected increases above the set limit in parameter 08-13 and for the delay time set in parameter 08-12 then the display will show "OH4" (motor over heat detection), and the motor will coast to stop. 2. Motor over heat detection "OH4" can be reset when the temperature detection level is lower than the set level in parameter 【08-14 PTC reset level】 .	1.To improve the ventilation condition 2. Adjust parameter 08-15
OPErr OPErr	Operator setting error	When 09-02 set to 4, remote keypad (JN5-OP-L01) is disconnected.	1. Use "RESET" key of inverter to remove the error code 2. Set 09-02 to 0~3

5.1.2 Keypad Operation Error Instruction

Display	content	Cause	Corrective action
LOC	1. Parameter already Locked 2. Motor direction locked 3. Parameter password (13-07) enabled	1. Attempt to modify frequency parameter while 13-06>0. 2. Attempt to reverse direction when 11-00=1. 3. Parameter (13-07) enabled, set the correct password will show LOC.	1. Adjust 13-06 2. Adjust 11-00
Err1	Keypad operation error	1. 1.Press ▲ or ▼ while 00-05/00-06 > 0 or running at preset speed. 2. Attempt to modify the parameter can not be modified during operation (refer to the parameter list)	1. The ▲ or ▼ is available for modifying the parameter only when 00-05/00-06=0 2. Modify the parameter in STOP mode.
Err2		1. 00-13 is within the range of (11-08 ±11-11) OR (11-09 ±11-11) OR (11-10 ±11-11) 2. 00-12 ≤ 00-13 3. 10-00/10-01 set the same value 4. Modifying parameters 01-01 to 01-09 when 01-00≠7. 5. If this parameter is parameterized for both functions (AVI/PTC) at the same time ; PTC function is enabled by setting 08-10≠0; 6. Parameter password (13-07) set incorrect	1. Modify 11-08~11-10 or 11-11 2. 00-12>00-13 3. Set 00-05 / 00-06 or 10-00 / 10-01 to be different value 4. Set 01-00=7 5. PTC function source can not be the same as frequency source or PID command via AVI. 6. Please set correct password
Err5	Modification of parameter is not available in communication	1. Control command sent during communication. 2. Attempt to modify the function 09-02~ 09-05 during communication	1. Issue enable command before communication 2. Set parameters 09-02~ 09-05 function before communication
Err6		1. Wiring error 2. Communication parameter setting error. 3. Incorrect communication protocol 4. Communication ground disconnected 5. External noise	1. Check hardware and wiring 2. Check Functions(09-00~09-05). 3. CON2 needs to connect to the earth. 4. Please increase the setting value of 09-08
Err7	Parameter conflict	1. Attempt to modify the function 13-00/13-08. 2. Voltage and current detection circuit is abnormal.	If reset is not possible, please consult with the supplier.
Err7			

5.1.3 Special conditions

Display	Fault	Description
StP0 STP0	Zero speed at stop	In V/f mode, STP0 comes out at less than 1.3Hz (50Hz set) or at less than 1.5Hz (60Hz set) In SLV mode, STP0 comes out at less than 1Hz
StP1 STP1	Fail to start directly On power up.	1. If the inverter is set for external terminal control mode (00-02/00-03=1) and direct start is disabled (07-04=1) 2. The inverter cannot be started and will flash STP1. 3. The run input is active at power-up, refer to descriptions of (07-04).
StP2 STP2	Keypad Stop Operated when inverter in external Control mode.	1. If the Stop key is pressed while the inverter is set to external control mode (00-02/00-03=1) then 'STP2' flashes after stop. 2. Release and re-activate the run contact to restart the inverter.
E.S. E.S.	External Rapid stop	When external rapid stop input is activated the inverter will decelerate to stop and the display will flash with E.S. message.
b.b. b.b.	External base block	When external base block input is activated the inverter stops immediately and then the display will flash with b.b. message.
PdEr PdEr	PID feedback loss	PID feedback loss is detected.
Alter ALTER	auto tuning error	other errors show up in the process of auto tuning.
OH3 OH3	motor over heat warning	If 08-10 = 3, When over temperature is detected by signal at terminal AVI increasing above the warning detection limit set in parameter 08-15, then the display will show "OH3"(motor over heat warning level) and the motor will continue to run.
LOPB LOPB	Low pressure error	<ul style="list-style-type: none"> The feedback signal is not connected. Due to feedback value of pump pressure is lower than limit of minimum flow.
HIPB HIPB	High pressure error	Due to feedback value of pump pressure is lower than limit of maximum flow.
COPUP COPUP	Breaking error of multiple pumps communication	Communication breaking or disconnection of pump cascade control.

5.2 General troubleshooting

Status	Checking point	Remedy
Motor runs in wrong direction	Is the wiring for the output terminals correct?	Wiring must match U, V, and W terminals of the motor.
	Is the wiring for forward and reverse signals correct?	Check for correct wiring.
The motor speed can not be regulated.	Is the wiring for the analog frequency inputs correct?	Check for correct wiring.
	Is the setting of operation mode correct?	Check the Frequency Source set in parameters 00-05/00-06.
	Is the load too excessive?	Reduce the load.
Motor running speed too high or too low	Check the motor specifications (poles, voltage...) correct?	Confirm the motor specifications.
	Is the gear ratio correct?	Confirm the gear ratio.
	Is the setting of the highest output frequency correct?	Confirm the highest output frequency
Motor speed varies unusually	Is the load too excessive?	Reduce the load.
	Does the load vary excessively?	<ol style="list-style-type: none"> 1. Minimize the variation of the load. 2. Consider increasing the capacities of the inverter and the motor.
	Is the input power unstable or is there a phase loss ?	<ol style="list-style-type: none"> 1. Consider adding an AC reactor at the power input side if using single-phase power. 2. Check wiring if using three-phase power
Motor can not run	Is the power connected to the correct L1, L2, and L3 terminals? Is the charging indicator lit ?	<ol style="list-style-type: none"> 1. Is the power applied? 2. Turn the power OFF and then ON again. 3. Make sure the power voltage is correct. 4. Make sure screws are secured firmly.
	Is there voltage across the output terminals T1, T2, and T3?	Turn the power OFF and then ON again.
	Is overload causing the motor to stall?	Reduce the load so the motor will run.
	Are there any abnormalities in the inverter?	See error descriptions to check wiring and correct if necessary.
	Is there a forward or reverse run command ?	
	Has the analog frequency signal been input?	<ol style="list-style-type: none"> 1. Is analog frequency input signal wiring correct? 2. Is voltage of frequency input correct?
	Is the operation mode setting correct?	Operate through the digital keypad

5.3 Troubleshooting of the Inverter

5.3.1 Quick troubleshooting of the Inverter

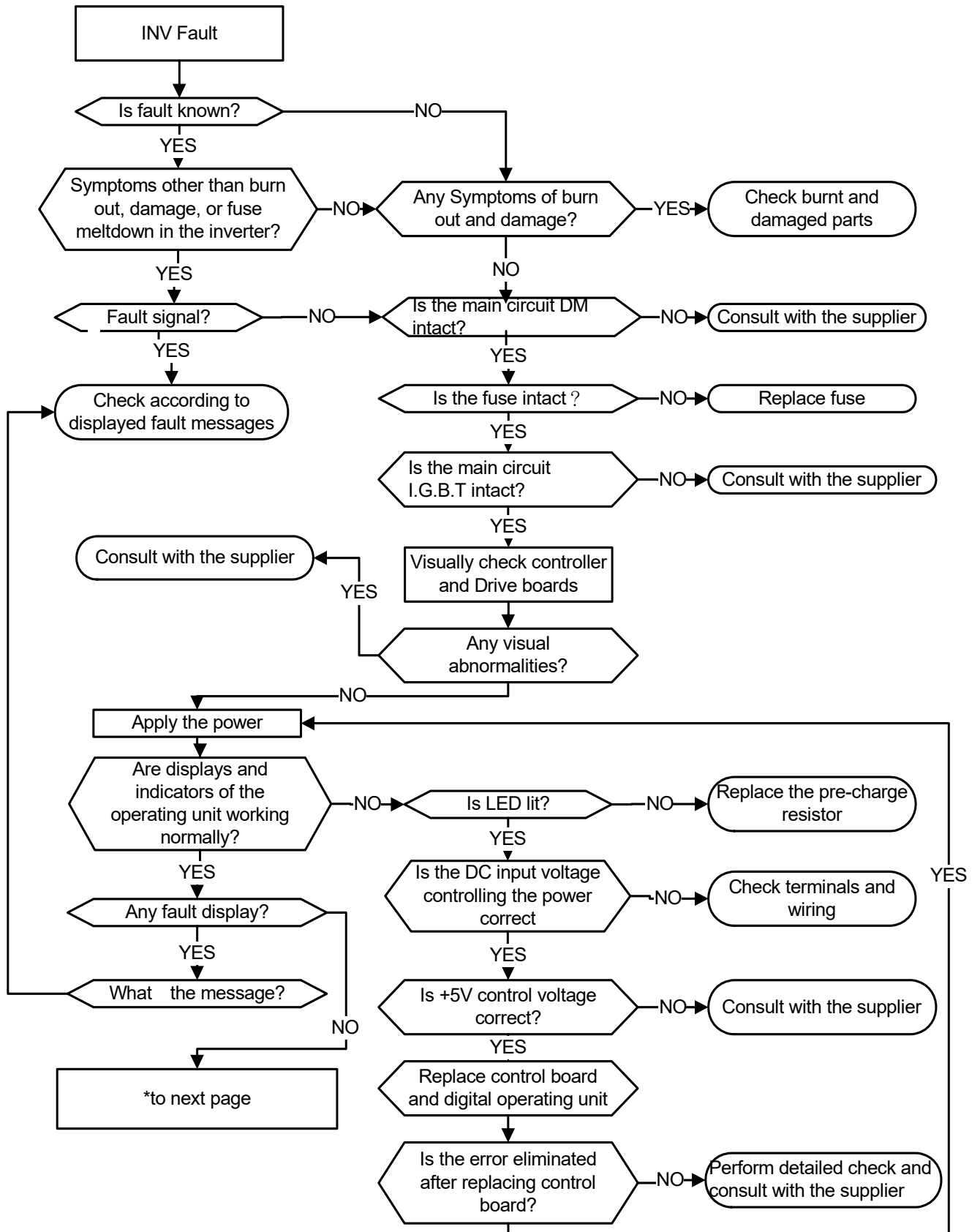

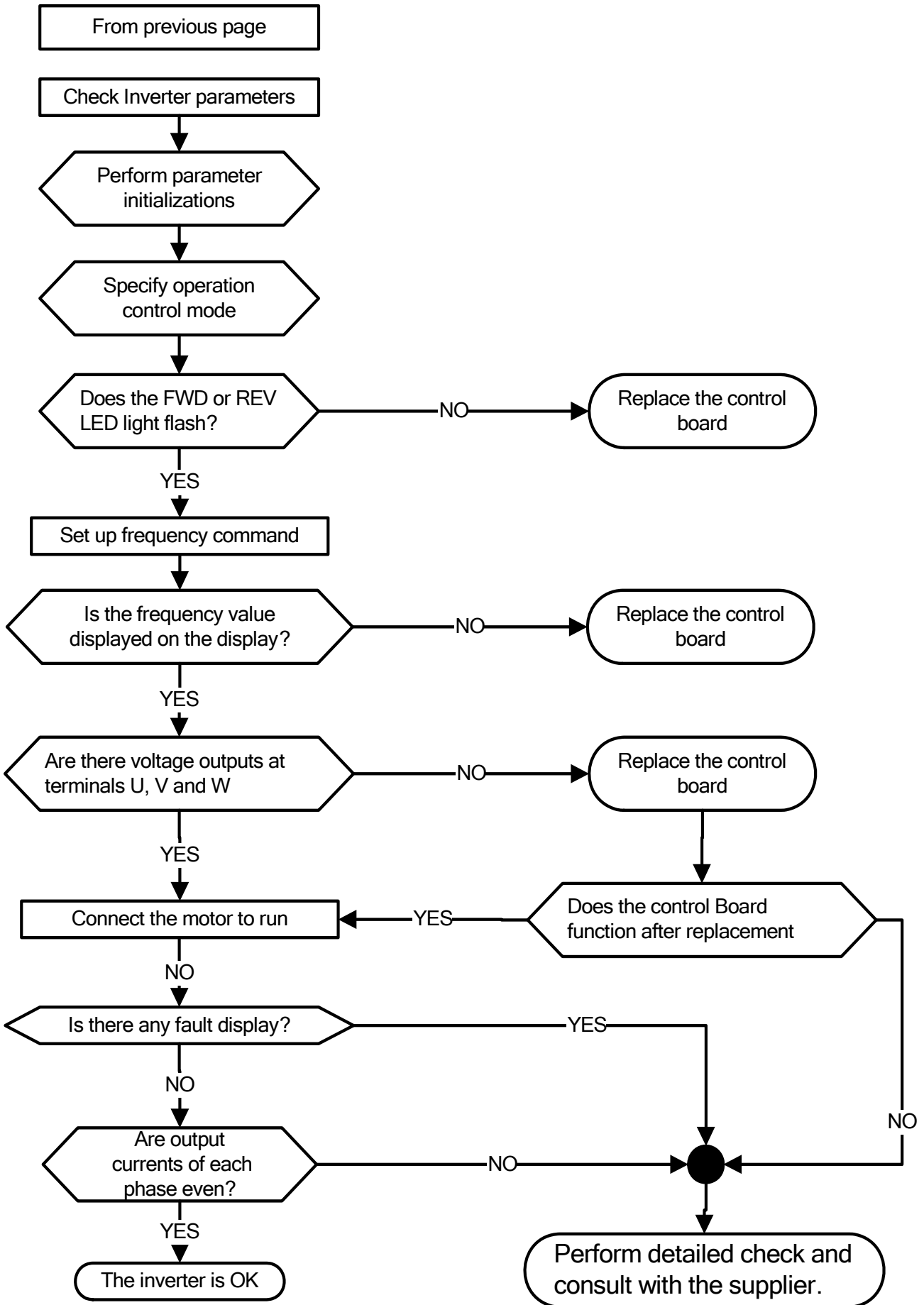

5.3.2 Troubleshooting for OC, OL error displays

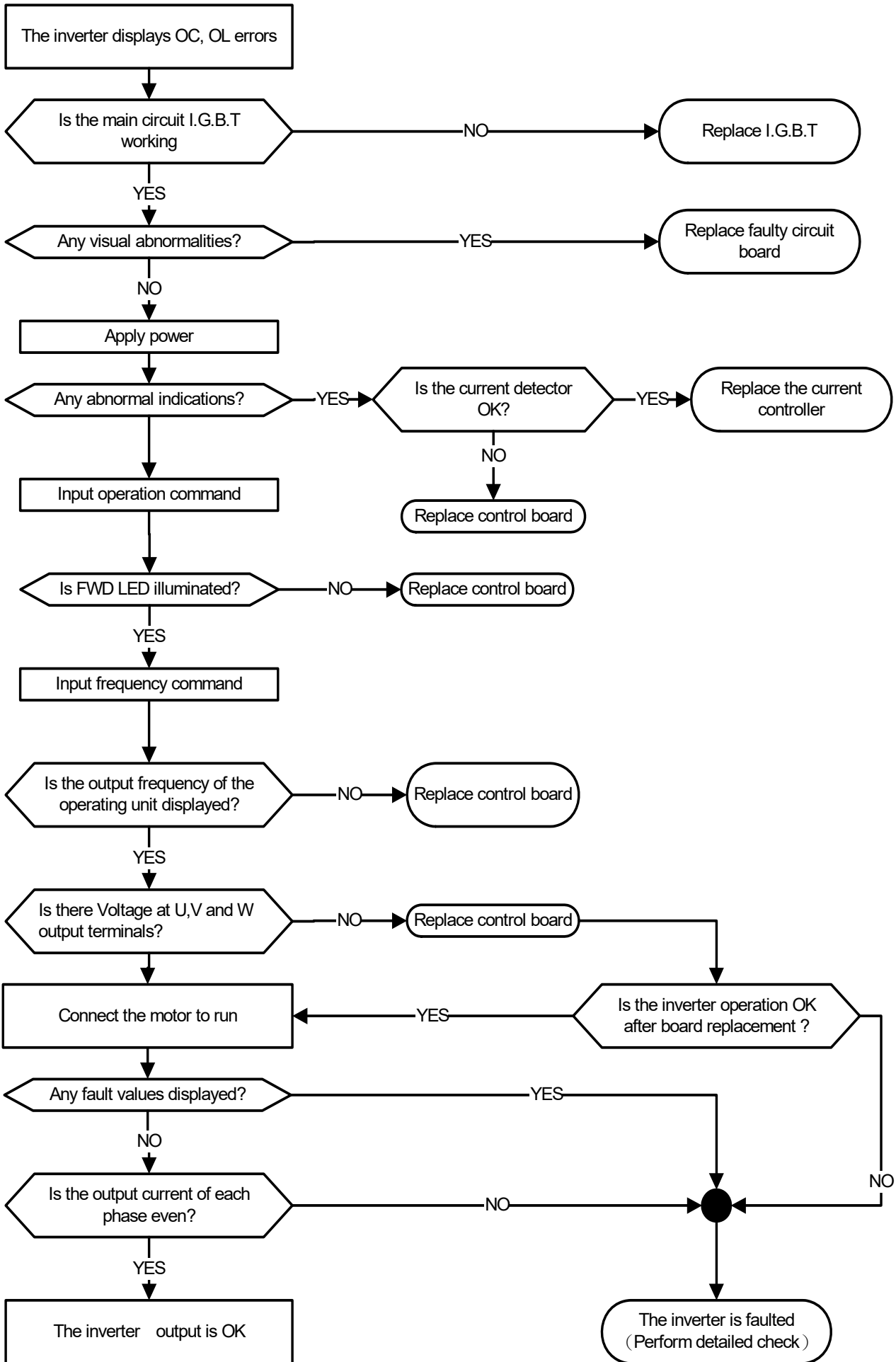

5.3.3 Troubleshooting for OV, LV error

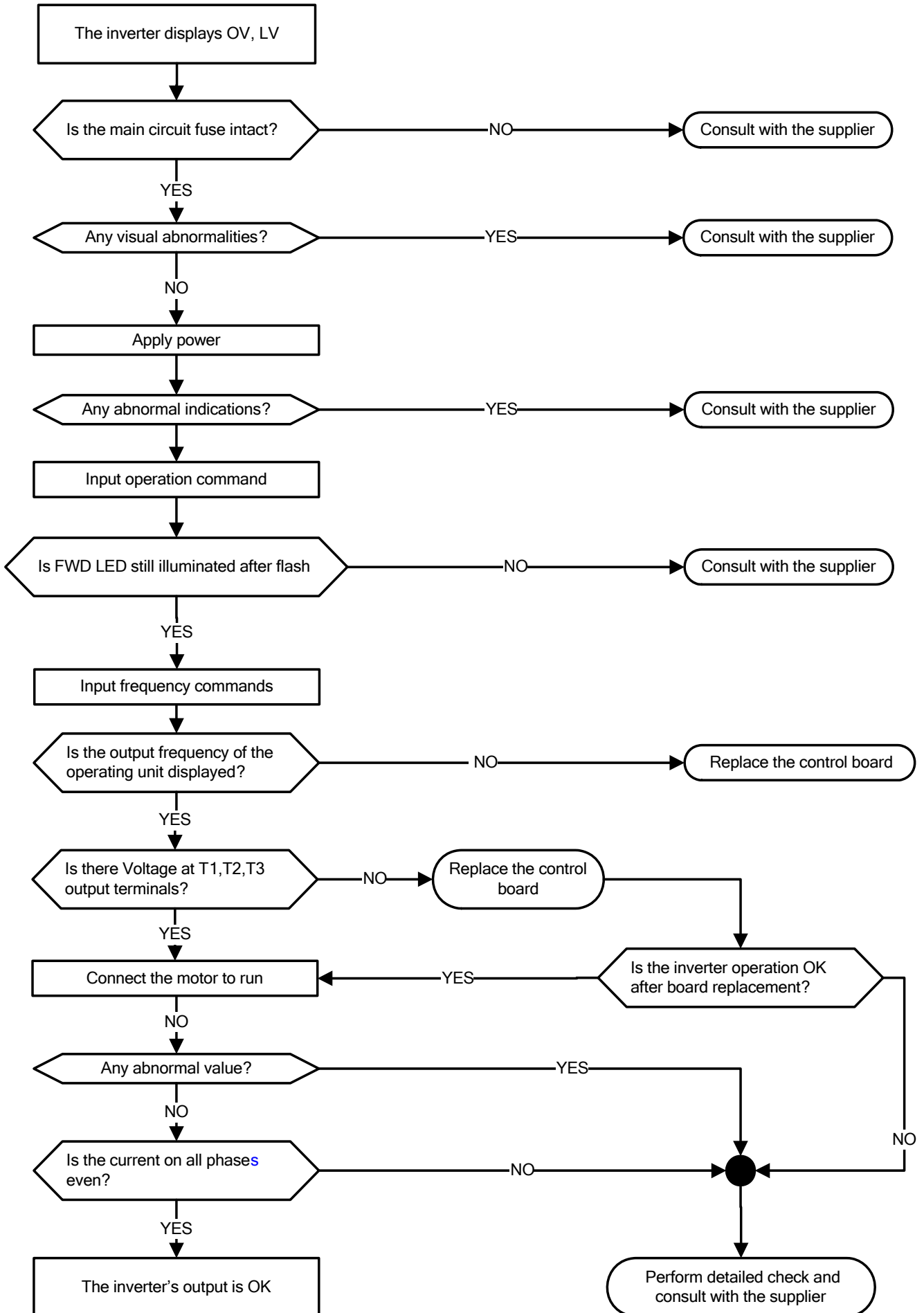

5.3.4 The motor can not run

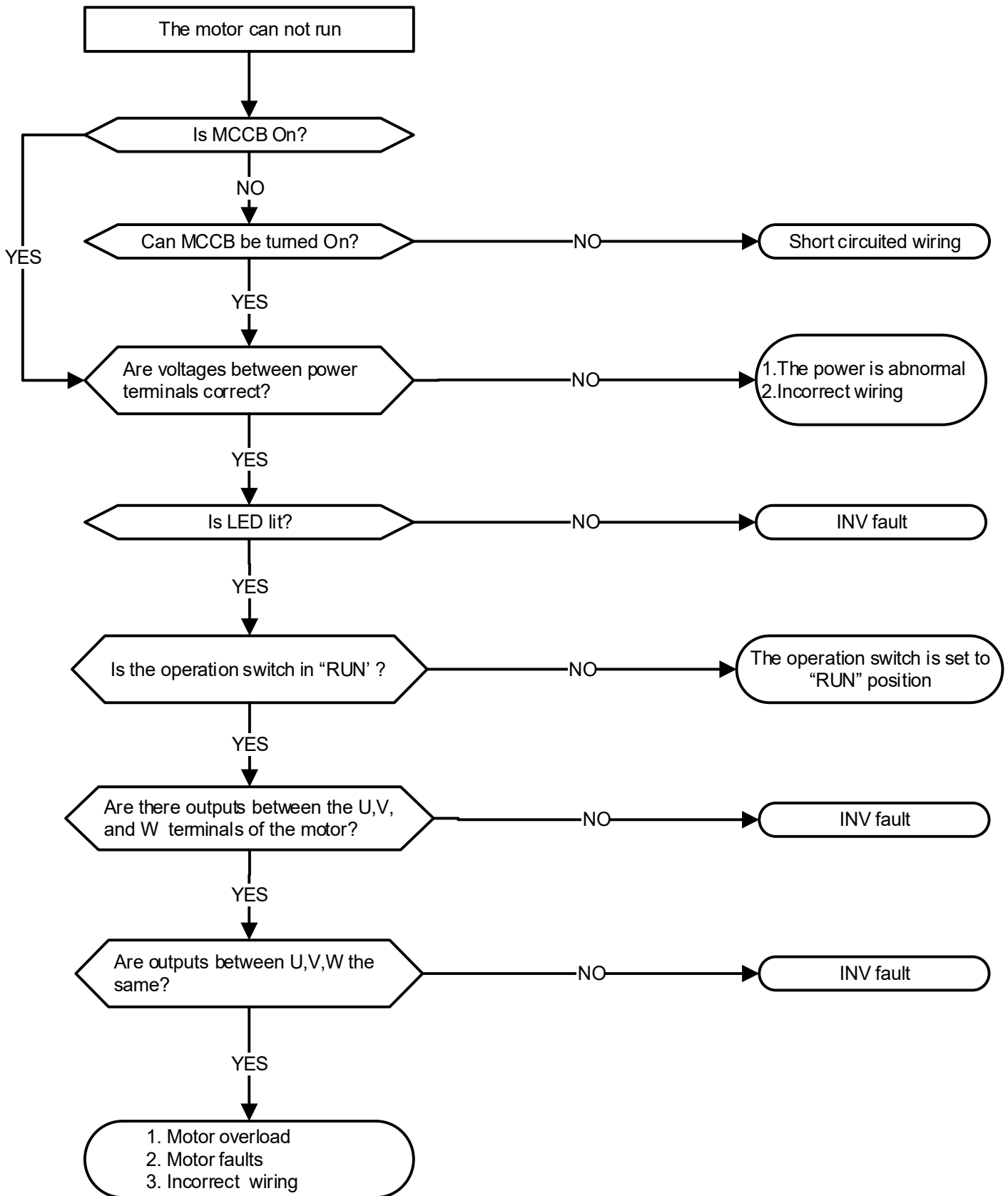

5.3.5 Motor Overheating

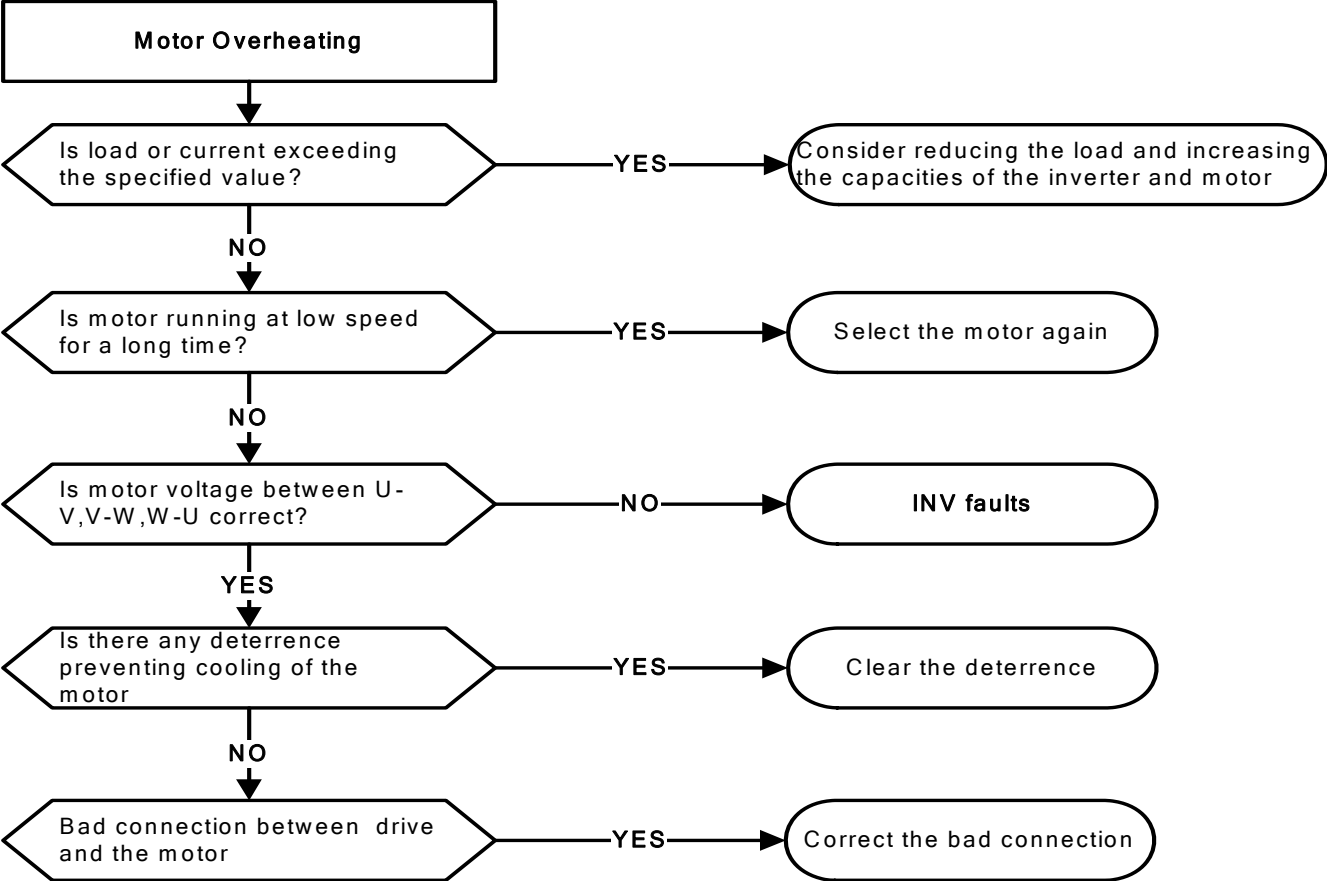

5.3.6 Motor runs unbalanced

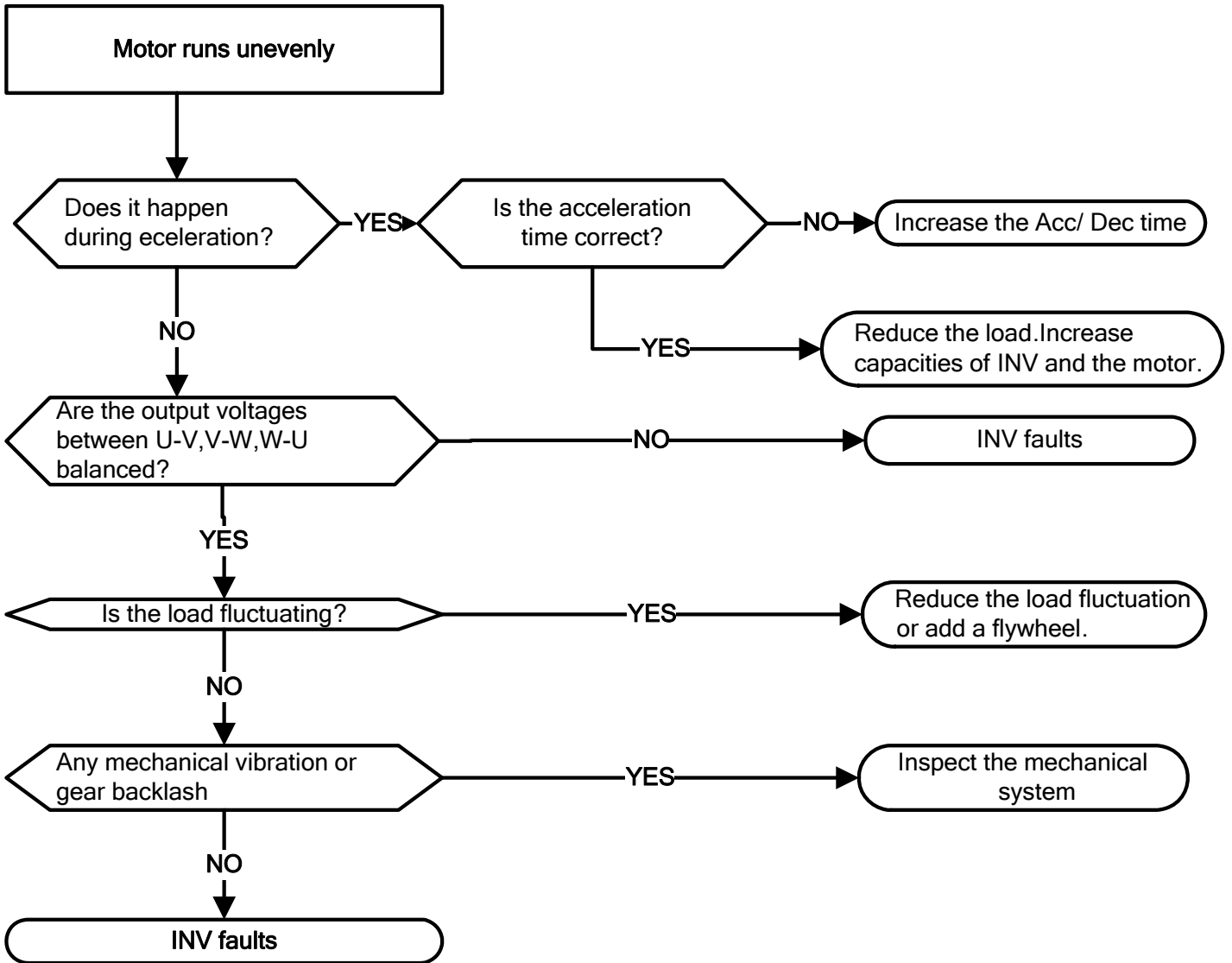

5.4 Routine and periodic inspection

To ensure stable and safe operations, check and maintain the inverter at regular intervals.

Use the checklist below to carry out inspection.

Disconnect power after approximately 5 minutes to make sure no voltage is present on the output terminals before any inspection or maintenance.

Items	Details	Checking period		Methods	Criteria	Remedies
		Daily	1Year			
Environment & Ground connection						
Ambient conditions at the installation	Confirm the temperature and humidity at the machine	☉		Measure with thermometer and hygrometer	Temperature: -10 ~40°C (14~120°F) Humidity: Below 95%RH	Improve the ambient or relocate the drive to a better area.
Installation Grounding	Is the grounding resistance correct?		☉	Measure the resistance with a multi-tester	200Vclass: below 100Ω	Improve the grounding if needed.
Terminals & Wiring						
Connection terminals	Any loose parts or terminals?		☉	Visual check Check with a screwdriver	Correct installation requirement	Secure terminals and remove rust
	Any damage to the base ?		☉			
	Any corroded Terminals?		☉			
Wiring	Any broken wires?		☉	Visual check	Correct wiring requirement	Rectify as necessary
	Any damage to the wire insulation?		☉			
voltage						
Input power voltage	Is the voltage of the main circuit correct?	☉		Measure the voltage with a multi-tester	Voltage must conform with the spec.	Improve input voltage if necessary.
Circuit boards and components						
Printed circuit board	Any contamination or damage to printed circuit board?		☉	Visual check	Correct component condition	Clean or replace the circuit board
Power component	Any dust or debris		☉			Clean components
		Check resistance between terminals		☉	Measure with a multi-tester	No short circuit or broken circuit in three phase output
Cooling System						
Cooling fan	Unusual vibration and noise?		☉	Visual and sound check	Correct cooling	Consult with the supplier
	Excessive dust or debris	☉		Visual check		Clean the fan
Heat sink	Excessive dust or debris	☉				Clean up debris or dust
Ventilation Path	Is the ventilation path blocked?	☉				Clear the path

5.5 Maintenance

To ensure long-term reliability, follow the instructions below to perform regular inspection. Turn the power off and wait for a minimum of 5 minutes before inspection to avoid potential shock hazard from the charge stored in high-capacity capacitors.

Maintenance Check List.

- Ensure that temperature and humidity around the inverters is as required in the instruction manual, installed away from any sources of heat and the correct ventilation is provided..
- For replacement of a failed or damaged inverter consult with the local supplier.
- Ensure that the installation area is free from dust and any other contamination.
- Check and ensure that the ground connections are secure and correct.
- Terminal screws must be tight, especially on the power input and output of the inverter.
- Do not perform any insulation test on the control circuit.

Chapter 6 Peripherals Components

6.1 Reactor Specifications

Model: L510-□□□-SHXX-X	Specification	
	Current (A)	Inductance (mH)(Note1)
2P2	4.9	4.48
2P5	7.2	3.05
201	11.0	2.00
202	15.5	1.42
203	21.0	1.05
205	20.0	0.63
208	33.0	0.38
210	42.0	0.30
401	4.2	5.25
402	5.6	3.94
403	7.3	3.02
405	12.0	1.84
408	17.0	1.30
410	23.0	0.96
415	31.0	0.71

Note1 : Calculated inductance based on 3% reactance

6.2 Electromagnetic Contactor and No fuse circuit breaker

Model: L510-□□□-SHXX-X	Molded-case circuit breaker made by TECO	Magnetic contactor (MC) made by TECO
1P2/1P5/2P2/2P5	TO-50E 15A	CN-11
101/201/202	TO-50E 20A	
203/205	TO-50E 30A	
401/402/403/405	TO-50EC 15A	
208	TO-50E 50A	
210	TO-100S 60A	
408	TO-50E 20A	
410	TO-50E 30A	
415	TO-50E 50A	

6.2.1 EMC External Filter (C2 Level)

Frame	Inverter Model	Input Voltage	Model of External Filter
1	L510-2P2/2P5/201-SH1-X	Single Phase 200~240V	E2F-2102
1	L510-2P2/2P5/201-SH3-X	Single Phase 200~240V	FN3258-16-45
2	L510-1P5/101-SH1-X	Single Phase 100~120V	FS6146-27-07
2	L510-202/203-SH1-X	Single Phase 200~240V	FVSB-055B
2	L510-202/203-SH3-X	Three Phase 200~240V	FN3258-16-45
2	L510-401/402/403-SH3-X	Three Phase 380~480V	FN3258-16-45
3	L510-205-SH3	Three Phase 200~240V	FS32124-23-99
3	L510-405/408-SH3	Three Phase 380~480V	FN3258-16-45
4	L510-208/210-SH3	Three Phase 200~240V	FS29020-42-99
4	L510-410/415-SH3	Three Phase 380~480V	FN3258-42-47

6.3 Fuse Specification

Model: L510-□□□-SHX(F)-X L510-□□□-SHX	HP	KW	Rating
1P2/1P5	0.25/0.5	0.2/0.4	15A, 300VAC
101	1	0.75	20A, 300VAC
2P2	0.25	0.2	10A, 300VAC
2P5/201	0.5/1	0.4/0.75	15A, 300VAC
202/203	2/3	1.5/2.2	30A, 300VAC
205	5	3.7	30A, 300VAC
208/210	7.5/10	5.5/7.5	60A, 300VAC
401	1	0.75	5A, 600VAC
402	2	1.5	15A, 600VAC
403/405	3/5	2.2/3.7	20A, 600VAC
408/410	7.5/10	5.5/7.5	40A, 600VAC
415	15	11	70A, 600VAC

6.4 Fuse Specification(UL Model Recommended)

Model	Manufacture	Type	Rating
L510-1P2-SH1-X	Bussmann	16CT	690V 16A
L510-1P5-SH1-X	Bussmann	20CT	690V 20A
L510-101-SH1-X	Bussmann	25ET	690V 25A
L510-2P2-SH1(F)-X	Bussmann	10CT KLM-10	690V 10A 600V 10A
L510-2P5-SH1(F)-X	Bussmann	10CT/16CT KLM-10/KLM-15	690V 10A/690V 16A 600V 10A/600V 15A
L510-201-SH1(F)-X	Bussmann	16CT/20CT KLM-20	690V 16A/690V 20A 600V 20A
L510-202-SH1(F)-X	Bussmann	30FE	690V 30A
L510-203-SH1(F)-X	Bussmann	50FE	690V 50A
L510-2P2-SH3-X	Bussmann	10CT	690V 10A
L510-2P5-SH3-X	Bussmann	10CT	690V 10A
L510-201-SH3-X	Bussmann	10CT	690V 10A
L510-202-SH3-X	Bussmann	16CT	690V 16A
L510-203-SH3-X	Bussmann	20CT	690V 20A
L510-205-SH3	Bussmann	50FE	690V 50V
L510-208-SH3	Bussmann	63/100 FE	690V 63A
L510-210-SH3	Bussmann	80/100 FE	690V 80/690V100A
L510-401-SH3-X	Bussmann	10CT	690V 10A
L510-402-SH3-X	Bussmann	16CT	690V 16A
L510-403-SH3-X	Bussmann	20CT	690V 20A
L510-405-SH3(F)	Bussmann	25ET	690V 25A
L510-408-SH3(F)	Bussmann	40FE	690V 40A
L510-410-SH3(F)	Bussmann	50ET	690V 50A
L510-415-SH3(F)	Bussmann	63ET	690V 63A

6.5 Braking Resistor

Inverter			Catalog Number of Braking Resistor		Specification		Specification of Braking Resistor		Braking Torque	Minimum value of Resistor	
V	HP	KW	Number of Braking Resistor	Qty	(W)	(Ω)	(LxWxH)mm	Qty	10% ED	(Ω)	(W)
220V 3Ph	5	4	JNBR-390W40	1	390	40	390W/40Ω(395x40x78)	1	119	17	1000
	7.5	5.5	JNBR-520W30	1	520	30	520W/30Ω(400x50x100)	1	108	17	1000
	10	7.5	JNBR-780W20	1	780	20	780W/20Ω(400x50x100)	1	119	11	1500
400V 3Ph	1	0.75	JNBR-150W750	1	150	750	150W/750Ω(251x28x60)	1	126	120	600
	2	1.5	JNBR-150W400	1	150	400	150W/400Ω(251x28x60)	1	119	120	600
	3	2.2	JNBR-260W250	1	260	250	260W/250Ω(274x40x78)	1	126	100	680
	5	4	JNBR-400W150	1	400	150	400W/150Ω(395x40x78)	1	126	60	1200
	7.5	5.5	JNBR-600W130	1	600	120	600W/130Ω(395x40x78)	1	102	43	1600
	10	7.5	JNBR-800W100	1	800	100	800W/100Ω(535x60x110)	1	99	69	1100
	15	11	JNBR-1R6KW50	1	1600	50	1600W/50Ω(615x60x110)	1	126	43	1600

※**Note:** Braking resistor : $W = (V_{pnb} * V_{pnb}) * ED\% / R_{min}$

1. W: The power consumption of braking action
2. V_{pnb}: The voltage of braking action (220V=380VDC, 440V=780VDC)
3. ED%: The effective period of braking action
4. R_{min}: braking resistor minimum value (ohms)

6.6 Copy Unit(JN5-CU)

The copy unit is used to copy an inverter parameter setup to another inverter. The copy unit saves time in applications with multiple inverters requiring the same parameter setup

Copy Unit (JN5-CU) dimensions

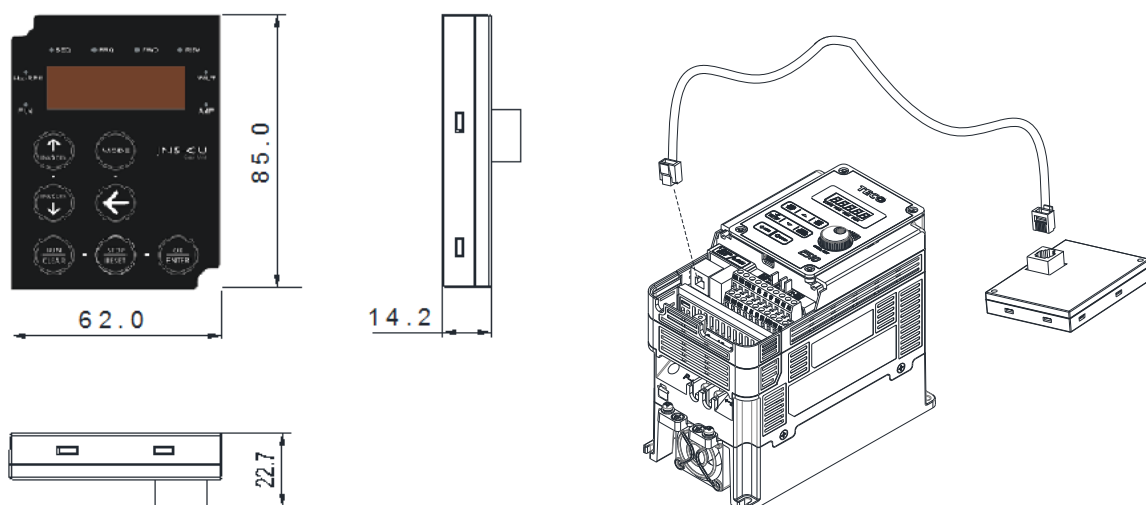

Note: Firmware version 1.4 starts to support constant pressure PUMP function.

➤ **Applicable Conditions of JN5-CU**

Inverter	Parameter Setting of Keypad Display	Parameters of Motor	Notes
Same series Same horsepower	Can be copied	Can be copied	Parameters can be copied from old version to new version.
Same series Different horsepower	Can be copied	Can't be copied	Parameters can be copied from old version to new version.
Different series	Can't be copied	Can't be copied	-

6.7 Communication options

(a) PROFIBUS communication interface module (JN5-CM-PDP)

For wiring example and communication setup refer to JN5-CM-PDP communication option manual.

(b) DEVICENET communication interface module (JN5-CM-DNET)

For wiring example and communication setup refer to JN5-CM-DNET communication option manual.

(c) CANopen communication interface module (JN5-CM-CAN)

For wiring example and communication setup refer to JN5-CM-VAN communication option manual.

(d) TCP-IP communication interface module (JN5-CM-TCPIP)

For wiring example and communication setup refer to JN5-CM-TCPIP communication option manual.

(e) EtherNet/IP communication interface module (JN5-CM-EIP)

For wiring example and communication setup refer to JN5-CM-EIP communication option manual.

6.8 RJ45 to USB connecting Cable (1.8m)

JN5-CM-USB has the function of converting USB communication format to RS485 to achieve the inverter communication control being similar with PC or other control equipment with USB port.

Exterior:

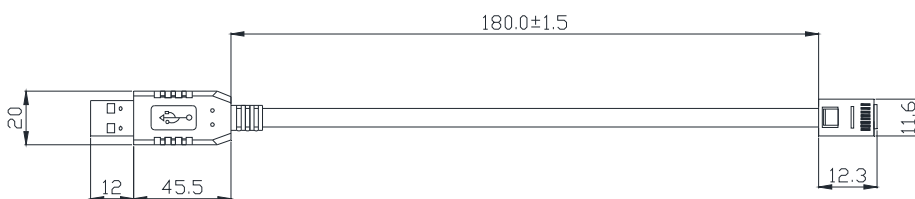

Connecting:

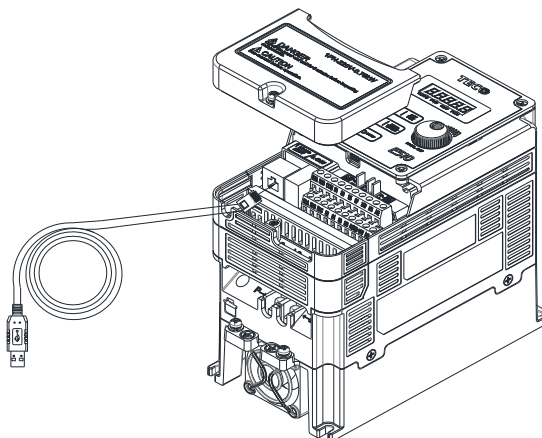

6.9 Remote Keypad (JN5-OP-L01)

- Please connect L510s inverter and JN5-OP-L01 (Fig.1)
- After setting parameter 09-02=4, please disconnect the input power and restart again, run command and frequency command will transfer to external remote keypad.
(Inverter just keep "STOP" key function)
- If set 09-02=4 without remote keypad connected, inverter will show "OPErr" error message (Fig.2), please remove "OPErr" error message by the following steps:
 - (a) Please remove the "OPErr" message by "RESET" key of inverter keypad.
 - (b) Set 09-02=0~3
 Error code "OPErr" message will be removed.
- If CF00 or CF01 occurred, please check parameter 09-02 setting or connection cable.



(Fig.1)



(Fig.2)

➤ Dimensions:

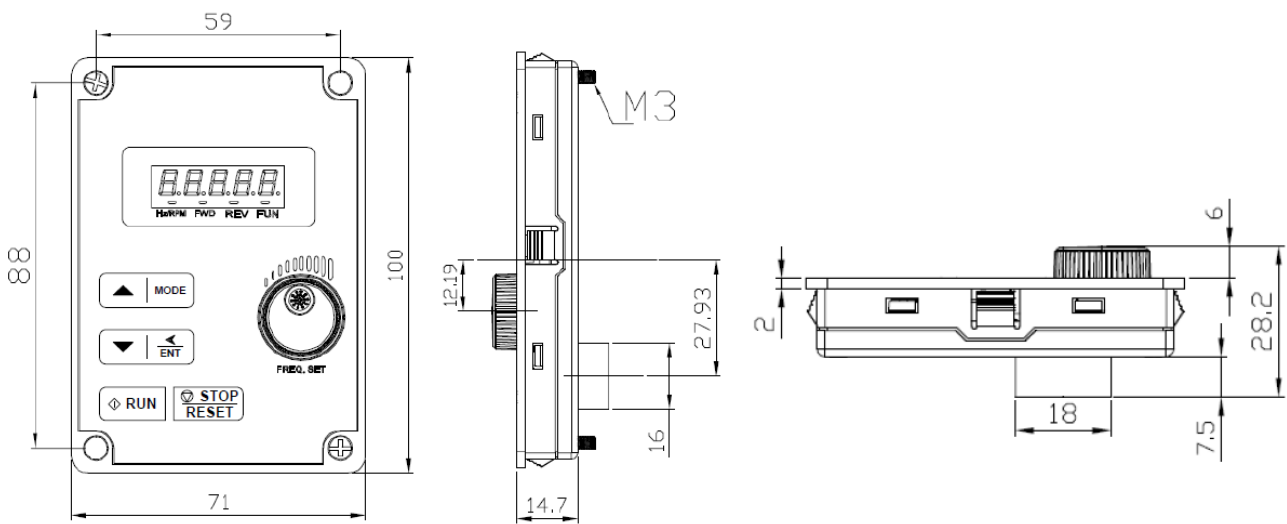

(Fig.3)

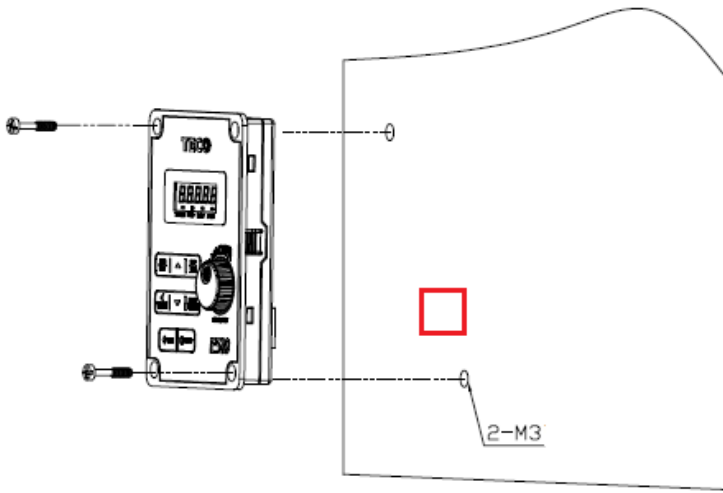

(Fig.4)

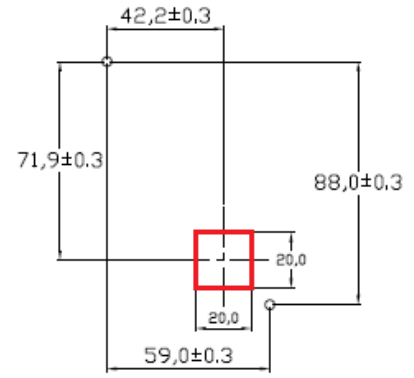

6.10 JN5-CM-EIP Manual

6.10.1 Preparations before using the instrument

- 510 series inverter *1
- IBM PC or compatible computer (with the following related software installed) *1
 - BOOTP-DHCP Tool (Rockwell IP setting software)
 - RSlinx Classic (Rockwell communication software)
 - Connected Components Workbench (Rockwell PLC software)
 - Molex Ethernet/IP Tool (Ethernet IP setting software)
- Ethernet/IP Programmable Logic Controller (EX: Micro820) *1
- CAT5e Ethernet cable *3
- DC Power supply *1

6.10.2 Installation of a semi-finished product

- Connected the power terminal of the module to the DC power supply.
- Open the top cover of the inverter, and connect the CN1 of the communication module to the RJ45 communication port of the inverter by CAT5e cable.
- 510 inverter parameter settings

Run command	Communication method	00-02=2
Frequency command	Communication method	00-05=5
Acceleration time	10.0s	00-14=100
Deceleration time	10.0s	00-15=100

Note: CN1 position



6.10.3 Connection steps

- Connect with the PC network and set the IP (as shown in the figure below, set the PC network card IP).

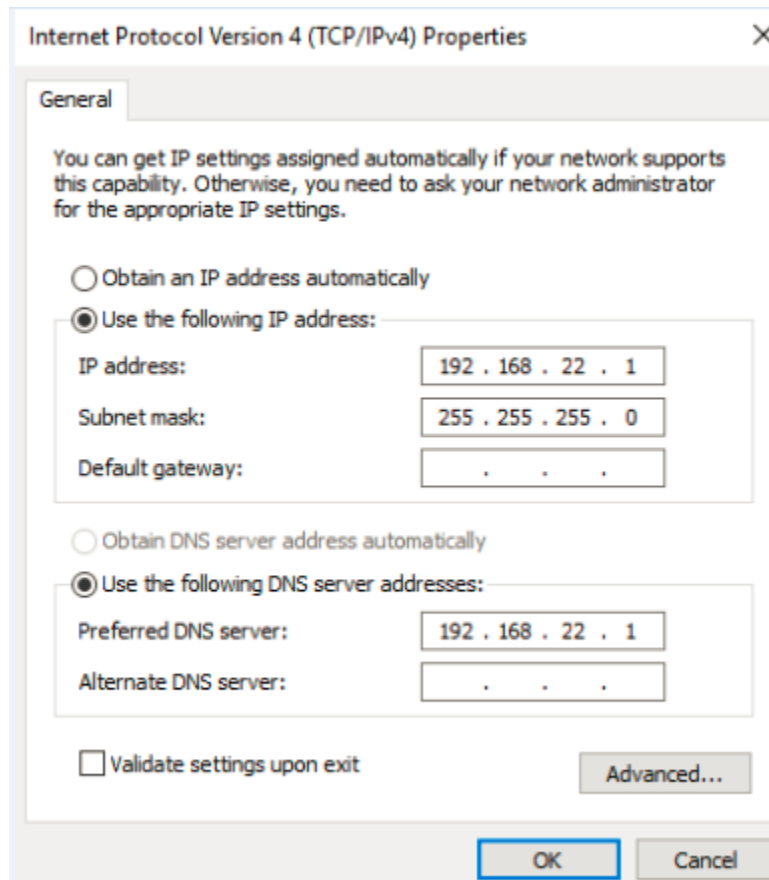

- Execute the Rockwell BOOTP-DHCP Tool and select the PC network card

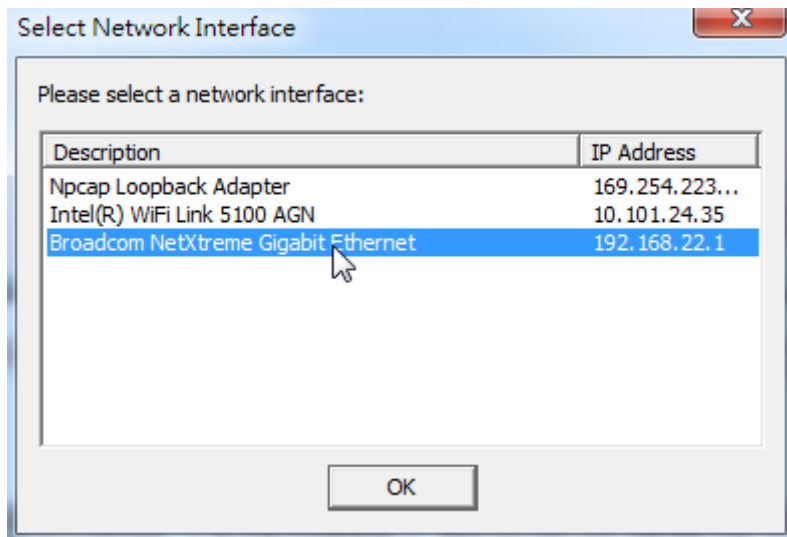

- The Rockwell BOOTP-DHCP Tool scans the MAC Address of the communication module, then select ADD RELATION and set the CLIENT IP ADDRESS to 192.168.22.2

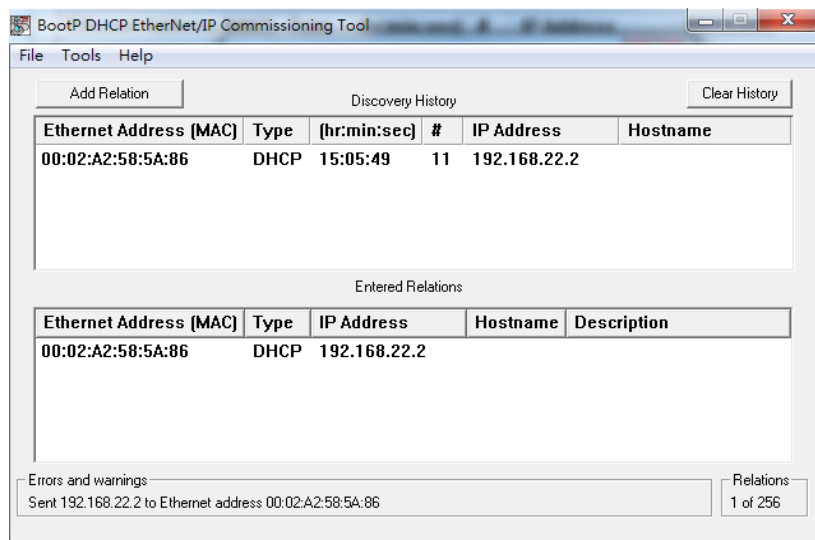
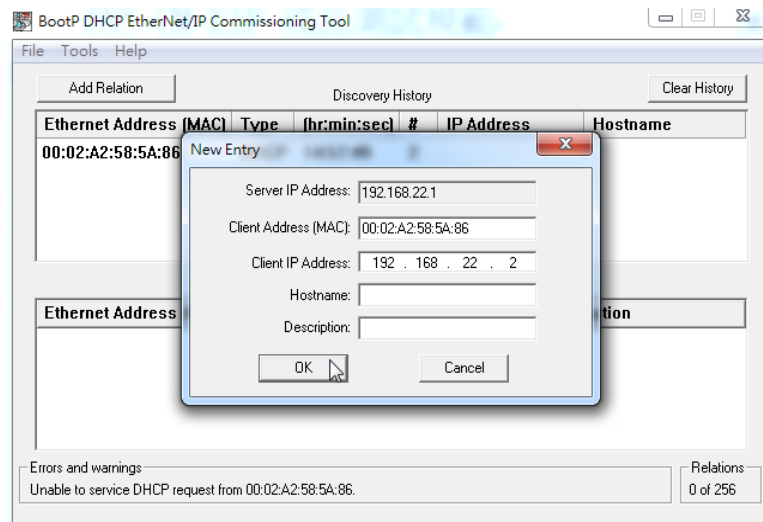
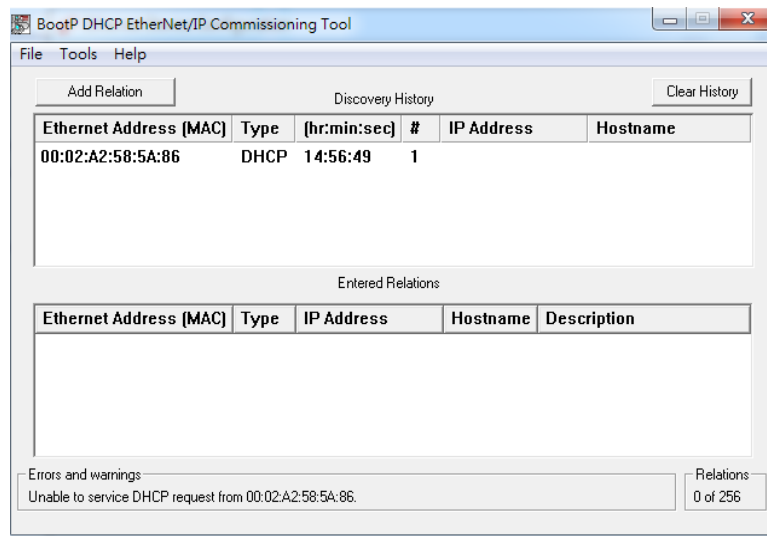

- Set and confirm the IP status (using Micro820 as the example) of the 510 communication module (Ethernet/IP).

Execute Connected Components Workbench, open a Project file and set the Micro800 PLC address (192.168.22.4) and subnet mask (255.255.255.0); they do not need to be changed again after the setting is completed

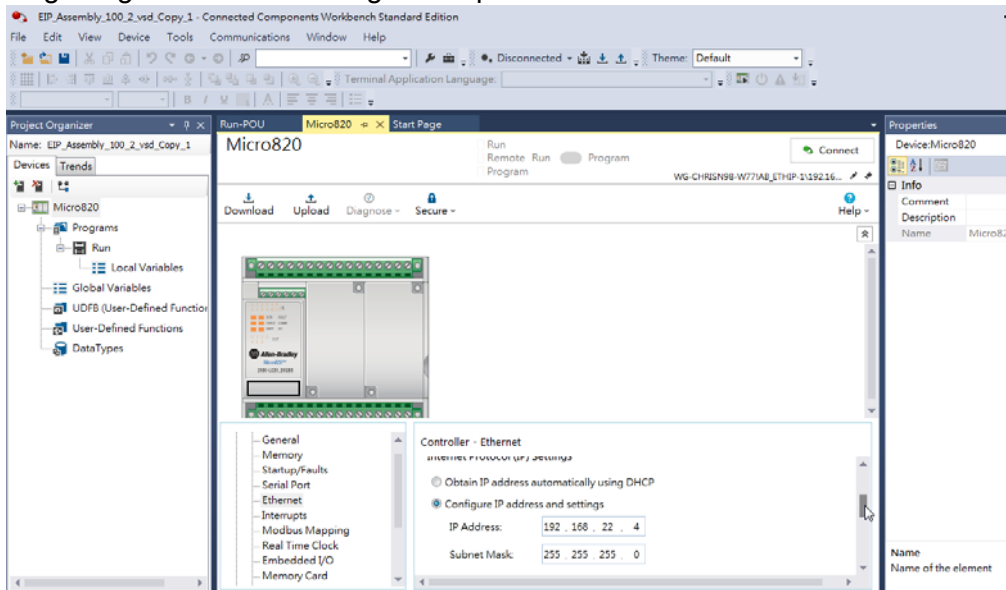

Check whether the network connection is successful, as shown in the figure below. Execute RSlinx Classic Lite and execute Configure Drivers.

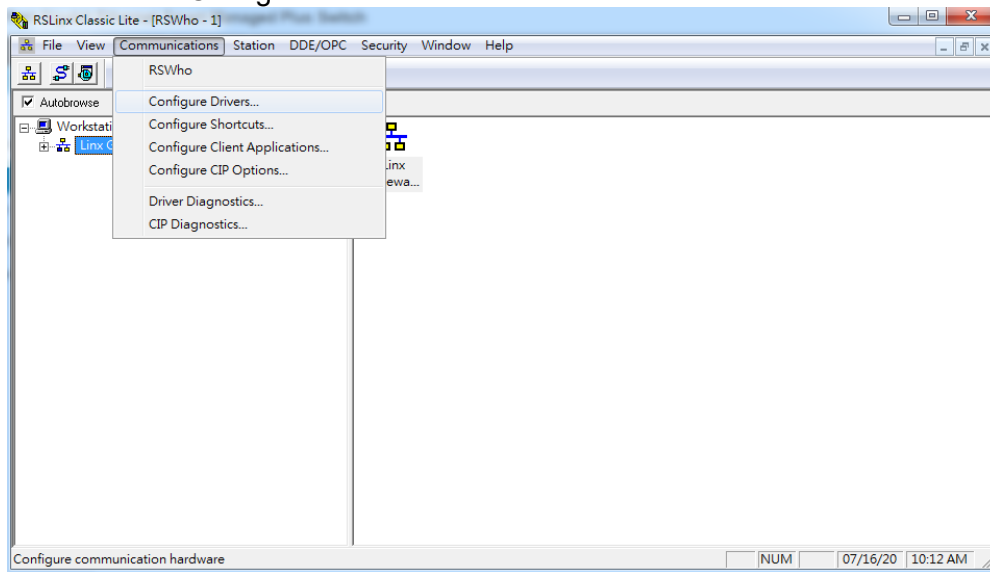

Select Ethernet/IP Driver, Add new, and select the IP of the PC network card

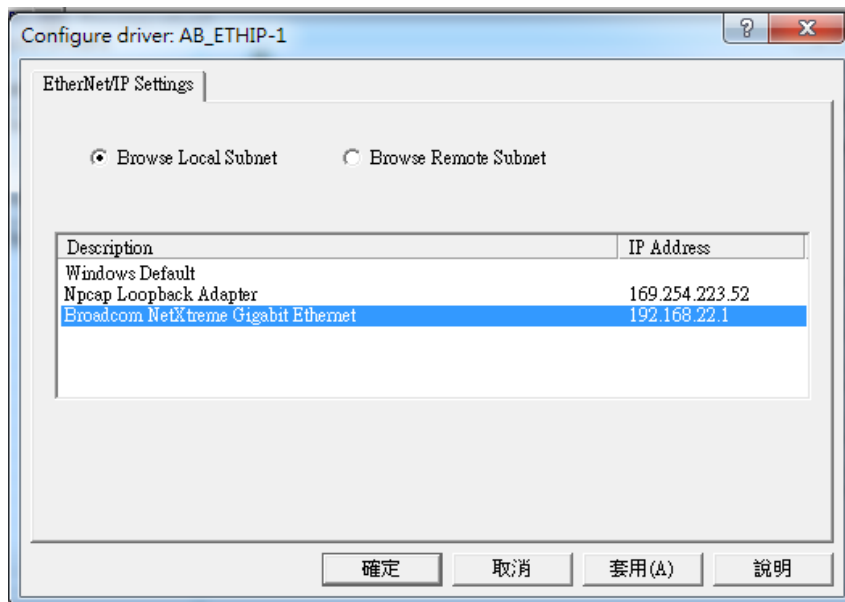
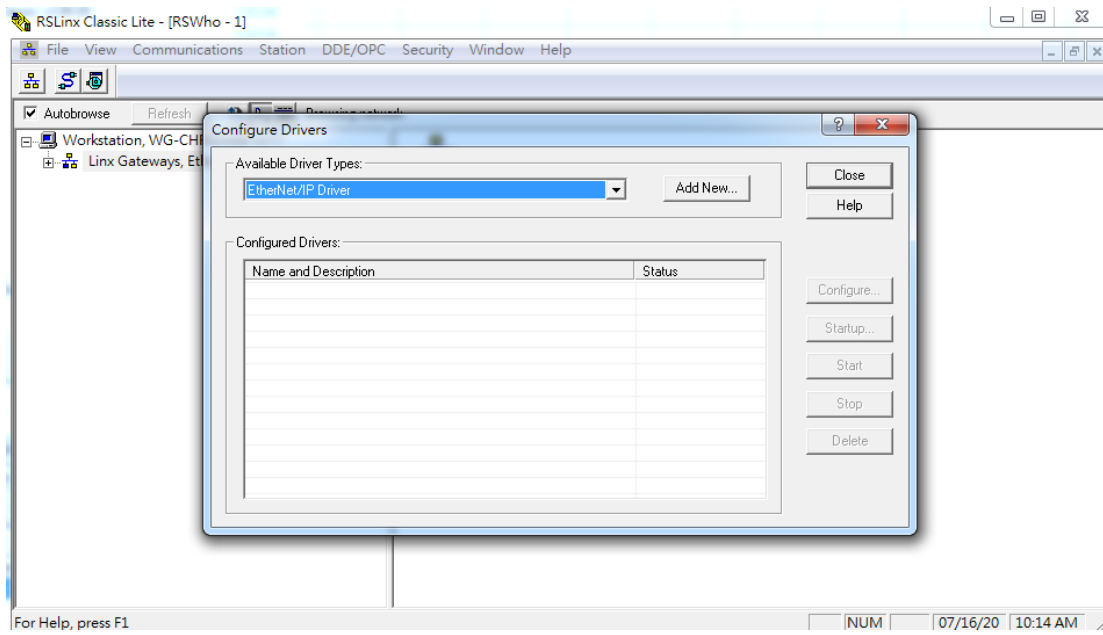

Expand AB_ETHIP-1, the PLC (192.168.22.4) and the communication module (192.168.22.2) can be seen.

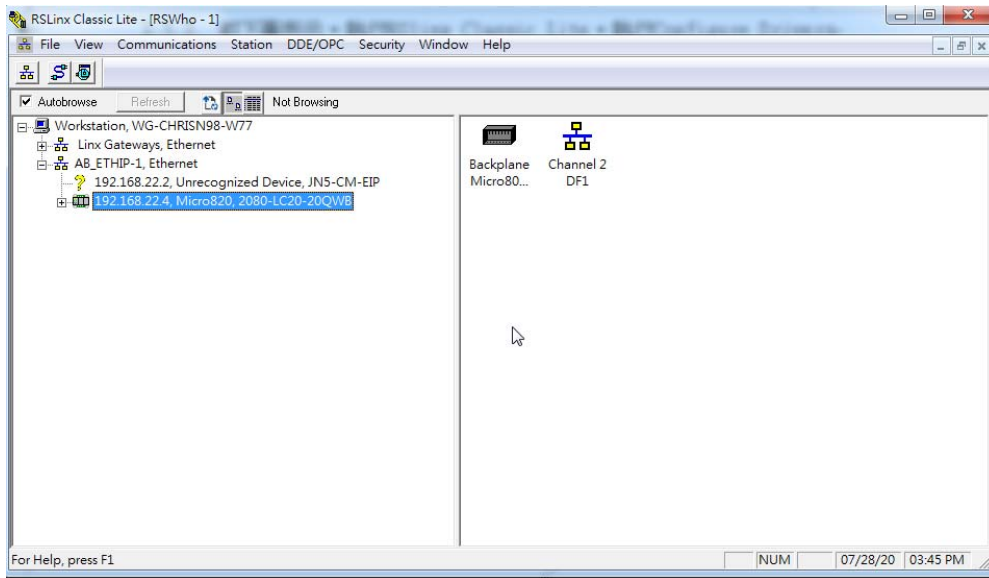

Open the CCW project file and confirm that the IP DHCP is assigned to the expansion card for Local Variables -> A_TarCfg.Path is 192.168.22.2.

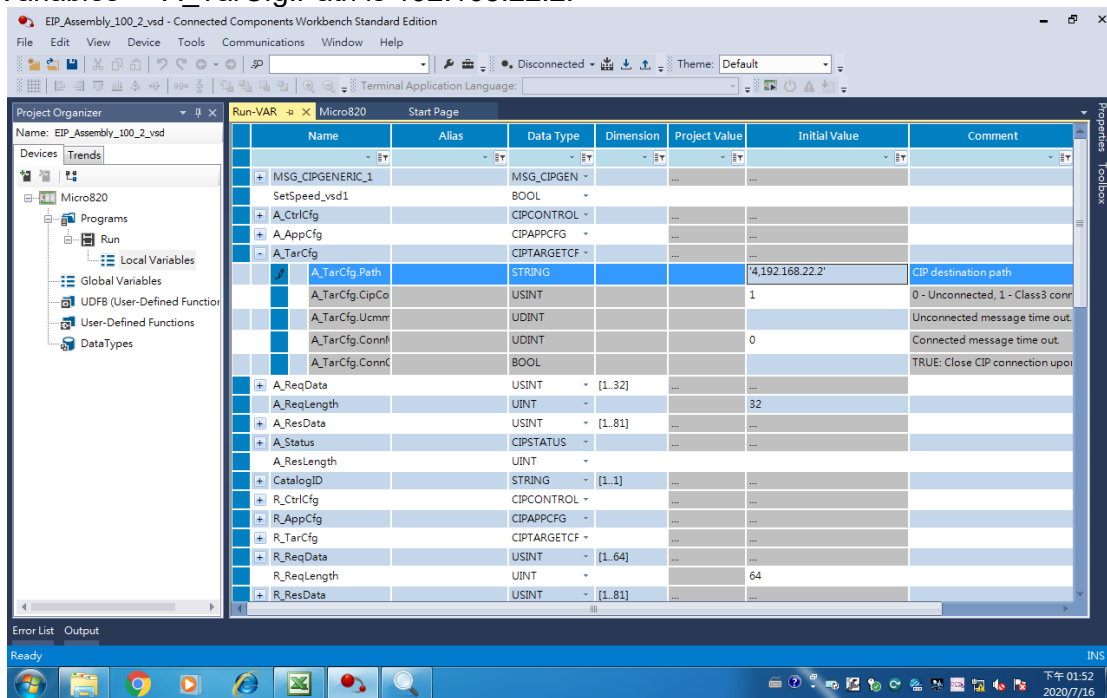

- Set the “Connected Components Workbench” communication software.

Open the “Connected Components Workbench” communication software as shown in the figure below, select the connected device and select “Local Variables.” Confirm that the IP DHCP assigned to the expansion card is 192.168.22.2 for A_TarCfg.Path.

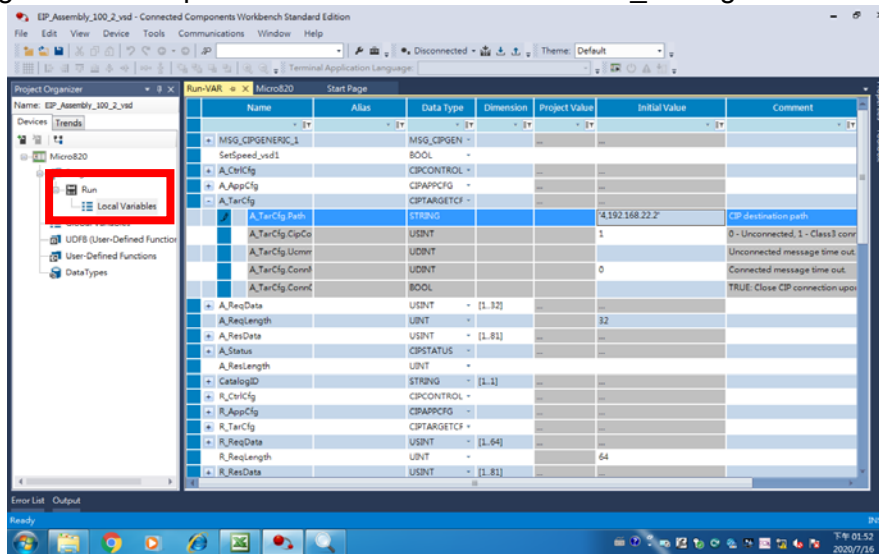

Select “Build Project”

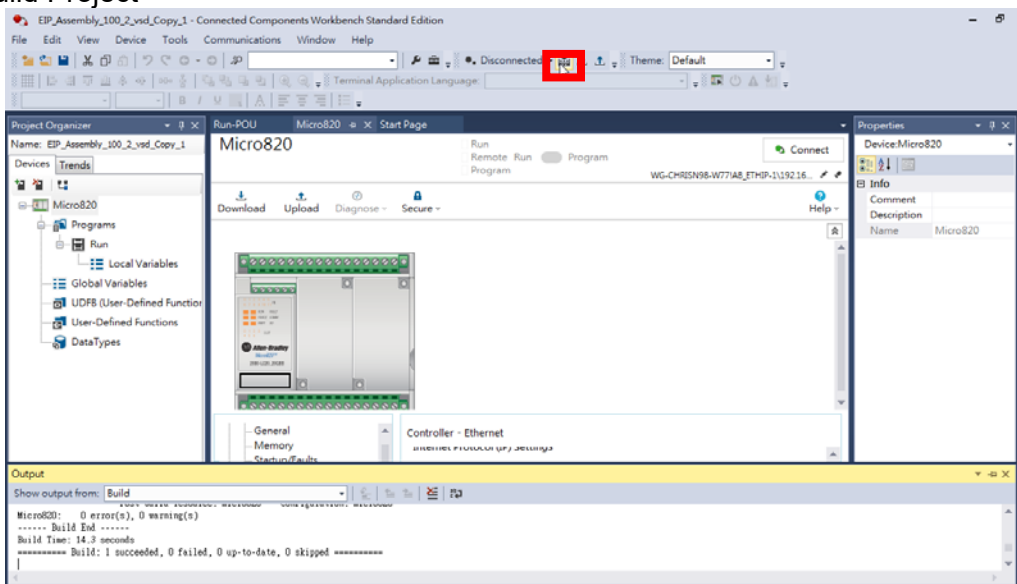

Press the “Download” button to complete the PC to PLC setting.

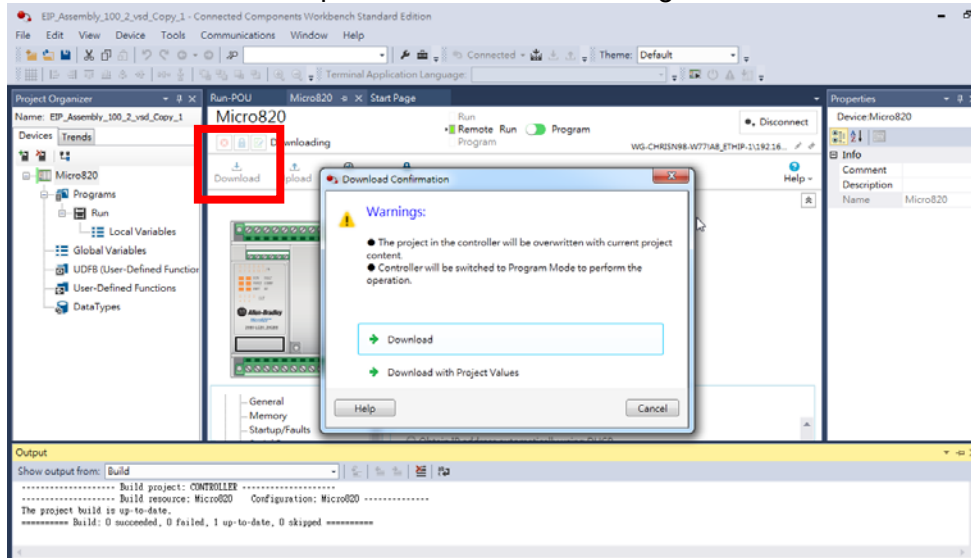

After download, it will execute the connection between the communication module and PLC automatically, as shown in the figure below.

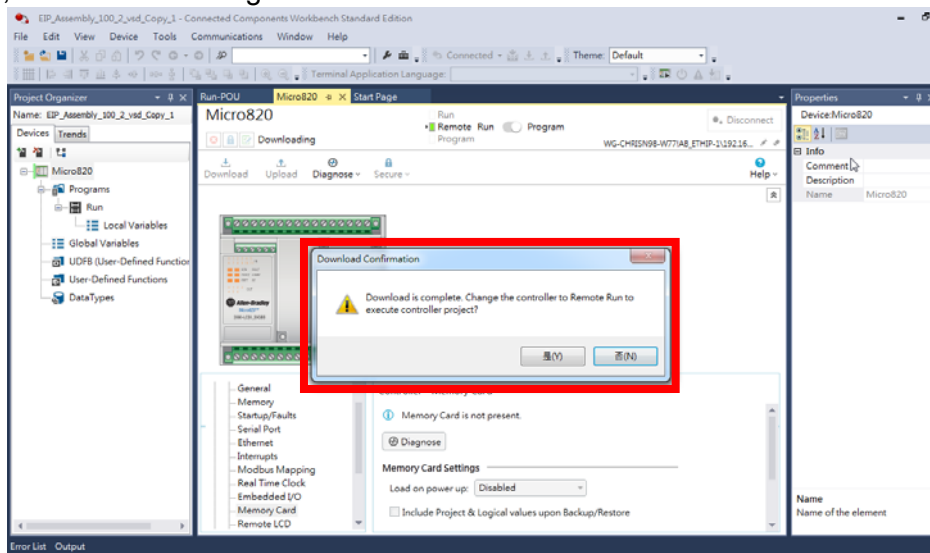

6.10.4 Running

- The connected 510 communication module (Ethernet/IP), as shown in the figure below.

Confirm that Remote Run is enabled.

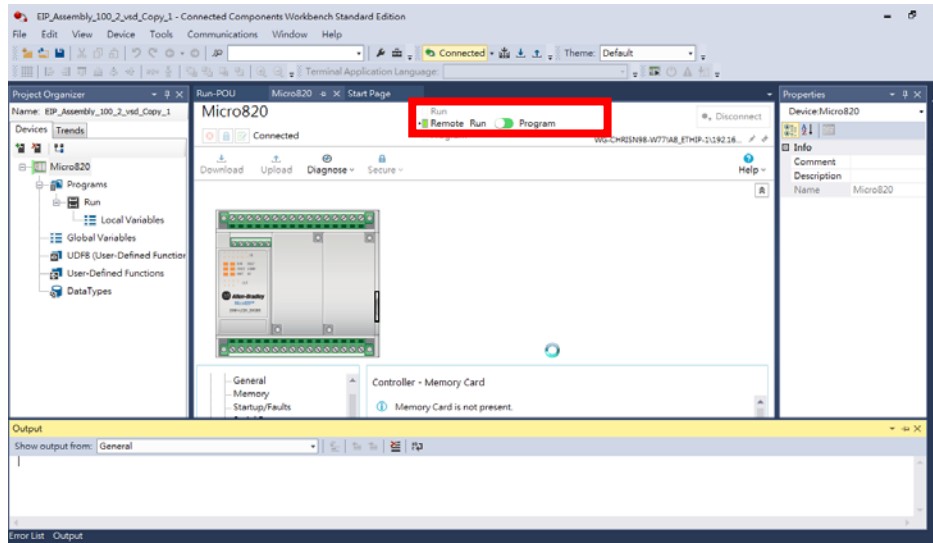

As shown in the figure below, select and open “RUN_POU.”

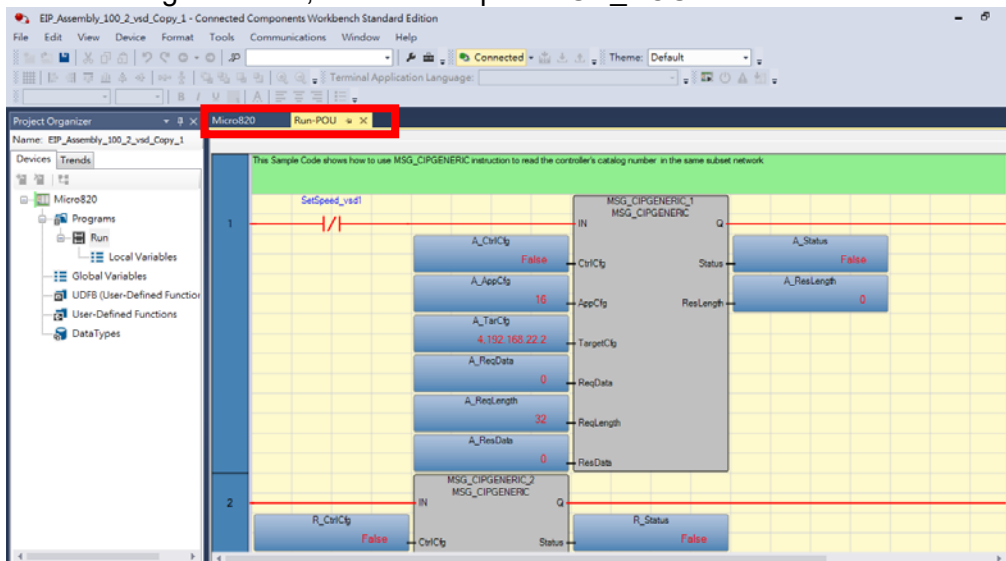

Load A_ReqData and check whether the Input Assembly content was written.

PLC command address	MODBUS register address	Description
A_ReqData[1]	2501 Low Byte	RUN/STOP FWD/REV
A_ReqData[2]	2501 High Byte	
A_ReqData[3]	2502 Low Byte	Frequency command
A_ReqData[4]	2502 High Byte	

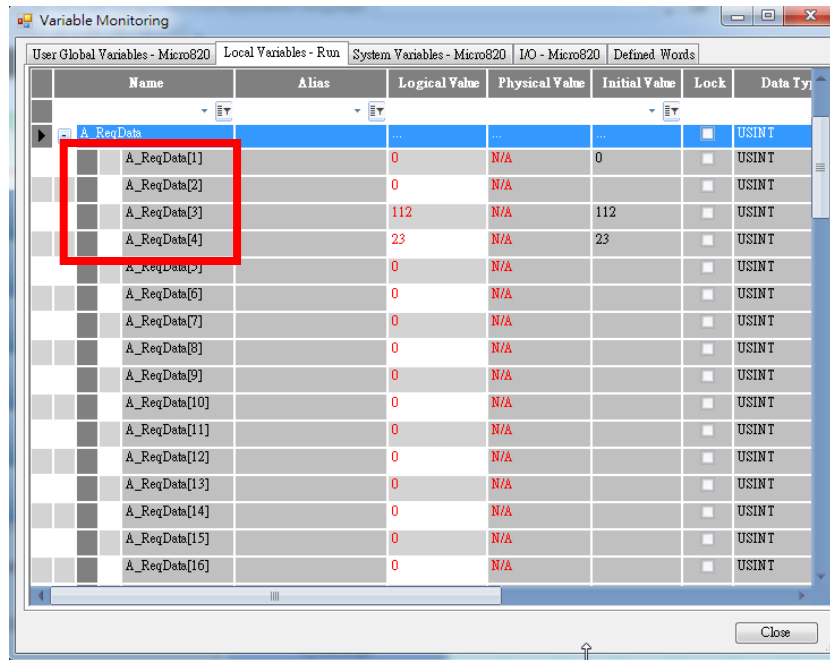

Load R_ResData and check whether the Output Assembly content was read.

PLC command address	MODBUS register address	Description
R_ResData[1]	2520 Low Byte	Inverter status
R_ResData[2]	2520 High Byte	
R_ResData[3]	2521 Low Byte	Error description
R_ResData[4]	2521 High Byte	
R_ResData[5]	2522 Low Byte	DI status
R_ResData[6]	2522 High Byte	
R_ResData[7]	2523 Low Byte	Frequency command
R_ResData[8]	2523 High Byte	
R_ResData[9]	2524 Low Byte	Output frequency
R_ResData[10]	2524 High Byte	

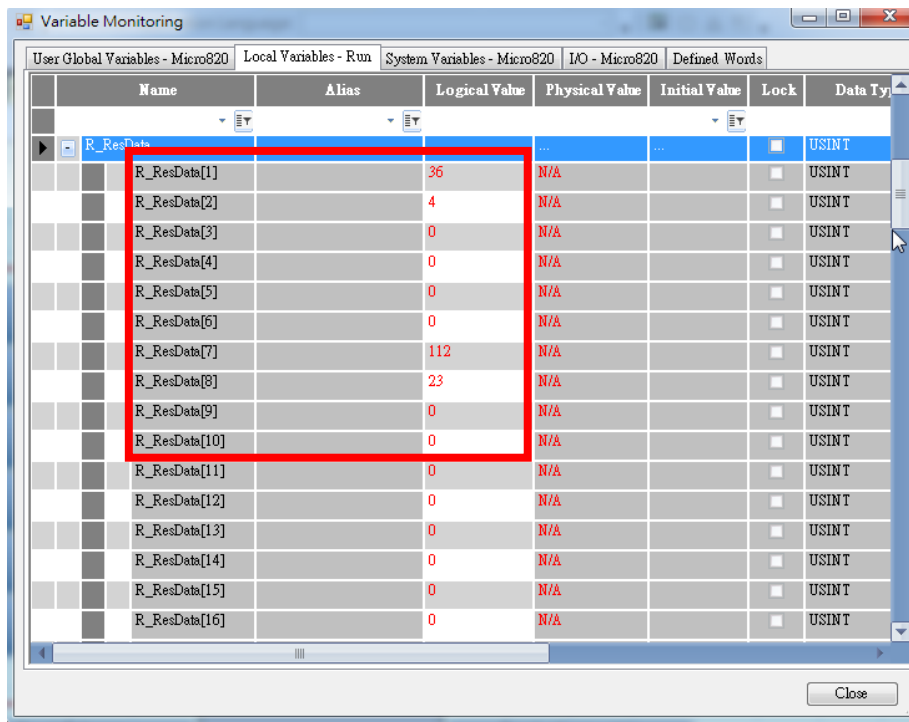

Execute Molex Ethernet/IP Tool and send the UCMM read command (Get Attribute) to the 510 communication module (Ethernet/IP); the response that can be received from the communication module is as shown in the figure below.

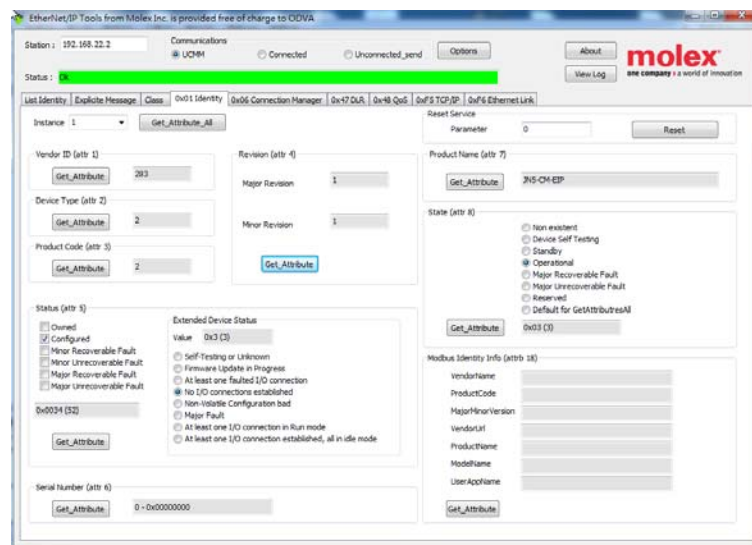

Class	Instance	Attribute	Name	Default	R/W	Size
0x01	1	1	Vendor ID	283	R	U32
0x01	1	2	Device Type	2	R	U32
0x01	1	3	Product code	2	R	U32
0x01	1	4	Major Revision	1	R	U32
0x01	1	5	Minor Revision	1	R	U32

The run command sent to the inverter written with the PLC command is as follows

Commands can be sent to the inverter through PLC from the following switch A_ReqData[1] inverter operation signal (2501H)

PLC command address	Function	Description
A_ReqData[1].0	Operation status	1 : RUN 0 : STOP
A_ReqData[1].1	Direction status	1 : REV 0 : FWD
A_ReqData[1].2	External error	1:EF0
A_ReqData[1].3	Error reset	1 : RESET

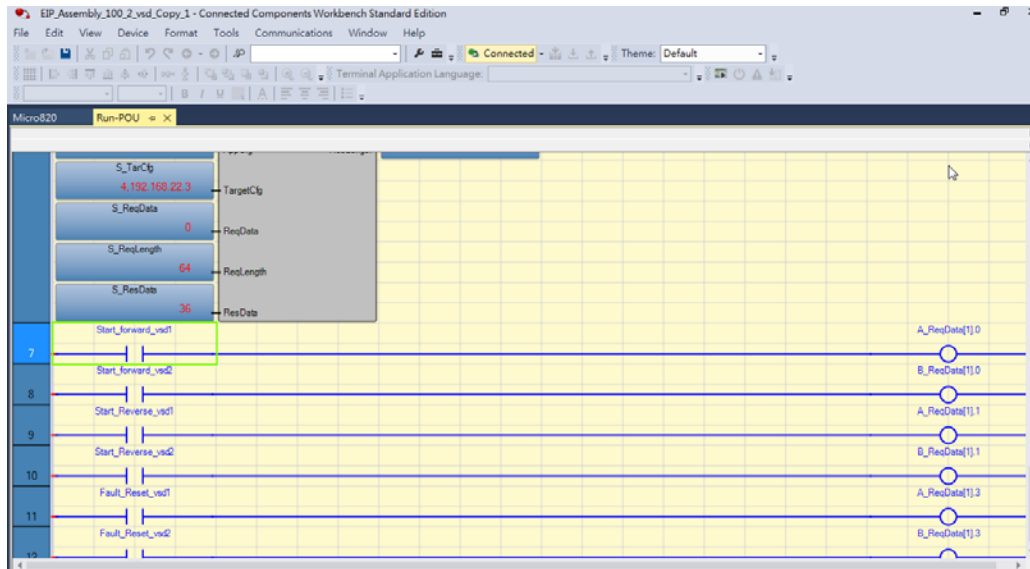

The run command sent to the inverter written with the Moxel Ethernet/IP Tool is as follows

Service Code No.	Service Name
0E(HEX)	Get Attribute Single
10(HEX)	Set Attribute Single

Class(HEX)	2A	29	29
Instance(HEX)	1	1	1
Attribute(HEX)	8	3	4
Write data(HEX)	0~70 17	0~1	0~1
Corresponding command	SPEED REFERENCE	1:RUN FORWARD 0: STOP	1:REVERSE RUN 0: STOP
Inverter action	Panel frequency 60Hz	Forward rotation	Reversed rotation

Appendix 1 L510s parameters setting list

Customer				Inverter Model			
Using Site				Contact Phone			
Address							
Parameter Code	Setting Content	Parameter Code	Setting Content	Parameter Code	Setting Content	Parameter Code	Setting Content
00-00		02-00		03-00		04-00	
00-01		02-01		03-01		04-01	
00-02		02-02		03-02		04-02	
00-03		02-03		03-03		04-03	
00-04		02-04		03-04		04-04	
00-05		02-05		03-05		04-05	
00-06		02-06		03-06		04-06	
00-07		02-07		03-07		04-07	
00-08		02-08		03-08		04-08	
00-09		02-09		03-09		04-09	
00-10		02-10		03-10		04-10	
00-11		02-11		03-11		04-11	
00-12		02-12		03-12		04-12	
00-13		02-13		03-13		04-13	
00-14		02-14		03-14		04-14	
00-15		02-15		03-15		04-15	
00-16		02-16		03-16			
00-17		02-17		03-17			
00-18		02-18		03-18			
00-19		02-19		03-19			
00-20				03-20			
01-00				03-21			
01-01							
01-02							
01-03							
01-04							
01-05							
01-06							
01-07							
01-08							
01-09							
01-10							
01-11							
01-12							
01-13							
01-14							
01-15							
01-16							
01-17							
01-18							

Parameter Code	Setting Content	Parameter Code	Setting Content	Parameter Code	Setting Content	Parameter Code	Setting Content
05-00		06-00		07-00		08-00	
05-01		06-01		07-01		08-01	
05-02		06-02		07-02		08-02	
05-03		06-03		07-03		08-03	
05-04		06-04		07-04		08-04	
05-05		06-05		07-05		08-05	
05-06		06-06		07-06		08-06	
05-07		06-07		07-07		08-07	
05-08		06-16		07-08		08-08	
05-17		06-17		07-09		08-09	
05-18		06-18				08-10	
05-19		06-19				08-11	
05-20		06-20				08-12	
05-21		06-21				08-13	
05-22		06-22				08-14	
05-23		06-23				08-15	
05-24		06-32				08-16	
05-25		06-33				08-17	
05-26		06-34				08-18	
05-27		06-35					
05-28		06-36					
05-29		06-37					
05-30		06-38					
05-31		06-39					
05-32							

Parameter Code	Setting Content	Parameter Code	Setting Content	Parameter Code	Setting Content	Parameter Code	Setting Content
09-00		10-00		11-00		12-00	
09-01		10-01		11-01		12-01	
09-02		10-02		11-02		12-02	
09-03		10-03		11-03		12-03	
09-04		10-04		11-04		12-04	
09-05		10-05		11-05		12-05	
09-06		10-06		11-06			
09-07		10-07		11-07			
09-08		10-08		11-08			
09-09		10-09		11-09			
09-10		10-10		11-10			
		10-11		11-11			
		10-12		11-13			
		10-13		11-14			
		10-14		11-15			
		10-15		11-16			
		10-16		11-17			
		10-17		11-18			
		10-18		11-19			
		10-19		11-20			
		10-20					
		10-21					
		10-22					

Parameter Code	Setting Content	Parameter Code	Setting Content	Parameter Code	Setting Content	Parameter Code	Setting Content
13-00		14-00		14-78			
13-01		14-01		14-79			
13-02		14-02		14-80			
13-03		14-03					
13-04		14-04					
13-05		14-05					
13-06		14-06					
13-07		14-07					
13-08		14-08					
		14-09					
		14-10					
		14-11					
		14-12					
		14-13					
		14-14					
		14-15					
		14-16					
		14-17					
		14-18					
		14-19					
		14-20					
		14-22					
		14-23					
		14-24					
		14-25					
		14-26					
		14-27					
		14-28					
		14-29					
		14-30					
		14-31					
		14-34					
		14-35					
		14-37					
		14-38					
		14-39					
		14-71					
		14-72					
		14-73					
		14-74					
		14-75					
		14-76					
		14-77					

Appendix-2 Instructions for UL

◆ Safety Precautions

DANGER

Electrical Shock Hazard

Do not connect or disconnect wiring while the power is on.

Failure to comply will result in death or serious injury.

WARNING

Electrical Shock Hazard

Do not operate equipment with covers removed.

Failure to comply could result in death or serious injury.

The diagrams in this section may show drives without covers or safety shields to show details. Be sure to reinstall covers or shields before operating the drives and run the drives according to the instructions described in this manual.

Always ground the motor-side grounding terminal.

Improper equipment grounding could result in death or serious injury by contacting the motor case.

Do not touch any terminals before the capacitors have fully discharged.

Failure to comply could result in death or serious injury.

Before wiring terminals, disconnect all power to the equipment. The internal capacitor remains charged even after the power supply is turned off. After shutting off the power, wait for at least the amount of time specified on the drive before touching any components.

Do not allow unqualified personnel to perform work on the drive.

Failure to comply could result in death or serious injury.

Installation, maintenance, inspection, and servicing must be performed only by authorized personnel familiar with installation, adjustment, and maintenance of AC drives.

Do not perform work on the drive while wearing loose clothing, jewelry, or lack of eye protection.

Failure to comply could result in death or serious injury.

Remove all metal objects such as watches and rings, secure loose clothing, and wear eye protection before beginning work on the drive.

Do not remove covers or touch circuit boards while the power is on.

Failure to comply could result in death or serious injury.

Fire Hazard

Tighten all terminal screws to the specified tightening torque.

Loose electrical connections could result in death or serious injury by fire due to overheating of electrical connections.

Do not use an improper voltage source.

Failure to comply could result in death or serious injury by fire.

Verify that the rated voltage of the drive matches the voltage of the incoming power supply before applying power.

Do not use improper combustible materials.

Failure to comply could result in death or serious injury by fire.

Attach the drive to metal or other noncombustible material.

NOTICE

Observe proper electrostatic discharge procedures (ESD) when handling the drive and circuit boards.

Failure to comply may result in ESD damage to the drive circuitry.

Never connect or disconnect the motor from the drive while the drive is outputting voltage.

Improper equipment sequencing could result in damage to the drive.

Do not use unshielded cable for control wiring.

Failure to comply may cause electrical interference resulting in poor system performance. Use shielded twisted-pair wires and ground the shield to the ground terminal of the drive.

NOTICE

Do not modify the drive circuitry.

Failure to comply could result in damage to the drive and will void warranty.

Teco is not responsible for any modification of the product made by the user. This product must not be modified.

Check all the wiring to ensure that all connections are correct after installing the drive and connecting any other devices.

Failure to comply could result in damage to the drive.

◆ UL Standards

The UL/cUL mark applies to products in the United States and Canada and it means that UL has performed product testing and evaluation and determined that their stringent standards for product safety have been met. For a product to receive UL certification, all components inside that product must also receive UL certification.



◆ UL Standards Compliance

This drive is tested in accordance with UL standard UL508C and complies with UL requirements. To ensure continued compliance when using this drive in combination with other equipment, meet the following conditions:

■ **Installation Area**

Do not install the drive to an area greater than pollution severity 2 (UL standard).

■ **Main Circuit Terminal Wiring**

UL approval requires crimp terminals when wiring the drive's main circuit terminals. Use crimping tools as specified by the crimp terminal manufacturer. Teco recommends crimp terminals made by NICHIFU for the insulation cap.

The table below matches drives models with crimp terminals and insulation caps. Orders can be placed with a Teco representative or directly with the Teco sales department.

Closed-Loop Crimp Terminal Size

Drive Model	Wire Gauge						Terminal	Crimp Terminal	Tool	Insulation Cap
	mm ² , (AWG)									
	R/L1	S/L2	T/L3	U/T1	V/T2	W/T3	Screws	Model No.	Machine No.	Model No.
L510s										
1P2			1.3(16)				M3.5	R2-3.5	Nichifu NH 1 / 9	TIC 2
1P5			2.1 (14)							TIC 2
101			3.3(12)				M4	R3.5-4	Nichifu NH 1 / 9	TIC 3.5
2P2			1.3(16)						Nichifu NH 1 / 9	TIC 2
2P5			1.3 (16)				M3.5	R2-3.5	Nichifu NH 1 / 9	TIC 2
201			2.1 (14)						Nichifu NH 1 / 9	TIC 2
202			3.3(12)				M4	R3.5-4	Nichifu NH 1 / 9	TIC 3.5
203			5.3(10)				M4	R5.5-4	Nichifu NH 1 / 9	TIC 3.5
205			5.3(10)				M4	R5.5-4	Nichifu NH 1 / 9	TIC 5.5
208/210			8.4 (14)				M5	R8-5	Nichifu NH 1 / 9	TIC 8
401			2.1 (14)						Nichifu NH 1 / 9	TIC 2
402			2.1 (14)				M4	R3.5-4	Nichifu NH 1 / 9	TIC 2
403			2.1 (14)						Nichifu NH 1 / 9	TIC 2
405			2.1(14)				M4	R2-3.5	Nichifu NH 1 / 9	TIC 2
408/410/415			8.4 (8)				M5	R8-5	Nichifu NH 1 / 9	TIC 8

◆ Type 1

During installation, all conduit hole plugs shall be removed, and all conduit holes shall be used.

Recommended Input Fuse Selection

Drive Model L510s	Fuse Type	
	Manufacturer: Bussmann	
	Model	Fuse Ampere Rating (A)
100 V Class Single-Phase Drives		
1P2	Bussmann 16CT	690V 16A
1P5	Bussmann 20CT	690V 20A
101	Bussmann 25ET	690V 25A

Drive Model L510s	Fuse Type	
	Manufacturer: Bussmann	
	Model	Fuse Ampere Rating (A)
200 V Class Single-Phase Drives		
2P2	Bussmann 10CT	690V 10A
2P5	Bussmann 10CT/16CT	690V 10A / 690V 16A
201	Bussmann 16CT/20CT	690V 16A / 690V 20A
202	Bussmann 30FE	690V 30A
203	Bussmann 50FE	690V 50A

Drive Model L510s	Fuse Type	
	Manufacturer: Bussmann	
	Model	Fuse Ampere Rating (A)
200 V Class Three-Phase Drives		
2P2	Bussmann 10CT	690V 10A
2P5	Bussmann 10CT	690V 10A
201	Bussmann 10CT	690V 10A
202	Bussmann 16CT	690V 16A
203	Bussmann 20CT	690V 20A
205	Bussmann 50FE	690V 50A
208	Bussmann 63CT/100FE	690V 63A
210	Bussmann 80CT/100FE	690V 80A/690V 100A

Drive Model L510s	Fuse Type	
	Manufacturer: Bussmann	
	Model	Fuse Ampere Rating (A)
400 V Class Three-Phase Drives		
401	Bussmann 10CT	690V10A
402	Bussmann 16CT	690V 16A
403	Bussmann 20CT	690V 20A
405	Bussmann 25ET	690V 25A
408	Bussmann 40FE	690V 40A
410	Bussmann 50ET	690V 50A
415	Bussmann 63ET	690V 63A

◆ **Motor Over temperature Protection**

Motor over temperature protection is not provided.
 Motor over temperature protection shall be provided in the end use application.

■ **Field Wiring Terminals**

All input and output field wiring terminals not located within the motor circuit shall be marked to indicate the proper connections that are to be made to each terminal and indicate that copper conductors, rated 80°C are to be used.

■ **Drive Short-Circuit Rating**

This drive has undergone the UL short-circuit test, which certifies that during a short circuit in the power supply the current flow will not rise above value. Please see electrical ratings for maximum voltage and table below for current.

- The MCCB and breaker protection and fuse ratings (refer to the preceding table) shall be equal to or greater than the short-circuit tolerance of the power supply being used.
- Suitable for use on a circuit capable of delivering not more than (A) RMS symmetrical amperes for (Hp) Hp in 240 / 480 V class drives motor ■ overload protection.

Horse Power (Hp)	Current (A)	Voltage (V)
0 - 50	5,000	240 / 480

◆ **Drive Motor Overload Protection**

Set parameter 02-01 (motor rated current) to the appropriate value to enable motor overload protection. The internal motor overload protection is UL listed and in accordance with the NEC and CEC.

■ **02-01 Motor Rated Current**

Setting Range: Model Dependent

Factory Default: Model Dependent

Set 02-01 to the full load amps (FLA) stamped on the nameplate of the motor.

■ **08-05 Motor Overload Protection Selection**

The drive has an electronic overload protection function (OL1) based on time, output current, and output frequency, which protects the motor from overheating. The electronic thermal overload function is UL-recognized, so it does not require an external thermal overload relay for single motor operation.

This parameter selects the motor overload curve used according to the type of motor applied.

Overload Protection Settings

Setting	Description
XXXX0	Disabled
XXXX1	Enabled

Sets the motor overload protection function in 08-05 according to the applicable motor.

Setting 08-05 = XXXX0. Disables the motor overload protection function when two or more motors are connected to a single inverter. Use an alternative method to provide separate overload protection for each motor such as connecting a thermal overload relay to the power line of each motor.

■

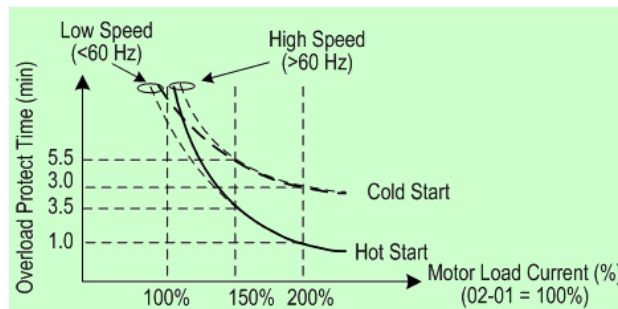

Motor Overload Protection Time

■ **08-06 Motor Overload Operation Selection**

Setting	Description
0	Free Run to Stop (default setting)
1	Alarm Only

Appendix 3 L510s Communication protocol

Modbus communication protocol

1. Communication Data Frame

L510s series inverter can be controlled by a PC or other controller with the Communication protocol, Modbus ASCII Mode & Mode RTU, RS485 or RS232. Frame length maximum 80 bytes.

1.1 Hardware installation

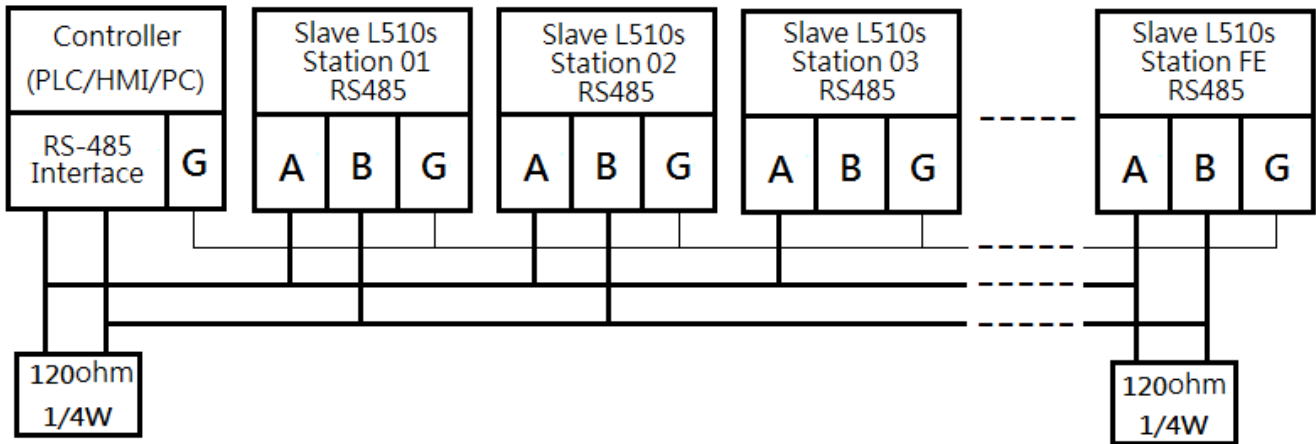

** The network is terminated at each end with an external terminating resistor (120Ω, 1/4w)**

1.2 Data format ASCII MODE

STX(3AH)	Start bit = 3AH
Address Hi	Communication Address(Station): 2-digit ASCII Code
Address Lo	
Function Hi	Function Code (command): 2-digit ASCII Code
Function Lo	
Command Start Address	Command Start byte: 4-digit ASCII Code
Command Start Address	
Command Start Address	
Command Start Address	
Data length	The length of the command: 4-digit ASCII Code
Data length	
Data length	
Data length	
LRC Check Hi	LRC Check Code: 2-digit ASCII Code
LRC Check Lo	
END Hi	End Byte : END Hi = CR(0DH) , END Lo= LF(0AH)
END L	

1.3 Data format (RTU Mode)

MASTER(PLC etc.) send request to SLAVE, whereas response to MASTER.

The signal receiving is illustrated here.

The data length is varied with the command (Function).

SLAVE Address
Function Code
DATA
CRC CHECK
Signal Interval

** The interval should be maintained at 10ms between command signal and request.

1.4 SLAVE(Address)

00H : Broadcast to all the drivers

01H : to the No.01 Drivers

0FH : to the No.15 Drivers

10H : to the No.16 Drivers

and so on....., Max to 32(20H)

1.5 Function Code

03H : Read the register contents

06H : write a WORD to register

08H : Loop test

10H : write several data to register(complex number register write)

2. CMS (Checksum and time-out definition)

2.1 LRC CHECK

Ex: ADDRESS 01H
 FUNCTION 03H
 COMMAND 01H
 00H
 DATA LENGTH 0AH

 0FH-----true complement
 Checksum = F1H
 CS(H) = 46H (ASCII)
 CS(L) = 31H (ASCII)

2.2 CRC CHECK

CRC Check Code is calculated from SLAVE Address to end of the data. The calculation method is illustrated as follow:

- (1). Load a 16-bit register with FFFF hex (all's1).Call this the CRC register.
- (2). Exclusive OR the first 8-bit byte of the message with the low-order byte of the 16-bit CRC register, putting the result in the CRC register.
- (3). Shift the CRC register one bit to the right (toward the LSB), Zero-filling the MSB, Extract and examines the LSB.
- (4). (If the LSB was 0): Repeat Steps(3)(another shift). (If the LSB was 1): Exclusive OR the CRC register with the polynomial value A001 hex (1010 0000 0000 0001), putting the result in the CRC register.
- (5). Repeat Steps (3) and (4) until 8 shifts been performed. When this is done, a complete 8-bit byte will be processed .
- (6). Repeat Steps (2) through (5) for next 8-bit byte of the message, Continue doing this until all bytes have been processed. The final content of the CRC register is the CRC value. Placing the CRC into the message: When the 16-bit CRC (2 8-bit bytes) is transmitted in the message, the Low-order byte will be transmitted first, followed by the high-order byte, For example, if the CRC value is 1241 hex, the CRC-16 Upper put the 41h, the CRC-16 Lower put the 12h.

- **CRC calculation application program**

```
WORD ch_sum ( UBYTE long , UBYTE *rxdbuff )
{
    BYTE i = 0;
    WORD wkg = 0xFFFF;
    while ( long-- )
    {
        wkg ^= rxdbuff++;
        for ( i = 0 ; i < 8; i++ )
        {
            if ( wkg & 0x0001 )
            {
                wkg = ( wkg >> 1 ) ^ 0xa001;
            }
            else
            {
                wkg = wkg >> 1;
            }
        }
    }
    return( wkg );
}
```

3. Error code

ASCII Mode

STX	‘.’
Address	‘0’
	‘1’
Function	‘8’
	‘6’
Exception code	‘5’
	‘1’
LRC Check	‘2’
	‘8’
END	‘CR’
	‘LF’

RTU Mode

SLAVE Address		02H
Function		83H
Exception code		52H
CRC-16	High	C0H
	Low	CDH

Under communication linking, the driver responses the Exception Code and send Function Code AND 80H to main system if there is error happened.

Error Code	Description
51	Function Code Error
52	Address Error
53	Data Amount Error
54	DATA Over Range
55	Writing Mode Error

4. Inverter Control

4.1 Command Data (Readable and Writable)

Register No.	Bit	Content
2500H	Reserved	
2501H		Operation Signal
	0	Operation Command 1 : Run 0 : Stop
	1	Reverse Command 1 : Reverse 0 : Forward
	2	Abnormal 1 : EFO (Note)
	3	Fault Reset 1 : Reset
	4	Jog Forward Command 1 : Jog Forward
	5	Jog Reverse Command 1 : Jog Reverse
	6	Multi-function CommandS1 1 : "ON" 0 : "OFF"
	7	Multi-function CommandS2 1 : "ON" 0 : "OFF"
	8	Multi-function CommandS3 1 : "ON" 0 : "OFF"
	9	Multi-function CommandS4 1 : "ON" 0 : "OFF"
	A	Multi-function CommandS5 1 : "ON" 0 : "OFF"
	B	Reserved
	C	Relay R1 1 : "ON" 0 : "OFF"
	D	Reserved
E~F	Reserved	
2502H	Frequency Command	
2503~251FH	Reserved	

*** Write in zero for Not used BIT, do not write in data for the reserved register.

Note : Bit 2 of 2501H is not for fault indication. EFO is for "external abnormality."

When there is external abnormality, controller may changes the bit value from 0 to 1 through, inverter will stop according to the setting in 07-09, inverter appears "EFO".

4.2 Monitor Data (Only for reading)

Register No.	Bit	Content
2520H	0	Operation state 1 : Run 0 : Stop
	1	Direction state 1 : Reverse 0 : Forward
	2	Inverter operation prepare state 1:ready 0 : unready
	3	Abnormal 1 : Abnormal
	4	DATA setting error 1 : Error
	5-F	Reserved

Register No.	Contents			
2521H	abnormity			
	00	The inverter is normal	25	Inverter over heat during running(OH-C)
	01	Inverter over heat(OH)	26	Stop at 0 speed(STP0)
	02	Over current at stop(OC)	27	Direct start malfunction(STP1)
	03	Under voltage(LV)	28	Control panel emergency stop(STP2)
	04	Over voltage(OV)	29	Keypad operation error)(Err1)
	05	Reserved	30	Parameter setting error(Err2)
	06	External BB(bb)	31	Analog transferred error(Err4)
	07	CPU error by external signal(CTE)	32	Parameter changed during Communication (Err5)
	08	PID feedback signal lost(PDER)	33	Communication failure(Err6) (Note)
	09	EEPROM abnormal(EPR)	34	Parameter setting error(Err7)
	10	Parameters auto measure error(ATER)	35	Restore factory setting error(Err8)
	11	Over Torque(OL3)	36	Reserved
	12	Inverter over load(OL2)	37	Reserved
	13	Motor over load(OL1)	38	Parameters copy error via copy unit (EPR1)
	14	External communication error(EFO)	39	Parameters copy incorrect via copy unit (EPR2)
	15	External stop(E.S)	40	Inverter over speed(OVSP)
	16	Parameters locked(LOC)	41	Input phase lost(PF)
	17	Reserved	42	Horsepower setting error(HPERR)
	18	Over current at constant speed (OC-C)	43	Reserved
	19	Over current during accelerating (OC-A)	44	Motor temperature overheat error(OH4)
	20	Over current during decelerating (OC-D)	45	Motor temperature overheat alarm(OH3)
	21	Over current at starting to run (OC-S)	46	Output current reaches current limit level(CL)
	22	Reserved	47	High Pressure Fault(OPBFT/HIPB)
	23	Under voltage during running(LV-C)	48	Low Pressure Fault(LPBFT/LOPB)
24	Over voltage during decelerating(OV-C)	49	PID Feedback Signal Loss(FBLSS)	

2522H	Sequence input status		
	0	Terminal S1	1 :“ON” 0:“OFF”
	1	Terminal S2	1 :“ON” 0:“OFF”
	2	Terminal S3	1 :“ON” 0:“OFF”
	3	Terminal S4	1 :“ON” 0:“OFF”
	4	Terminal S5	1 :“ON” 0:“OFF”
	5	Reserved	
	Contact output		
	6	Relay R1	1 :“ON” 0:“OFF”
	7	Relay R2	1 :“ON” 0:“OFF”
	9~F	Reserved	

(Note) Err6 error: Inverter gets communication error with external devices.

When inverter gets communication error:

If the controller writes “1” to “2501H bit 2”, inverter appears “EFO” on display.

If the controller does not write “1” to “2501H bit 2”, inverter appears “Err6” on display

Register No.	Content
2523H	Frequency command(100/1Hz)
2524H	Output frequency (100/1Hz)
2525H	Output voltage command (10/1V)
2526H	DC voltage command (1/1V)
2527H	Output current (10/1A)
2528H	Reserved
2529H	Output power (10/1 kW)
252AH	PID feedback (100% / fmax , 10/1%)
252BH	PID input (100% / fmax, 10/1%)
252CH	TM2 AVI input value (1000 / 10V) *1
252DH	TM2 ACI input value (1000 / 10V) *1
252EH	Reserved
252FH	A510s / L510s / E510s identification L510s standard type: 0x0110 L510s PUMP function built-in: 0x0111
2530H	Reserved
2531H	Inverter temperature(10/°C)(temperature of heat sink or IGBT)
2532H	The ratio of inverter and motor rated current (%)

Register No.	Content
2533H	U-phase output current
2534H	V-phase output current
2535H	W-phase output current

4.3 Read the data in the holding register [03H]

Master unit reads the contents of the holding register with the continuous number for the specified quantity.

- Note:1. Limit number of read data, RTU: 37, ASCII:17.
 2. Can only Continuous read the address of the same Group
 3. Read data Quantity≥1.

(Example) Read the SLAVE station No: 01, L510s drive's frequency command.

ASCII Mode

Instruction Message		
3AH	STX	
30H	SLAVE	
31H	Address	
30H	Function	
33H	Code	
32H	Start	
35H		Address
32H		Address
33H	Quantity	
32H		Quantity
35H		Quantity
30H		Quantity
31H	LRC CHECK	
?		LRC CHECK
?	END	
0DH		END
0AH	END	

Response Message (Normal)		
3AH	STX	
30H	SLAVE	
31H	Address	
30H	Function Code	
33H		Function Code
30H	DATA Number	
32H		DATA Number
31H	First holding register	
37H		First holding register
37H		First holding register
30H	LRC CHECK	
?		LRC CHECK
?	END	
0DH		END
0AH	END	

Response(Fault)	
3AH	STX
30H	SLAVE
31H	Address
38H	Function Code
33H	
35H	Error Code
32H	
?	LRC CHECK
?	
0DH	END
0AH	

RTU Mode

Instruction Message		
SLAVE Address		01H
Function Code		03H
Start Address	High	25H
	Low	23H
Quantity	High	00H
	Low	01H
CRC-16	High	7EH
	Low	CCH

Response Message (Normal)		
SLAVE Address		01H
Function Code		03H
DATA Number		02H
First holding register	High	07H
	Low	D0H
CRC-16	High	BBH
	Low	E8H

Response(Fault)		
SLAVE Address		01H
Function Code		83H
Error Code		52H
CRC-16	High	C0H
	Low	CDH

4.4 LOOP BACK testing [08H]

The function code checks communication between MASTER and SLAVE, the Instruction message is returned as a response message without being changed, Any values can be used for test codes or data.

ASCII Mode

Instruction Message		Response Message (Normal)		Response (Fault)	
3AH	STX	3AH	STX	3AH	STX
30H	SLAVE	30H	SLAVE	30H	SLAVE
31H	Address	31H	Address	31H	Address
30H	Function	30H	Function Code	38H	Function
38H	Code	38H		Code	
30H	Test Code	30H	Test Code	32H	Error Code
30H		30H			
30H		37H		LRC CHEC	
30H		35H			
41H	DATA	41H	DATA	0DH	END
35H		0AH			
33H					
37H					
31H	LRC CHECK	31H	LRC CHECK		
42H					
0DH	END	0DH	END		
0AH		0AH			

RTU Mode

Instruction Message			Response Message (Normal)			Response(Fault)		
SLAVE Address	01H		SLAVE Address	01H		SLAVE Address	01H	
Function Code	08H		Function Code	08H		Function Code	88H	
Test Code	High	00H	Test Code	High	00H	Error Code		20H
	Low	00H		Low	00H	CRC-16	High	47H
DATA	High	A5H	DATA	High	A5H		Low	D8H
	Low	37H		Low	37H			
CRC-16	High	DAH	CRC-16	High	DAH			
	Low	8DH		Low	8DH			

4.5 Write holding register [06H]

Specified data are written into the several specified holding registers from the Specified respectively.

(Example)Set SLAVE station No:01, write L510s drive frequency reference 60.0HZ.

ASCII Mode

Instruction Message

3AH	STX
30H	SLAVE
31H	Address
30H	Function
36H	Code
32H	Start Address
35H	
30H	
32H	
31H	DATA
37H	
37H	
30H	
?	LRC CHECK
?	
0DH	END
0AH	

Response Message (Normal)

3AH	STX
30H	SLAVE
31H	Address
30H	Function Code
36H	
32H	Start Address
35H	
30H	
32H	
31H	DATA
37H	
37H	
30H	
?	LRC CHECK
?	
0DH	END
0AH	

Response(Fault)

3AH	STX
30H	SLAVE
31H	Address
38H	Function
36H	Code
35H	Error Code
32H	
?	LRC CHECK
?	
0DH	END
0AH	

RTU Mode

Instruction Message

SLAVE Address	01H	
Function Code	06H	
Start Address	High	25H
	Low	02H
DATA	High	17H
	Low	70H
CRC-16	High	2DH
	Low	12H

Response Message (Normal)

SLAVE Address	01H	
Function Code	06H	
Start Address	High	25H
	Low	02H
DATA	High	17H
	Low	70H
CRC-16	High	2DH
	Low	12H

Response(Fault)

SLAVE Address	01H	
Function Code	86H	
Error Code	52H	
CRC-16	High	C3H
	Low	9DH

4.6 Write in several holding registers [10H]

Specified data are written into the several specified holding registers from the Specified number respectively.

Note:1. Limit number of read data, RTU: 35, ASCII:15.

2. Can only Continuous read the address of the same Group.

3. Read data Quantity≥1.

(Example)Set SLAVE station No:01, L510s drive as forward run at frequency reference 60.0HZ.

ASCII Mode

Instruction Message

3AH	STX
30H	SLAVE Address
31H	
31H	Function Code
30H	
32H	Start Address
35H	
30H	
31H	
30H	Quantity
30H	
30H	
32H	
30H	
34H	DATA Number *
30H	First DATA
30H	
30H	
31H	
31H	Next DATA
37H	
37H	
30H	LRC CHECK
?	
?	
0DH	END
0AH	

Response Message (Normal)

3AH	STX
30H	SLAVE Address
31H	
31H	Function Code
30H	
32H	Start Address
35H	
30H	
31H	
30H	Quantity
30H	
30H	
32H	
30H	
?	LRC CHECK
?	
0DH	END
0AH	

Response(Fault)

3AH	STX
30H	SLAVE Address
31H	
39H	Function Code
30H	
35H	Error Code
32H	
?	LRC CHECK
?	
0DH	END
0AH	

RTU Mode

Instruction Message

SLAVE Address		01H
Function Code		10H
Start Address	High	25H
	Low	01H
Quantity	High	00H
	Low	02H
DATA Number *		04H
First DATA	High	00H
	Low	01H
Next DATA	High	17H
	Low	70H
CRC-16	High	CBH
	Low	26H

Response Message (Normal)

SLAVE Address		01H
Function Code		10H
Start Address	High	25H
	Low	01H
Quantity	High	00H
	Low	02H
CRC-16	High	1BH
	Low	04H

Response(Fault)

SLAVE Address		01H
Function Code		90H
Error Code		52H
CRC-16	High	CDH
	Low	FDH

* DATA Numbers are the actual number X 2

5. Comparison list between parameter and register

Note:

Parameter register No.: GGnnH, "GG" means Group number, "nn" means Parameter number
for example: the address of Pr 08-03 is 0803H. the address of Pr 10-11 is 0A0BH

Register No.	Function	Register No.	Function	Register No.	Function
Group00		Group01		Group02	
0000H	00-00	0100H	01-00	0200H	02-00
0001H	00-01	0101H	01-01	0201H	02-01
0002H	00-02	0102H	01-02	0202H	02-02
0003H	00-03	0103H	01-03	0203H	02-03
0004H	00-04	0104H	01-04	0204H	02-04
0005H	00-05	0105H	01-05	0205H	02-05
0006H	00-06	0106H	01-06	0206H	02-06
0007H	00-07	0107H	01-07	0207H	02-07
0008H	00-08	0108H	01-08	0208H	02-08
0009H	00-09	0109H	01-09	0209H	02-09
000AH	00-10	010AH	01-10	020AH	02-10
000BH	00-11	010BH	01-11	020BH	02-11
000CH	00-12	010CH	01-12	020CH	02-12
000DH	00-13	010DH	01-13	020DH	02-13
000EH	00-14	010EH	01-14	020EH	02-14
000FH	00-15	010FH	01-15	020FH	02-15
0010H	00-16	0110H	01-16	0210H	02-16
0011H	00-17	0111H	01-17	0211H	02-17
0012H	00-18	0112H	01-18	0212H	02-18
0013H	00-19			0213H	02-19
0014H	00-20				

Register No.	Function	Register No.	Function	Register No.	Function
Group03		Group04		Group05	
0300H	03-00	0400H	04-00	0500H	05-00
0301H	03-01	0401H	04-01	0501H	05-01
0302H	03-02	0402H	04-02	0502H	05-02
0303H	03-03	0403H	04-03	0503H	05-03
0304H	03-04	0404H	04-04	0504H	05-04
0305H	03-05	0405H	04-05	0505H	05-05
0306H	03-06	0406H	04-06	0506H	05-06
0307H	03-07	0407H	04-07	0507H	05-07
0308H	03-08	0408H	04-08	0508H	05-08
0309H	03-09	0409H	04-09	0509H	05-09
030AH	03-10	040AH	04-10	050AH	05-10
030BH	03-11	040BH	04-11	050BH	05-11
030CH	03-12	040CH	04-12	050CH	05-12
030DH	03-13	040DH	04-13	050DH	05-13
030EH	03-14	040EH	04-14	050EH	05-14
030FH	03-15	040FH	04-15	050FH	05-15
0310H	03-16			0510H	05-16
0311H	03-17			0511H	05-17
0312H	03-18			0512H	05-18
0313H	03-19			0513H	05-19
0314H	03-20			0514H	05-20
0315H	03-21			0515H	05-21
				0516H	05-22
				0517H	05-23
				0518H	05-24
				0519H	05-25
				051AH	05-26
				051BH	05-27
				051CH	05-28
				051DH	05-29
				051EH	05-30
				051FH	05-31
				0520H	05-32

Register No.	Function	Register No.	Function	Register No.	Function
Group06		Group07		Group08	
0600H	06-00	0700H	07-00	0800H	08-00
0601H	06-01	0701H	07-01	0801H	08-01
0602H	06-02	0702H	07-02	0802H	08-02
0603H	06-03	0703H	07-03	0803H	08-03
0604H	06-04	0704H	07-04	0804H	08-04
0605H	06-05	0705H	07-05	0805H	08-05
0606H	06-06	0706H	07-06	0806H	08-06
0607H	06-07	0707H	07-07	0807H	08-07
0608H	06-08	0708H	07-08	0808H	08-08
0609H	06-09	0709H	07-09	0809H	08-09
060AH	06-10			080AH	08-10
060BH	06-11			080BH	08-11
060CH	06-12			080CH	08-12
060DH	06-13			080DH	08-13
060EH	06-14			080EH	08-14
060FH	06-15			080FH	08-15
0610H	06-16			0810H	08-16
0611H	06-17				
0612H	06-18				
0613H	06-19				
0614H	06-20				
0615H	06-21				
0616H	06-22				
0617H	06-23				
0618H	06-24				
0619H	06-25				
061AH	06-26				
061BH	06-27				
061CH	06-28				
061DH	06-29				
061EH	06-30				
061FH	06-31				
0620H	06-32				
0621H	06-33				
0622H	06-34				
0623H	06-35				
0624H	06-36				
0625H	06-37				
0626H	06-38				
0627H	06-39				

Register No.	Function	Register No.	Function	Register No.	Function
Group09		Group10		Group11	
0900H	09-00	0A00H	10-00	0B00H	11-00
0901H	09-01	0A01H	10-01	0B01H	11-01
0902H	09-02	0A02H	10-02	0B02H	11-02
0903H	09-03	0A03H	10-03	0B03H	11-03
0904H	09-04	0A04H	10-04	0B04H	11-04
0905H	09-05	0A05H	10-05	0B05H	11-05
0906H	09-06	0A06H	10-06	0B06H	11-06
0907H	09-07	0A07H	10-07	0B07H	11-07
0908H	09-08	0A08H	10-08	0B08H	11-08
0909H	09-09	0A09H	10-09	0B09H	11-09
090AH	09-10	0A0AH	10-10	0B0AH	11-10
		0A0BH	10-11	0B0BH	11-11
		0A0CH	10-12	0B0CH	11-12
		0A0DH	10-13	0B0DH	11-13
		0A0EH	10-14	0B0EH	11-14
		0A0FH	10-15	0B0FH	11-15
		0A10H	10-16	0B10H	11-16
		0A11H	10-17	0B11H	11-17
		0A12H	10-18	0B12H	11-18
		0A13H	10-19	0B13H	11-19
		0A14H	10-20	0B14H	11-20
		0A15H	10-21		
		0A16H	10-22		

Register No.	Function	Register No.	Function	Register No.	Function
Group12		Group13		Group14	
0C00H	12-00	0D00H	13-00	0E00H	14-00
0C01H	12-01	0D01H	13-01	0E01H	14-01
0C02H	12-02	0D02H	13-02	0E02H	14-02
0C03H	12-03	0D03H	13-03	0E03H	14-03
0C04H	12-04	0D04H	13-04	0E04H	14-04
0C05H	12-05	0D05H	13-05	0E05H	14-05
		0D06H	13-06	0E06H	14-06
		0D07H	13-07	0E07H	14-07
		0D08H	13-08	0E08H	14-08
				0E09H	14-09
				0E0AH	14-10
				0E0BH	14-11
				0E0CH	14-12
				0E0DH	14-13
				0E0EH	14-14
				0E0FH	14-15
				0E10H	14-16
				0E11H	14-17
				0E12H	14-18
				0E13H	14-19
				0E14H	14-20
				0E16H	14-22
				0E17H	14-23
				0E18H	14-24
				0E19H	14-25
				0E1AH	14-26
				0E1BH	14-27
				0E1CH	14-28
				0E1DH	14-29
				0E1EH	14-30
				0E1FH	14-31
				0E22H	14-34
				0E23H	14-35
				0E25H	14-37
				0E26H	14-38
				0E27H	14-39
				0E47H	14-71
				0E48H	14-72
				0E49H	14-73
				0E4AH	14-74
				0E4BH	14-75
				0E4CH	14-76
				0E4DH	14-77

BACnet Protocol Descriptions

BACnet is in compliance with four-layer of seven-layer structure models in OSI (Open Systems Interconnection) of International Standard Organization (ISO). These four-layer structure models are application layer, network layer, data link layer and physical layer. Besides, BACnet is defined by the view of standard “object” and “property.” All BACnet devices are controlled via the property of objects. Every controller with BACnet devices is considered an object collector so that every controller device can execute different kinds of functions of objects to achieve the communication control and monitor control.

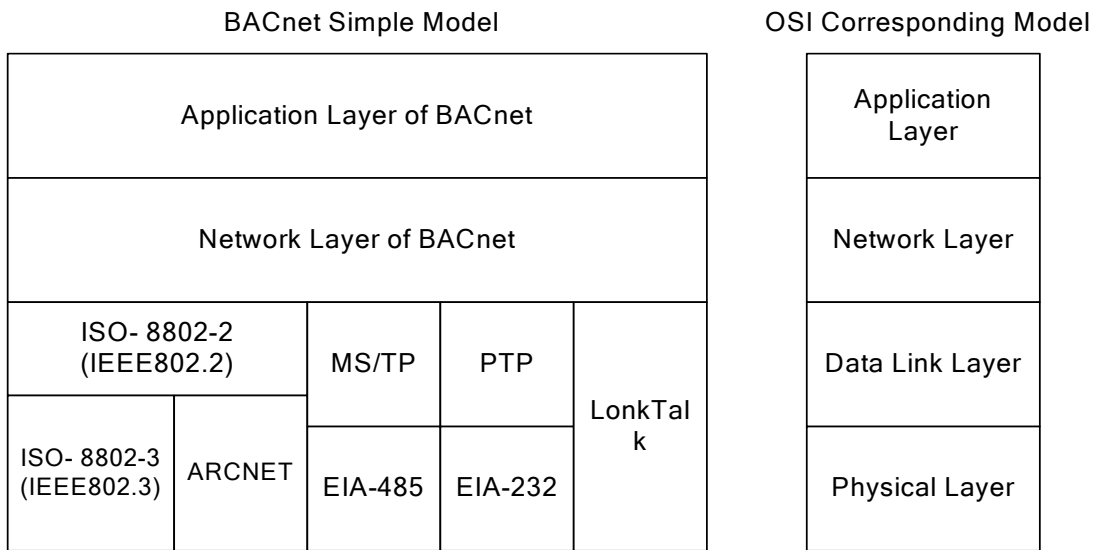

1. BACnet Services

Services provide some commands to save or control information and some functions to achieve the purpose of monitoring and control. Namely, one BACnet device receive certain information or command to complete specific work from other BACnet device so the two devices need to support the same service to complete communication. To complete the exchange of these service messages, these communication requirements are specified in the communication protocol of application layer by BACnet. Thus, services are parts of the communication protocol data unit (PDU) in the application layer and build the communication modes via the relationship of Server – Client. Client will send the message of service requirements to Server and Server needs to respond to Client to execute this service. Refer to the following figure.

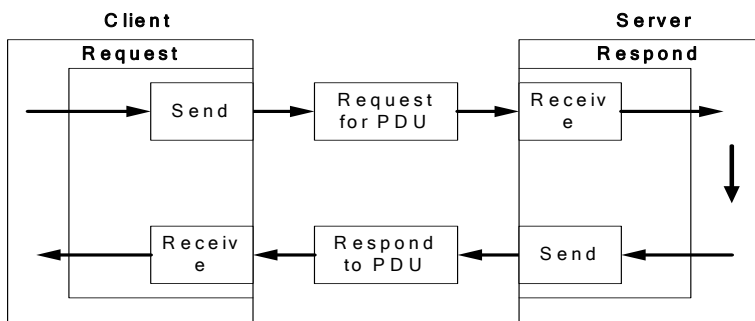

All BACnet devices have the application programs to manage the requirements of device motion and executing services. Take work station for example, the application program needs to keep the display value of every input so it requires sending the service request to the object of other device to update the display value of input. The application program of the device needs to respond to the service requirements. Refer to the following figure.

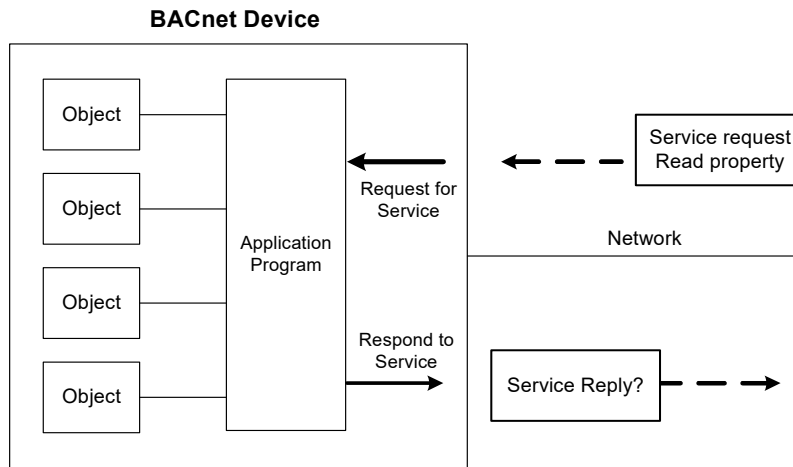

2. BACnet Protocol Structure

BACnet is the communication protocol by way of protocol stack so the packet is composed of stacked layer types. Refer to the following figure.

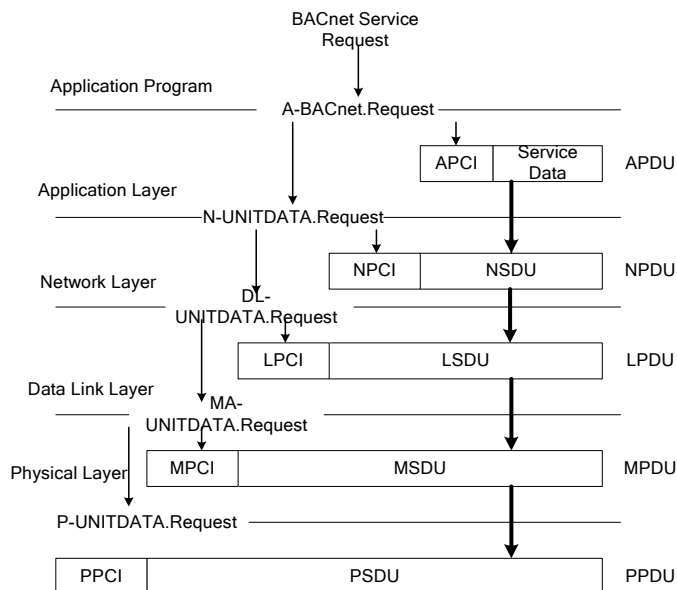

When application program sends the BACnet service request for the packet, it requires requesting for executing BACnet request program in the application layer via application program interface. The requirements of the program are sent to the application layer and application protocol data unit (APDU) consists of Application Protocol Control Information (APCI) and Service Data of application program. Then APDU passes its messages downward to BACnet request program in the network layer. APDU becomes Network Layer Protocol Data Unit (NPDU) composed of Network Service Data Unit (NSDU) and Network Protocol Control Information (NPCI). And so forth for the data link layer and physical layer to complete the full service for the packet.

3. BACnet Specifications

Inverter L510s model is built-in standard BACnet MS/TP communication protocol structure to meet the demand of automatic communication equipment. Control or monitor L510s via BACnet to be allowable to read and modify specific parameter. L510s includes the following supports of standard objects:

- Inverter Objects
- Analog Input
- Digital Input
- Analog Output
- Digital Output
- Analog Value
- Digital Value

Refer to Table 3.1 for L510s supporting the property information of object classification. User can collect related properties of objects required via the dedicated communication software of BACnet to give control or monitor command for each object.

Table 3.1 Object and property supporting list

Proerty	Inverter (DEV)	Analog Input (AI)	Analog Output (AO)	Analog Value (AV)	Digital Input (BI)	Digital Output (BO)	Digital Value (BV)
Object_Identifier	V	V	V	V	V	V	V
Object_Name	V	V	V	V	V	V	V
Object_Type	V	V	V	V	V	V	V
System_Status	V						
Vendor_Name	V						
Vendor_Identifier	V						
Model_Name	V						
Firmware_Revision	V						
Applocation_Software_Supported	V						
Protocol_Version	V						
Protocol_Revision	V						
Protocol_Services_Supported	V						
Protocol_Object_Type_Supported	V						
Object_List	V						
Max_APDU_Length_Accepted							
Segmentation_Supported							
APDU_Timeout							
Number_Of_APDU_Retries							
Max_Masters	V						
Max_Info_Frames	V						
Device_Address_Binding							
Location	V						
Presnent_Value		V	V	V	V	V	V
Status_Flags							
Event_State							
Reliability							
Out_Of_Service							
Units		V	V	V			
Priority_Array							
Relinquish_Default							
Polarity							
Inactive_Text							
Active_Text							

4. BACnet Object Properties

This section provides the predetermined configuration of the inverter. User can achieve the optimized situation at any necessary modification.

Refer to Table 4.1 for the property information of inverter objects and user can learn the inverter messages from the inverter objects.

Refer to Table 4.2 ~ Table 4.7 for the related object information that inverter supports. User can control/ read each object with the application requirements.

Table 4.1 – Inverter property list

Property	Inverter
Object_Identifier	DEV
Object_Name	VFD
Object_Type	8
System_Status	0
Vendor_Name	TECO L510s
Vendor_Identifier	461
Model_Name	TECO.Inc
Firmware_Revision	0.14
Applocation_Software_Supported	0.14
Protocol_Version	1
Protocol_Revision	5
Protocol_Services_Supported	{ readProperty , writeProperty , who is }
Protocol_Object_Type_Supported	{ Analog_Input , Analog_Output, Analog_Value Binary_Input, Binary_Output, Binary_Value, Device}
Max_Masters	127
Max_Info_Frames	1
Location	R.O.C

Table 4.2 Analog input property list (READ)

No.	Object Name	Description	Unit	Classification	Range
AI0	TM2 AVI	AVI input	Percent	R	0 - 100
AI1	TM2 ACI	ACI input	Percent	R	0 - 100
AI2	Error code	Recent fault message	No Units	R	0 -43
AI3	Freq cmd	Frequency command	HZ	R	0 - 599
AI4	Frequency	Output frequency	HZ	R	0 -599
AI5	Current	Output current	Amps	R	
AI6	Control Mode	Control mode	No Units	R	0 - 1
AI7	Motor R-Volt	Motor rated voltage	Volt	R	
AI8	Motor R-HP	Motor rated power	horsepower	R	
AI9	Motor R-RPM	Motor rated rotation speed	rpm	R	
AI10	Motor R-Hz	Motor rated frequency	HZ	R	
AI11	CarrierFreq	Carrier frequency	KiloHertz	R	1 - 16
AI12	Comm Station	INV communication station	No Units	R	1 - 32
AI13	BaudRate	Baudrate setting	No Units	R	0 - 3
AI14	BacnetSel	Communication mode selection	No Units	R	0 - 2
AI15	DevInstance	Inverter number	No Units	R	1 - 254

Table 4.3 – Analog output property list (READ/ WRITE)

No.	Object Name	Description	Unit	Classification	Range
A00	Set Frequency	Frequency command	HZ	R/W	0 - 599
A01	AO	Output voltage	Volt	R	0 - 10
A03	Motor R-Amp	Motor rated current	Amps	R/W	0-65535
A04	PwrL Sel	Momentary stop and restart selection	No Units	R	0 - 1
A05	RestartSel	Number of Fault Auto-Restart Attempts	No Units	R	0 - 10
A06	RestartDelay	Fault Auto-Restart Time	seconds	R	0 - 800
A07	FreqCommand1	Speed frequency setting-stage 0	HZ	R/W	0 - 599
A08	FreqCommand2	Speed frequency setting-stage 1	HZ	R/W	0 - 599
A09	FreqCommand3	Speed frequency setting-stage 2	HZ	R/W	0 - 599
A010	FreqCommand4	Speed frequency setting-stage 3	HZ	R/W	0 - 599
A011	FreqCommand5	Speed frequency setting-stage 4	HZ	R/W	0 - 599
A012	FreqCommand6	Speed frequency setting-stage 5	HZ	R/W	0 - 599
A013	FreqCommand7	Speed frequency setting-stage 6	HZ	R/W	0 - 599

No.	Object Name	Description	Unit	Classification	Range
AO14	FreqCommand8	Speed frequency setting-stage 7	HZ	R/W	0 - 599
AO23	RunMode	Main run command source selection	No Units	R/W	0 - 2
AO24	ReverseOper	Direction locked command	No Units	R/W	0 - 1
AO25	StoppingSel	Stop modes selection	No Units	R/W	0 - 1
AO26	FrequenceComm	Main frequency command source selection	No Units	R/W	0 - 6
AO27	FreqUpperLim	Upper limit frequency	HZ	R/W	0.01 - 599
AO28	FreqLowerLim	Lower limit frequency	HZ	R/W	0 - 598.99
AO29	Acc Time1	Acceleration time 1	seconds	R/W	0.1 - 3600
AO30	Dec Time1	Deceleration time 1	seconds	R/W	0.1 - 3600

Table 4.4 Analog value property list (READ/ WRITE)

No.	Object Name	Description	Unit	Classification	Range
AV0	PID – P Gain	Proportional gain (P)	No Units	R/W	0 - 10
AV1	PID – I Time	Integral time (I)	No Units	R/W	0 - 100
AV2	PID – D Time	Differential time (D)	No Units	R/W	0 - 10

Table 4.5 Digital input property list (READ)

No.	Object Name	Description	Unit	Classification	Range
BI0	Run/Stop	Operation status	Stop / Run	R	0 - 1
BI1	Direction	Operation direction	FWD/REV	R	0 - 1
BI2	ststus	Inverter status	OK/Fault	R	0 - 1
BI3	Abnormal	Error occurs	Close/Open	R	0 - 1
BI4	DI_1 status	S1 status	Close/Open	R	0 - 1
BI5	DI_2 status	S2 status	Close/Open	R	0 - 1
BI6	DI_3 status	S3 status	Close/Open	R	0 - 1
BI7	DI_4 status	S4 status	Close/Open	R	0 - 1
BI8	DI_5 status	S5 status	Close/Open	R	0 - 1

Table 4.6 Digital output property list (READ/ WRITE)

No.	Object Name	Description	Unit	Classification	Range
BO0	RY1 status	Relay output 1 status	Close/Open	R	0 - 1

Table 4.7 Digital value property list (READ/ WRITE)

No.	Object Name	Description	Unit	Classification	Range
BV0	RUN/STOP	RUN/STOP	Stop / Run	R/W	0 - 1
BV1	FWD/REV	FWD/REV	FWD/REV	R/W	0 - 1

Appendix 4: JN5-CM-USB instruction manual

1. Model number and specification

1.1 Model number and function instruction

JN5-CM-USB is a RS232 USB type to RS485 converter. It is used for communication between PC and inverter.

1.2 Dimensions of JN5-CM-USB

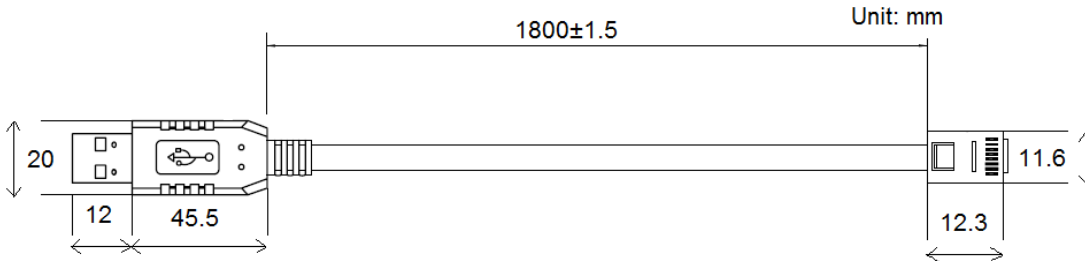

1.3 Connection between inverter and computer.

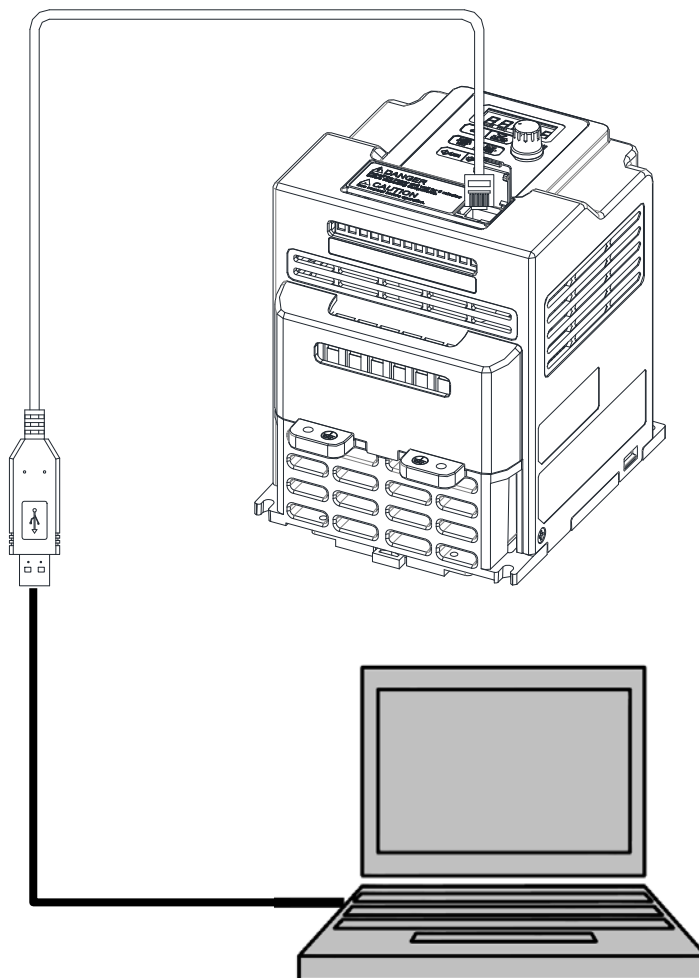

2. USB Interface Cable Pin Definition

2.1 RS232/USB at PC side.

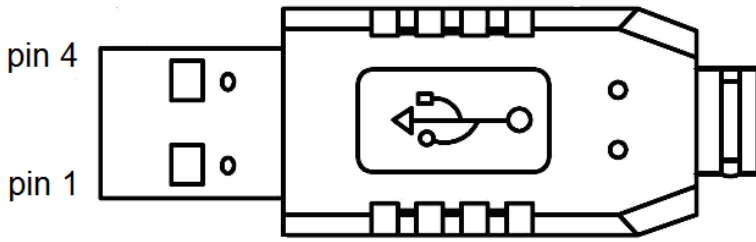

RS485/RJ45 connector at inverter side.

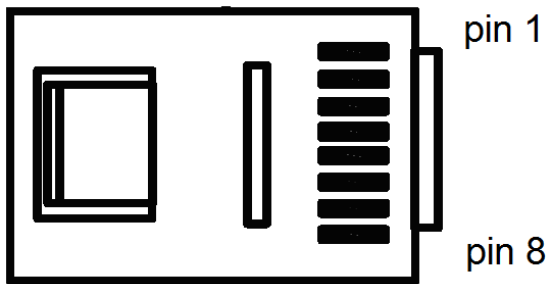

2.2 RS485/RJ45 Pin Definition.

Pin No.	Pin 1	Pin 2	Pin 3	Pin 4	Pin 5	Pin 6	Pin 7	Pin 8
Define	A	B	NC	NC	NC	NC	VCC	GND

Note:

1. A/B phase signal (Pin1&Pin2) is differential mode data signal of RS485.
2. VCC&GND is the +5Vdc power supply provided by inverter internal power source.

3. Notice

- 3-1. Please turn off the power before you connect the cable..
- 3-2. Once inverter is powered off during communication. PC software will show “communication error”.
- 3-3. If there is any error during communication, please check the wiring connection and restart the pc software.

Appendix 5: L510s accessories

Accessories	Model	Function
510 Keypad extension cable (1M)	JN5-CB-01M	Keypad extension cable for 510 series
510 Keypad extension cable (2M)	JN5-CB-02M	
510 Keypad extension cable (3M)	JN5-CB-03M	
510 Keypad extension cable (5M)	JN5-CB-05M	
510 series copy module	JN5-CU	<ol style="list-style-type: none"> 1. Duplicating parameters setting from one inverter to another inverter 2. As a remote keypad to be used
Profibus DP communication module	JN5-CM-PDP	For connection of Profibus-DP communication protocol
TCP-IP communication module	JN5-CM-TCPIP	For connection of TCP-IP communication protocol
DeviceNet communication module	JN5-CM-DNET	For connection of DeviceNet communication protocol
CANopen communication module	JN5-CM-CAN	For connection of CANopen communication protocol
EtherNet/IP communication module	JN5-CM-EIP	For connection of EtherNet/IP communication protocol
RJ45 to USB connection cable (1.8M)	JN5-CM-USB	Using the TECO exclusive PC-software cable
EMC Grounding kit(Frame 1)	JN5-GK-L01	to enhance the EMC ability by enlarge the ground
EMC Grounding kit(Frame 2)	JN5-GK-L02	
Din rail (Frame 1)	JN5-DIN-L01	mounting rails to support the drive
Din rail (Frame 2)	JN5-DIN-L02	
Remote keypad	JN5-OP-L01	External LED keypad (For L510s only)

Appendix 6: Manufacturer's Statement for L510s series

L510s efficiency according to IEC/EN 61800-9-2

Drive models: L510s series, please refer to the table below for the model list

Efficiency class: IE2

Nominal voltage: Please refer to the tabel below

Nominal frequency: 50Hz

Nominal power: Please refer to the tabel below

Motor control: V/f, vector

Nominal current: Please refer to the tabel below

Nominal apparent power: Please refer to the tabel below

Maximum operating temperature: 50°C for frame 2~4,
40°C for frame 1

CDM losses and efficiency (calculated with default settings) point: As the picture right

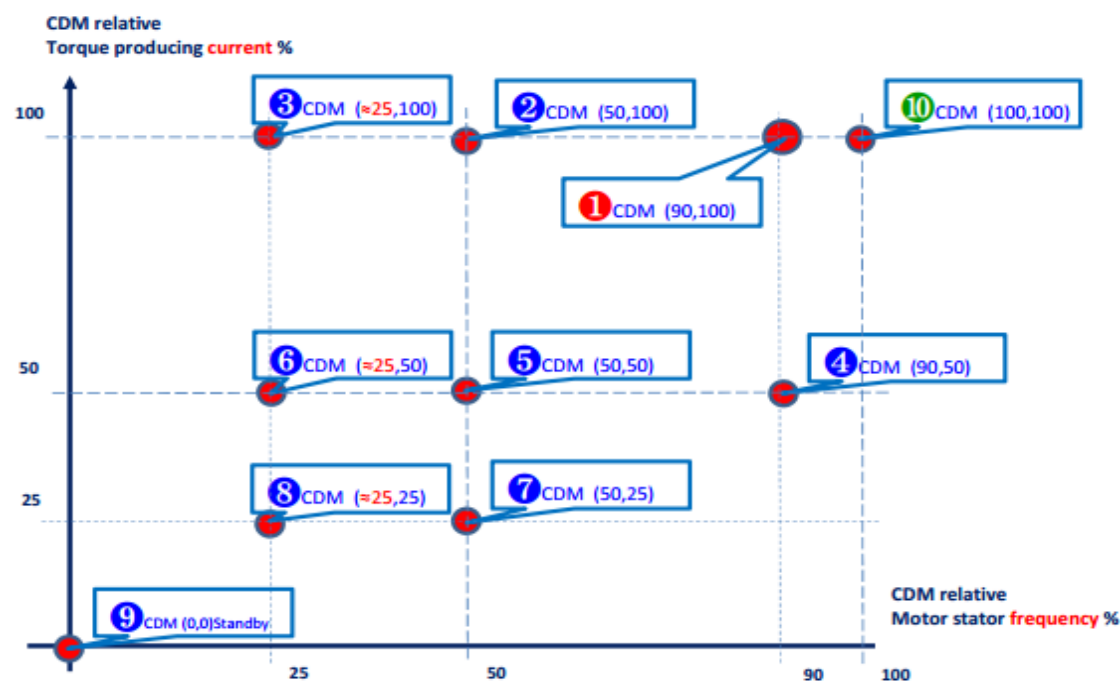

Manufacturer: TECO Electric & Machinery CO., LTD. — 10F, No.3-1, Park St., Nan-Kang, Taipei, 115603, Taiwan

EU contact: MOTOVARIO S.p.A — Via Quattro Passi 1/3 — 41043 — Formigine (MO) — ITALY. MOTOVARIO EORI number: IT02569681204

CDM losses and efficiency table

Frame	Model	Nominal voltage (V)	Nominal current (A)	Nominal power (kW)	Nominal apparent power (KVA)	⑨		⑧		⑥		③		⑦		⑤		②		④		①		⑩		
						CDM STANDBY LOSS	CDM (25,25) or (*12Hz,25)	CDM(25;50) or (*12Hz,50)	CDM(25; 100) or (*12Hz,100)	CDM (50,25)	CDM (50,50)	CDM (50,100)	CDM (90,50)	CDM (90,100)	CDM (100,100)											
						p Loss(W)	p Loss(W)	η(%)	p Loss(W)	η(%)	p Loss(W)	η(%)	p Loss(W)	η(%)	p Loss(W)	η(%)	p Loss(W)	η(%)	p Loss(W)	η(%)	p Loss(W)	η(%)	p Loss(W)	η(%)	p Loss(W)	η(%)
110V 1phase																										
1	L510-1P2-SH1-X	110	1.8	0.2	0.7	8.0	14	60.7	15	69.9	17	78.1	15	75.5	16	81.9	19	86.9	18	87.5	24	90.3	26	90.6		
1	L510-1P5-SH1-X	110	2.6	0.4	1.0	8.0	19	62.9	19	71.7	23	78.9	20	76.9	21	82.9	27	87.1	26	87.8	36	89.9	40	90.2		
2	L510-101-SH1-X	110	4.3	0.75	1.7	11.0	24	64.6	28	75.2	37	80.7	25	78.3	31	85.1	44	88.0	38	89.2	63	90.2	69	90.3		
220V 1phase																										
1	L510-2P2-SH1(F)-X	220	1.8	0.2	0.7	8.0	15	74.6	15	81.6	18	87.2	15	85.6	16	89.8	19	93.0	18	93.6	28	94.1	23	95.6		
1	L510-2P5-SH1(F)-X	220	2.6	0.4	1.0	8.0	20	76.3	20	82.8	24	87.7	21	86.6	21	90.5	26	93.2	24	93.9	32	95.3	34	95.6		
1	L510-201-SH1(F)-X	220	4.3	0.75	1.7	8.0	23	79.4	27	86.3	36	89.5	23	88.5	28	92.5	41	94.1	33	95.0	51	95.8	55	96.0		
2	L510-202-SH1(F)-X	220	7.5	1.5	3.0	11.0	35	81.2	42	87.5	58	90.3	36	89.6	45	93.1	66	94.4	53	95.3	102	95.2	93	96.1		
2	L510-203-SH1(F)-X	220	10.5	2.2	4.0	11.0	50	80.9	61	87.1	86	89.8	52	89.4	66	92.8	99	94.1	80	95.0	152	94.9	144	95.6		
440V 3phase																										
2	L510-401-SH3(F)-X	380	2.3	0.75	1.7	13.9	25	76.4	27	84.9	34	89.5	25	87.0	28	92.0	35	94.5	29	95.3	37	96.7	37	97.0		
2	L510-402-SH3(F)-X	380	3.8	1.5	2.9	13.9	33	80.0	38	87.0	50	90.5	34	89.2	39	93.2	52	95.0	41	95.9	66	96.4	56	97.2		
2	L510-403-SH3(F)-X	380	5.2	2.2	4.0	13.9	36	83.3	42	89.2	57	92.0	37	91.1	44	94.4	59	95.8	46	96.6	64	97.4	65	97.6		
3	L510-405-SH3(F)	380	9.2	3.7	7.0	16.9	58	84.6	70	89.9	96	92.3	60	91.8	72	94.7	100	96.0	76	96.8	108	97.5	111	97.7		
3	L510-408-SH3(F)	380	13	5.5	9.9	16.9	60	88.4	77	92.0	125	93.3	62	93.9	81	95.8	137	96.4	91	97.3	165	97.5	174	97.7		
4	L510-410-SH3(F)	380	17.5	7.5	13.3	25.9	94	86.6	121	90.7	198	92.2	97	92.9	128	95.1	216	95.8	142	96.9	258	97.2	271	97.3		
4	L510-415-SH3(F)	380	24	11	18.3	25.9	120	87.5	157	91.2	265	92.4	124	93.37	166	95.3	291	95.8	188	97.0	359	97.1	382	97.2		
220V 3phase																										
1	L510-2P2-SH3-X	220	1.8	0.2	0.7	8.0	15	74.7	15	81.6	17	87.3	15	86	16	90.0	18	93.2	17	93.9	20	95.8	20	96.1		
1	L510-2P5-SH3-X	220	2.6	0.4	1.0	8.0	20	76.4	20	82.9	24	87.8	20	87	21	90.7	25	93.5	22	94.3	28	95.9	29	96.2		
1	L510-201-SH3-X	220	4.3	0.75	1.7	8.0	22	79.4	26	86.4	36	89.6	23	89	28	92.7	39	94.4	30	95.4	44	96.4	46	96.6		
2	L510-202-SH3-X	220	7.5	1.5	3.0	11.0	35	81.3	41	87.6	57	90.4	36	90	44	93.3	62	94.8	48	95.8	73	96.5	77	96.7		
2	L510-203-SH3-X	220	10.5	2.2	4.0	11.0	50	81.0	60	87.2	84	90.0	51	90	63	93.1	92	94.5	70	95.6	109	96.3	114	96.5		
3	L510-205-SH3	220	17.5	3.7	6.7	11.9	58	85.9	70	90.6	100	92.7	60	92	75	95.0	110	96.0	84	96.8	128	97.4	134	97.5		
4	L510-208-SH3	220	26	5.5	9.9	23.0	78	87.1	100	91.0	164	92.5	81	93	107	95.2	183	95.8	123	96.9	231	97.0	246	97.2		
4	L510-210-SH3	220	35	7.5	13.3	23.0	104	87.2	137	90.9	235	92.1	108	93	146	95.1	261	95.6	169	96.8	310	97.1	348	97.0		



TECO Electric & Machinery Co., Ltd.

10F., No.3-1, Yuancyu St., Nangang District,

Taipei City 115, Taiwan

Tel : +886-2-6615-9111

Fax : +886-2-6615-0933

<http://industrialproducts.teco.com.tw/>



Distributor

4KA72X638T51 Ver:08 2025.05

This manual may be modified when necessary because of improvement of the product, modification, or changes in specifications, This manual is subject to change without notice.