



# *JSDG3*

TECO AC Servo System



# JSDG3 Series

Next-Generation AC servo system

## 4 Key Enhancements

### 1 High Performance

---

- Speed loop bandwidth up to 3.2kHz
- Support 17/23bit encoders
- Input/output pulses up to 4Mpps
- Up to 350% overload capacity

### 2 Intelligence

---

- Automatic gain adjustment
- Resonance suppression function
- Integrated PC-link intelligent tuning software
- Built-in drive lifetime prediction function

### 3 Versatility

---

- Position/speed/torque/CANopen multi-control mode in one
- Turret mode control
- Gantry synchronous control
- Electronic CAM tracking/flying shear control
- Full closed-loop control
- Linear motor control

### 4 High Reliability

---

- Independent cooling duct design
- IP65/IP67 waterproof and dustproof protection



## High resolution encoder to enhance positioning accuracy

Support  
17/23bit  
encoder

- ◆ Encoder resolution increased to 23bit (8,388,608 pulse/rev).
- ◆ Compatible with incremental/absolute encoder types.
- ◆ Significantly improve the positioning accuracy of the equipment.

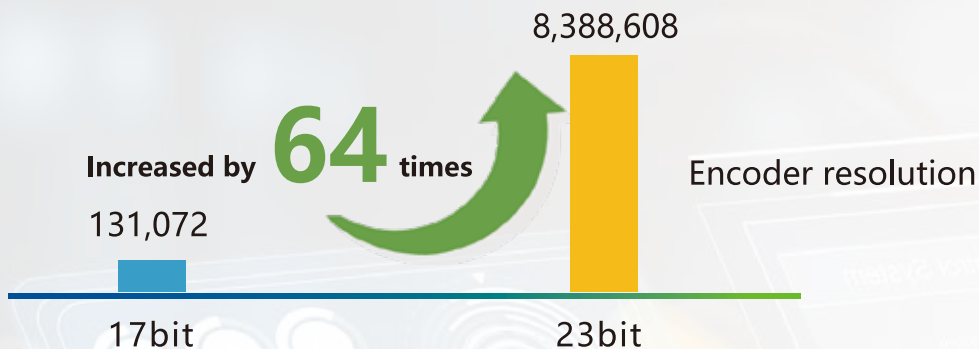

## High bandwidth response

The G3 next-generation control core significantly enhances current noise immunity and frequency response

- ◆ Compared to the previous G2S series, the G3-E series achieves a bandwidth upgrade to 3.2kHz, enabling faster command tracking and significantly reduced positioning settling time.
- ◆ Designed for ultra-high-speed and ultra-precision control, it maximizes the performance of mechanical systems and improves overall efficiency.

High  
bandwidth  
response  
3.2 kHz

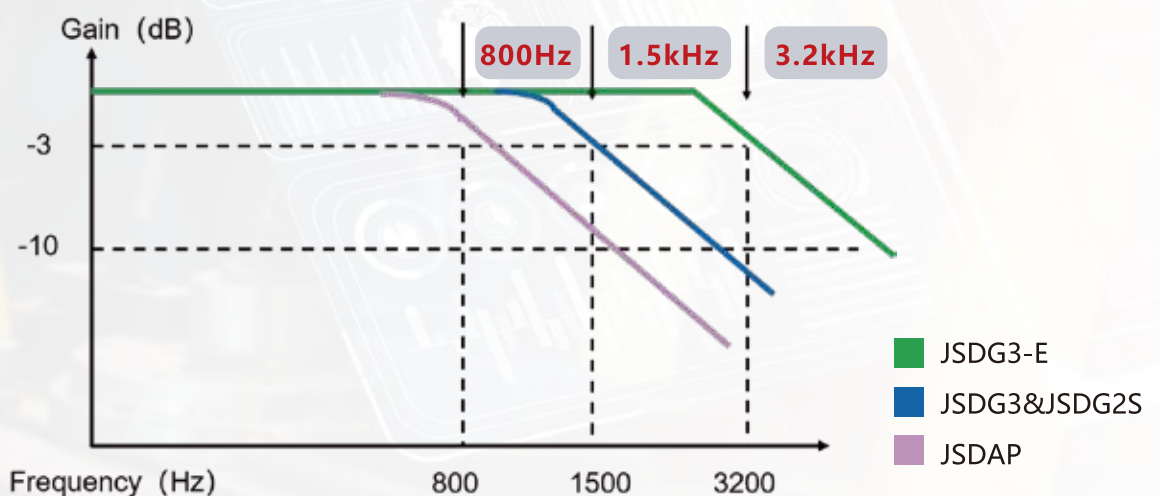

## Auto-tuning

- ◆ The new auto gain tuning algorithm can automatically adjust gain parameters to match the optimal operating state of the equipment.
- ◆ Tuning path can be selected based on the machine's characteristics and operating conditions.
- ◆ Both front panel keypad and PC software provide convenient access to auto-tuning functions.

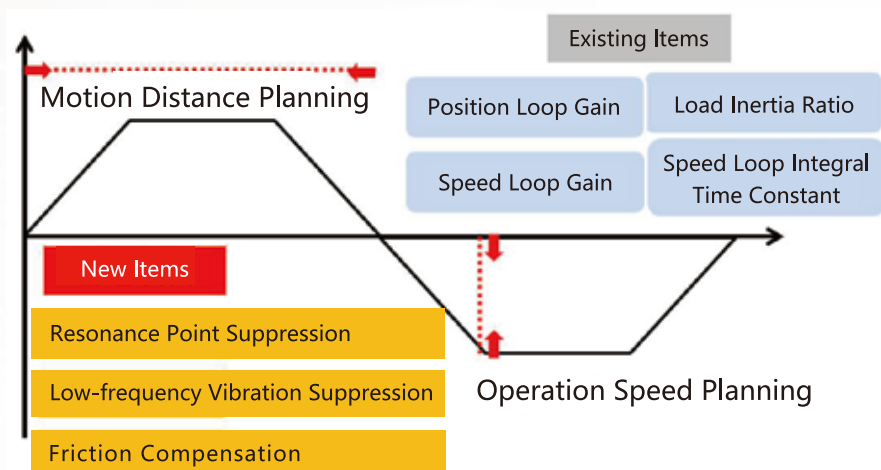

## High-and low-frequency resonance suppression

- ◆ Equipped with a new resonance suppression algorithm and a user-friendly PC-Link interface, the system allows for fast and easy tuning of low-stiffness mechanical structures.
- ◆ Multiple sets of high- and low-frequency suppression functions are available, effectively reducing vibration and noise caused by mechanical resonance.

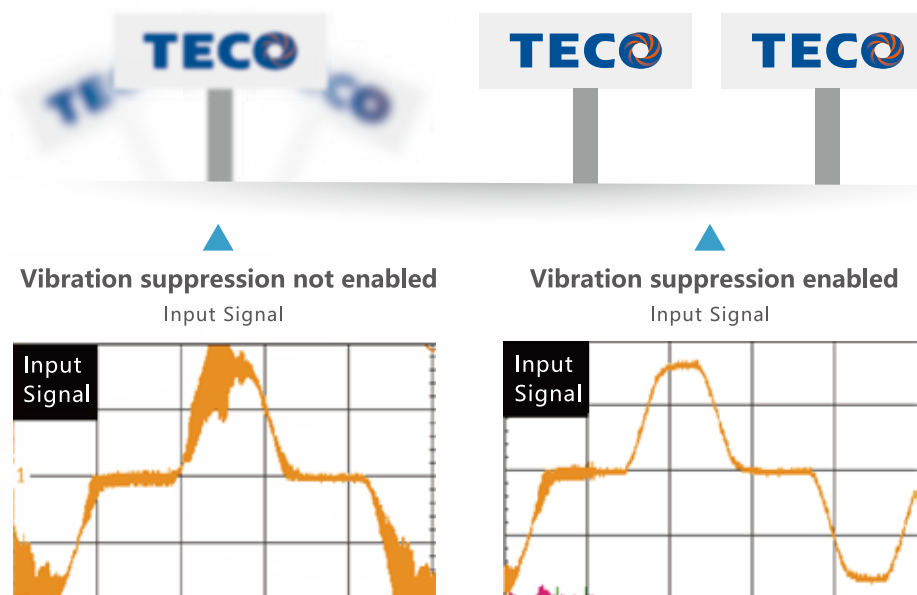

Five sets of high-frequency suppression are available, with adjustable frequencies from 0 to 2000 Hz. Three sets of low-frequency suppression are available, with adjustable frequencies from 1 to 100 Hz.

## Turret mode control

- ◆ Servo drive built-in turret mode, take the shortest path of intelligent tool change to achieve the highest benefit.

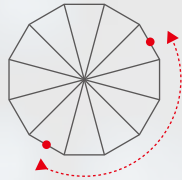

Intelligent shortest-path tool changing to achieve the highest benefit



## Gantry synchronous control

- ◆ The servo drive has built-in gantry synchronous function, which can realize the synchronization of the two axes even when the load of the two axes is different.
- ◆ Suitable for gantry structure system (such as laser cutting, stone cutting...etc).

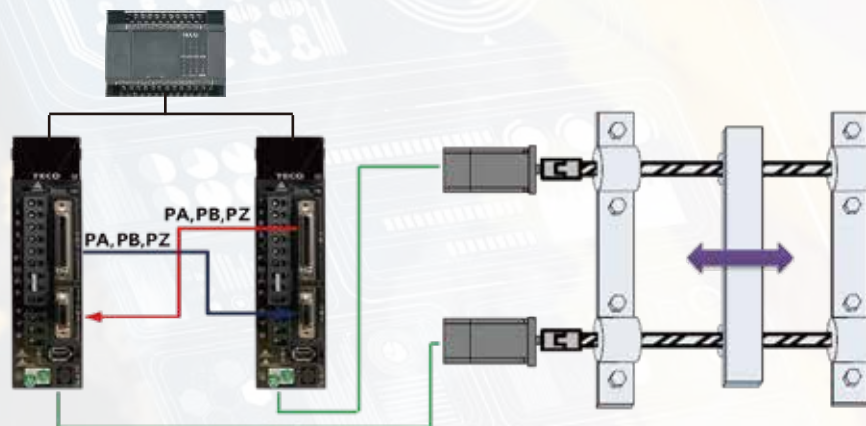

## Electronic CAM tracking and flying shear control

- ◆ A virtual cam function is realized by software, enabling precise synchronization between the master (feeding) axis and the slave (cutting) axis. This function simulates the effect of a physical cam between the two axes.
- ◆ It is ideal for applications such as flying shear, tracking shear, and other master-slave motion control systems.

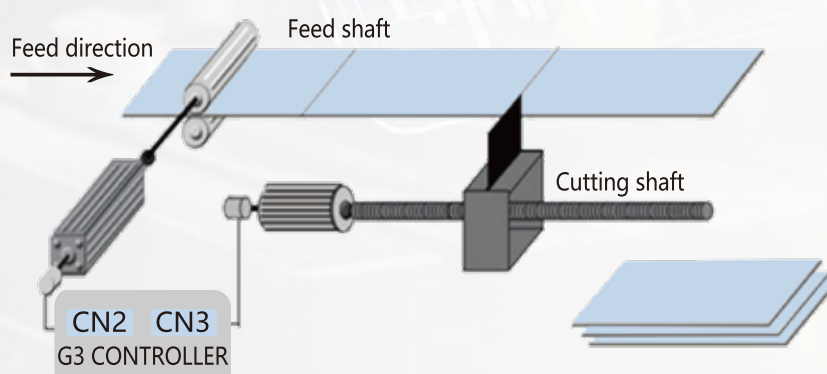

## Full closed-loop control

- ◆ The servo drive supports the full closed-loop function, which can effectively eliminate the position error caused by mechanical clearance and other factors, and greatly improve the operating accuracy of the system.

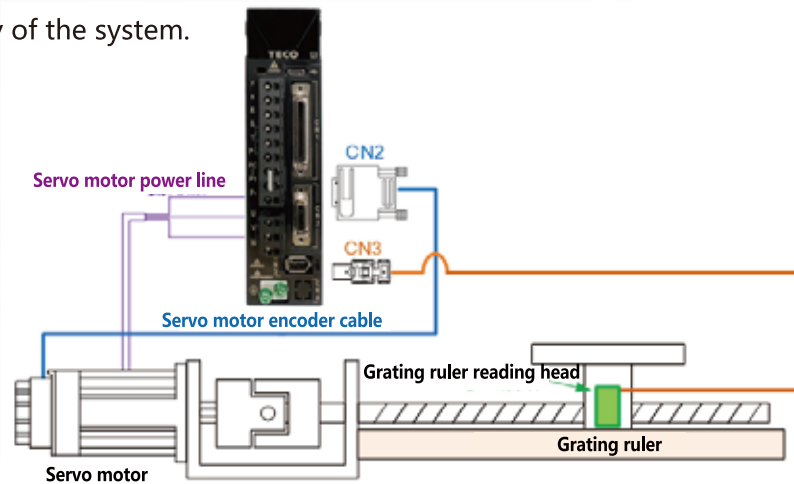

## Support linear motor

- ◆ It can support encoders such as A/B/Z phase grating and magnetic gate.
- ◆ Can support with/without pole position (Hall) signal automatic detection.

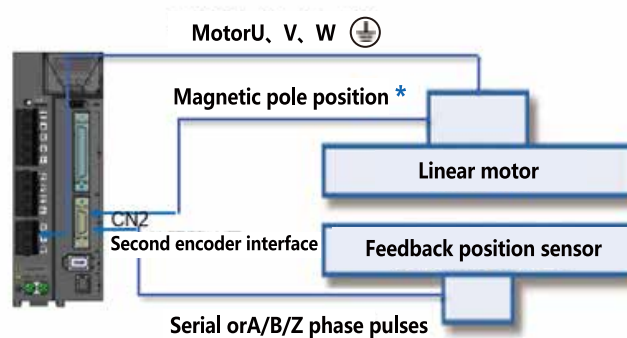

\*Don't need to connect, when the magnetic pole position is automatically detected

## Support Type-C interface is more convenient

- ◆ The new Type-C interface is designed to meet the needs of intelligent system tuning.

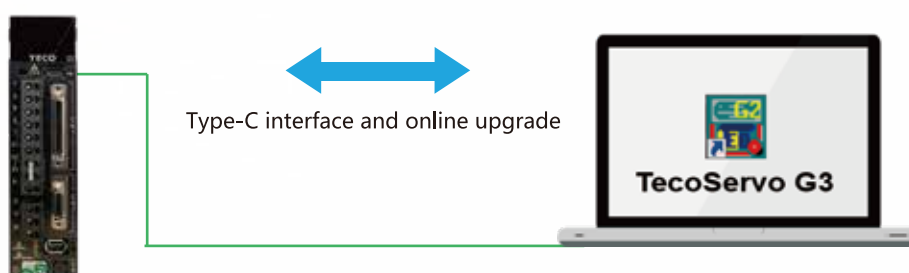

## IP67 Higher protection level of motor

- ◆ With in-line connector, in line with IP67 protection class, can be applied to water vapor, oil and other applications.



## 22% Shorter of motor body length

- ◆ The motor adopts a new 5-pole-pair design to achieve higher power density, resulting in significantly reduced motor size and better adaptability to compact installation spaces. Help equipment to achieve miniaturization and lightweight.
- ◆ This contributes to the miniaturization and lightweighting of equipment. The overall motor length has been reduced by 22% compared to the previous generation.

PUC04 series

PEC04 series



22% shorter

\* Take PEC series 400W as an example

## Drive independent cooling duct design, environmental resistance, reliable

- ◆ Independent air duct design, greatly reduce the main capacitance and internal temperature, avoid dust, foreign matter into the control circuit, extend the drive life.

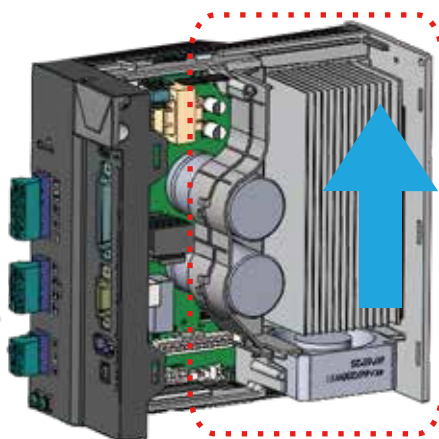

The main capacitor life is improved

40%

\* Ambient temperature 40°C, 80% load current condition.

## Battery easy installation

- ◆ Now featuring absolute encoder support and a redesigned battery slot for faster and more convenient installation.
- ◆ A newly added lifetime prediction function allows users to schedule maintenance in advance, reducing the risk of unplanned shutdowns and enhancing equipment reliability.

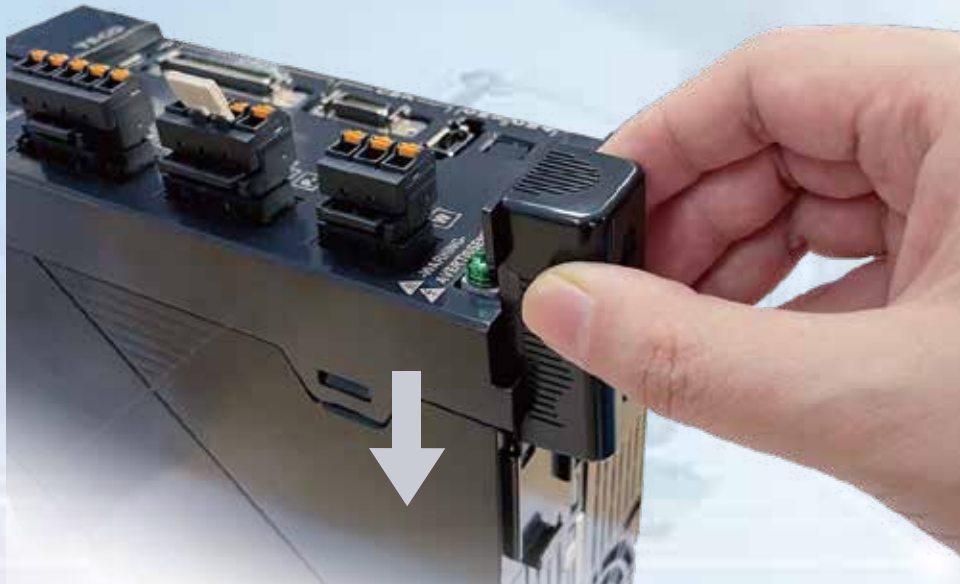

## Build-in drive lifetime prediction function

◆

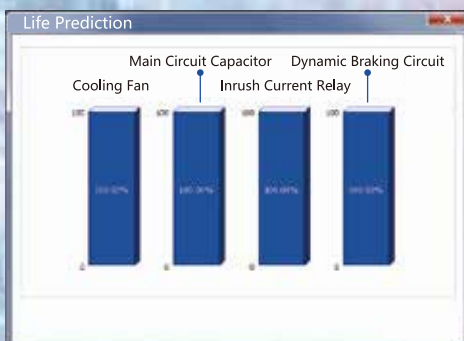

### Color Indicator Description

Remaining life <10% : Red background with gray text

Remaining life 10%~29.99% :  
Yellow background with blue text

Remaining life 30%~100% :  
Blue background with white text

No device detected: Gray background with black text

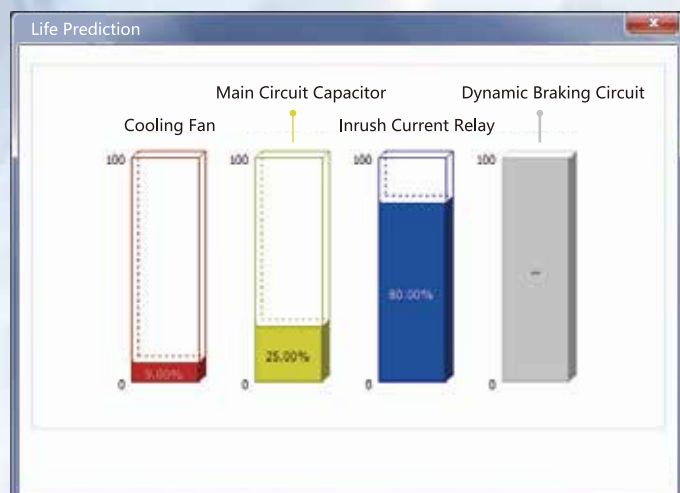

## Intelligent tuning software “PC-link”

- ◆ PC-link software adds an instructional parameter setting feature to make it easy for customers to get started with the drive.

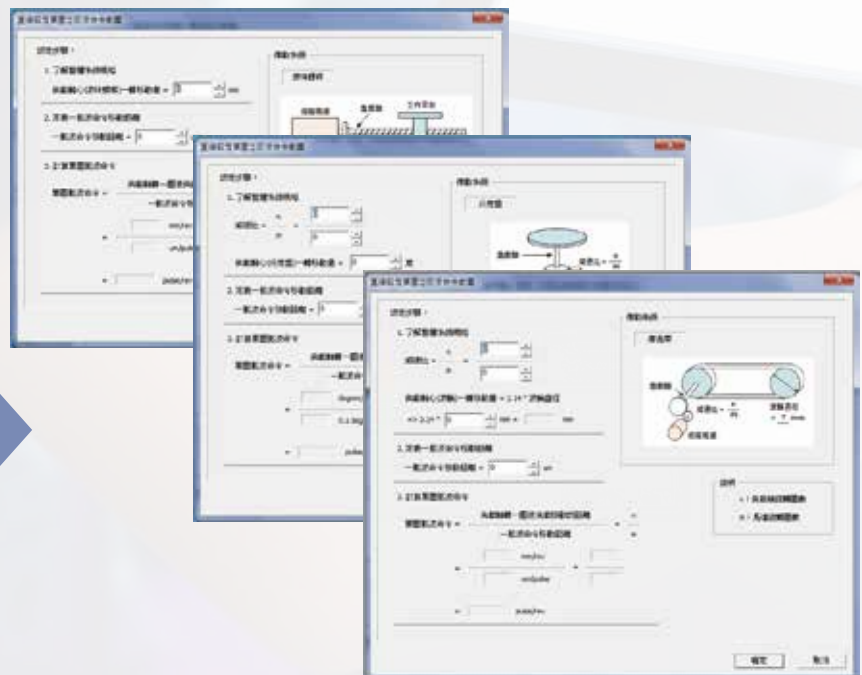
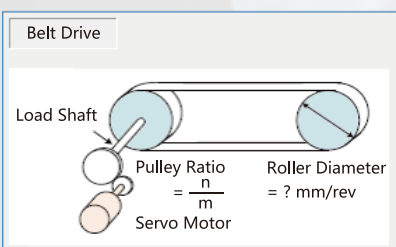
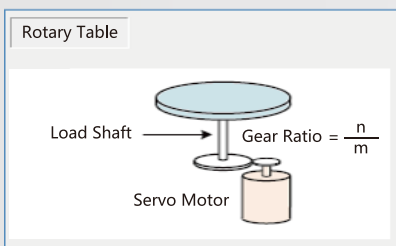
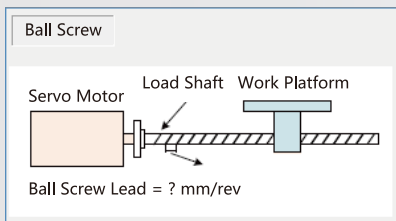
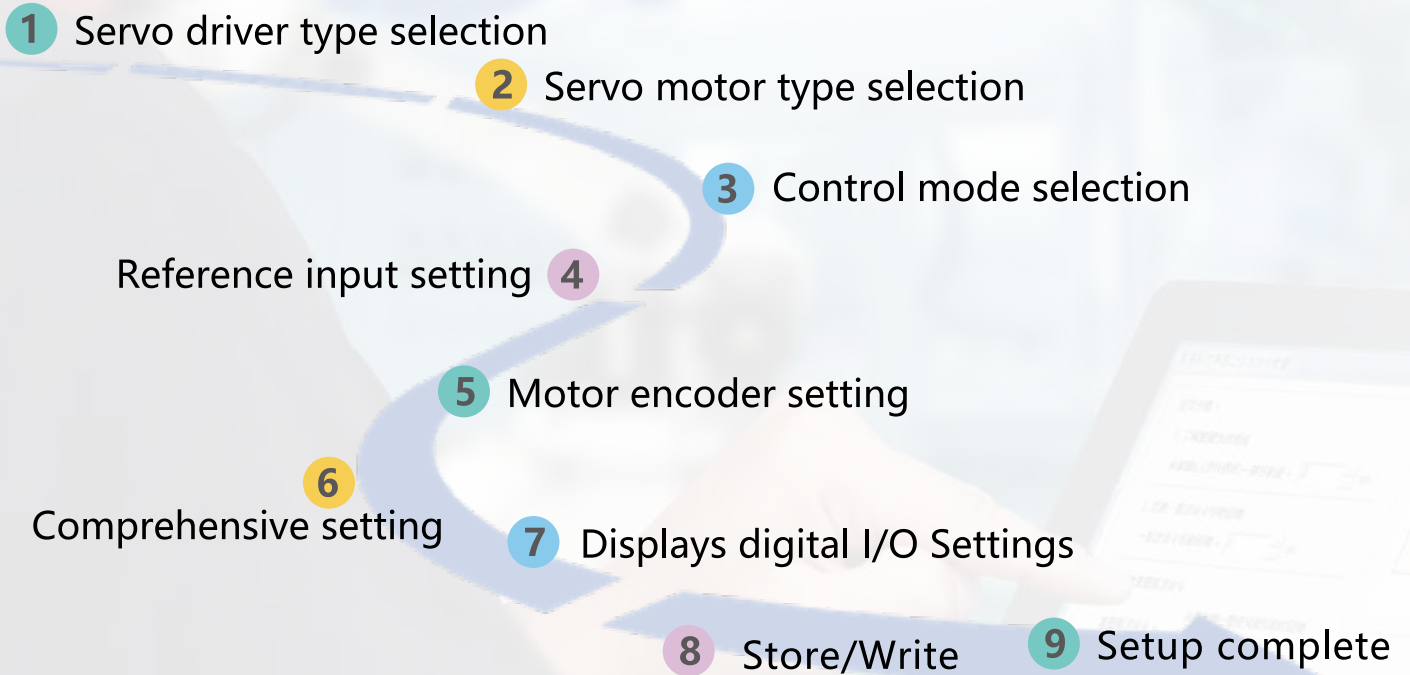

## Model selection

### Servo drive

JS D G3 - 15 A □

TECO AC Servo Driver Product Number

Driver

Driver Series:  
G3: G3 Series

Model (power) :

200V Model(A)	400V Model(B)
10 100W	10 750W
15 400W	15 1KW
20 750W	25 2KW
30 1KW	35 3KW
40 1.5KW	50 4.4KW
50 2KW	75 5.5KW
75 3KW	100 7.5KW

Optional model (communications)  
-E : EtherCAT  
□ : CANopen

Input Voltage:  
A: AC 200V Single-phase/Three-phase  
A3: AC 200V Three-phase  
B: AC 400V Three-phase

### Servo motor

JSMA - PUC 04 A 3 □ □

TECO AC Servo Driver Product Number

Servo Motor

A Series

IP67 Rating

Motor Rated Rotational Speed:  
A : 1000rpm  
H : 1500rpm  
B : 2000rpm  
C : 3000rpm

AC Input Voltage:  
A : AC200V  
B : AC400V

Encoder Specifications:  
7 : 17bit  
A : 17bit\*  
3 : 23bit  
W : 23bit\*  
\*Indicates ABS

Mechanical Brake:  
□ : No Brake  
B : With

Motor Inertia:  
S/U: Ultra low inertia  
L: Low Inertia  
M/I: Medium Inertia  
B/H/E: High Inertia

Motor Rated Power:

01 100W	10 1KW	29 2.9KW
02 200W	13 1.3KW	30 3.0KW
04 400W	15 1.5KW	44 4.4KW
08 750W	18 1.8KW	55 5.5KW
09 850W	20 2.0KW	75 7.5KW

	Key slot	Oil seal
□	No	No
K	Yes	No
O	No	Yes
A	Yes	Yes

## Motor product features

The G3 series is designed to work seamlessly with TECO's new JSMA series AC servo motors, now upgraded with high-resolution 23-bit encoders. A brand-new lineup of low, medium, and high inertia motors is also introduced, covering a wide power range from 100W to 7.5kW to meet diverse application needs.

The new motor series not only features high-resolution feedback but also brings significant performance enhancements. Maximum speed increased to 6,000 rpm (for models 750W and below).

Significantly shortened motor length for compact installation. Enhanced thermal design for reduced temperature rise cogging torque reduced to below 2%, ensuring high precision and smooth operation across various applications.

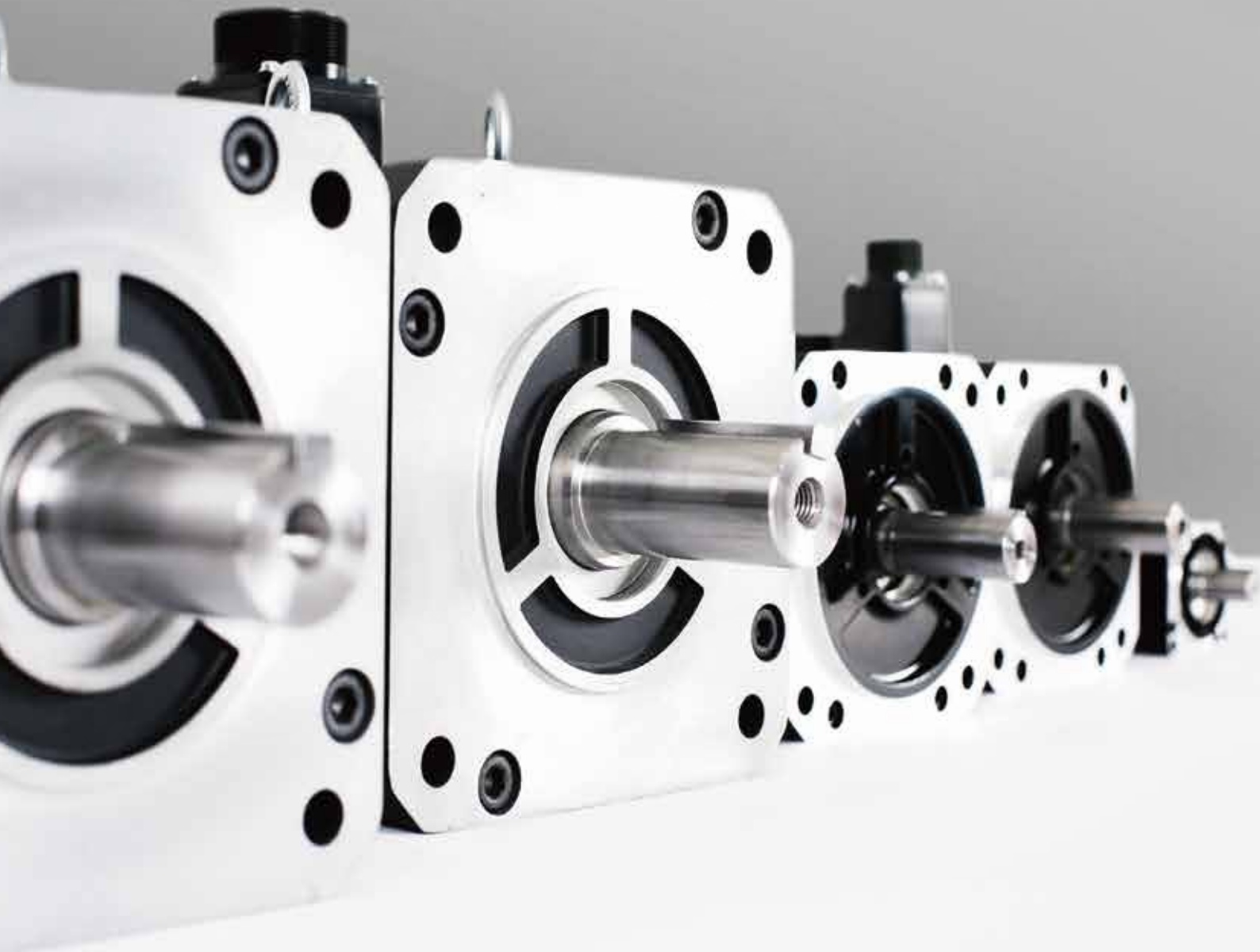

# Motor specification

## Ultra low/low inertia series

JSMA-P□□□□	Symbol	Unit	UC01	UC02	UC04	UC08	LC10	LC15	LC20
Rated output power	$P_R$	kW	0.1	0.2	0.4	0.75	1	1.5	2
Rated torque	$T_R$	N-m	0.32	0.64	1.27	2.39	3.18	4.77	6.37
Instantaneous maximum torque	$T_{max}$	N-m	0.95	1.91	3.81	7.16	9.55	14.3	19.1
Rated speed	$N_R$	rpm	3000						
Instantaneous maximum speed	$N_{max}$	rpm	6000	6000	6000	5000	5000	5000	5000
Torque constant	$K_T$	N-m/A	0.36	0.46	0.47	0.56	0.48	0.56	0.55
Rotor inertia	$J_M$	kg-cm <sup>2</sup>	0.041	0.17	0.28	0.9	2.1	3.0	4.07
Rotor inertia (with brakes)	$J_M$	kg-cm <sup>2</sup>	0.047	0.23	0.34	1.03	2.2	3.1	4.17
Motor impedance	$R_a$	$\Omega$	25.4	6.4	3.3	1.48	0.62/2 $\phi$	0.46/2 $\phi$	0.33/2 $\phi$
Motor reactance	$L_a$	mH	26.5	16.2	11	10.1	3.6/2 $\phi$	3.0/2 $\phi$	2.2/2 $\phi$
Weight (standard)	W	kg	0.48	1	1.37	2.4	3.5	4.5	5.5
Weight (with brakes)	W	kg	0.7	1.4	1.87	3.8	4.4	5.4	6.4
Insulation class	-	-	ClassF						
Operating temperature	T	°C	0 ~ 40						
Operating humidity	RH	%	< 80						
Storage temperature	T	°C	-20 ~ 60						
Storage humidity	RH	%	< 80						

## Medium inertia series

JSMA-P□□□□	Symbol	Unit	MB10	MB15	MB20	MB30	IH30	IH44	IH55	IH75
Rated output power	$P_R$	kW	1.0	1.5	2.0	3.0	3	4.4	5.5	7.5
Rated torque	$T_R$	N-m	4.77	7.16	9.55	14.32	19.1	28	35.1	47.8
Instantaneous maximum torque	$T_{max}$	N-m	14.31	21.48	28.65	42.96	47.75	70	87.75	122.6
Rated speed	$N_R$	rpm	2000	2000	2000	2000	1500	1500	1500	1500
Instantaneous maximum speed	$N_{max}$	rpm	2800	2800	2500	2500	2000	2000	2000	2000
Torque constant	$K_T$	N-m/A	1.02	1.06	1.14	1.13	1.19	1.19	1.19	1.24
Rotor inertia	$J_M$	kg-cm <sup>2</sup>	6.26	8.88	12.14	17.92	39.95	59.17	77.9	108.4
Rotor inertia (with brakes)	$J_M$	kg-cm <sup>2</sup>	6.96	9.58	12.84	18.62	42.36	61.58	80.31	110.88
Motor impedance	$R_a$	$\Omega$	1.22	0.79	0.58	0.33	0.275	0.167	0.129	0.1
Motor reactance	$L_a$	mH	6.7	4.7	3.8	2.1	6.8	4.3	3.2	2.5
Weight (standard)	W	kg	6.47	8.08	10.16	13.87	16.9	22.1	27.1	34.8
Weight (with brakes)	W	kg	8.08	9.69	11.7	15.48	21	26	31	39
Insulation class	-	-	ClassB				ClassF			
Operating temperature	T	°C	0 ~ 40							
Operating humidity	RH	%	< 80							
Storage temperature	T	°C	-20 ~ 60							
Storage humidity	RH	%	< 90				< 80			< 90

## High inertia series

JSMA-P□□□□	Symbol	Unit	BC01	BC02	BC04	BC08	BH09	BH13	BH18	BH29	BH44	BH55	BH75
Rated output power	$P_R$	kW	0.1	0.2	0.4	0.75	0.85	1.3	1.8	2.9	4.4	5.5	7.5
Rated torque	$T_R$	N-m	0.32	0.64	1.27	2.39	5.39	8.34	11.5	18.5	28.4	35	48
Instantaneous maximum torque	$T_{max}$	N-m	0.95	1.91	3.81	7.16	13.8	23.3	28.7	44.3	71.1	87.6	119
Rated speed	$N_R$	rpm	3000	3000	3000	3000	1500	1500	1500	1500	1500	1500	1500
Instantaneous maximum speed	$N_{max}$	rpm	6000	6000	6000	5000	3000	3000	3000	3000	3000	3000	3000
Torque constant	$K_T$	N-m/A	0.35	0.46	0.47	0.56	0.75	0.72	0.78	0.77	0.84	0.83	0.88
Rotor inertia	$J_M$	kg-cm <sup>2</sup>	0.082	0.42	0.67	1.51	13.34	20.07	26.66	45.55	65.41	89.98	129.8
Rotor inertia (with brakes)	$J_M$	kg-cm <sup>2</sup>	0.089	0.48	0.73	1.64	14.04	20.77	27.36	47.96	67.83	92.38	132.2
Motor impedance	$R_a$	$\Omega$	24	6.4	3.3	1.48	0.65	0.355	0.255	0.113	0.091	0.054	0.039
Motor reactance	$L_a$	mH	19.5	16.2	11	10.1	5.5	3.4	2.7	2.5	2.2	1.4	1.1
Weight (standard)	$W$	kg	0.48	1.1	1.53	2.7	6.7	8.9	11.1	18	23.5	30.5	41.2
Weight (with brakes)	$W$	kg	0.7	1.5	2.03	4.1	8.3	10.5	12.7	22.5	28	35	45.7
Insulation class	-	-	Class F										
Operating temperature	$T$	°C	0 ~ 40										
Operating humidity	RH	%	< 80										
Storage temperature	$T$	°C	-20 ~ 60										
Storage humidity	RH	%	< 80										

## Short body length, high inertia series

JSMA-P□□□□	Symbol	Unit	HC01	HC02	HC04	HC08	HH09	HH13	HH18	HH29	HH44	HH55	HH75	EC04	EC08
Rated output power	$P_R$	kW	0.1	0.2	0.4	0.75	0.85	1.3	1.8	2.9	4.4	5.5	7.5	0.4	0.75
Rated torque	$T_R$	N-m	0.32	0.64	1.27	2.39	5.39	8.34	11.5	18.6	28.4	35	48	1.27	2.39
Instantaneous maximum torque	$T_{max}$	N-m	0.954	1.92	3.81	7.17	14.2	23.3	28.7	45.1	71.1	87.6	119	4.45	8.37
Rated speed	$N_R$	rpm	3000	3000	3000	3000	1500	1500	1500	1500	1500	1500	1500	3000	3000
Instantaneous maximum speed	$N_{max}$	rpm	6000	6000	6000	5000	3000	3000	3000	3000	3000	3000	3000	6000	6000
Torque constant	$K_T$	N-m/A	0.289	0.41	0.551	0.619	0.89	0.89	0.76	1.7	1.93	1.8	1.92	0.53	0.51
Rotor inertia	$J_M$	kg-cm <sup>2</sup>	0.036	0.29	0.56	1.56	13.95	19.95	26.1	46	67.5	89	125	0.478	1.53
Rotor inertia (with brakes)	$J_M$	kg-cm <sup>2</sup>	0.037	0.31	0.58	1.66	16.1	22.1	28.1	53.9	75.4	97.5	133	0.54	1.66
Motor impedance	$R_a$	$\Omega$	13.97	8.55	6.8	1.78	1.06	0.62	0.32	0.62	0.47	0.28	0.17	3.26	1.43
Motor reactance	$L_a$	mH	23.83	16.85	14.93	7.3	8.1	4.98	2.77	8.53	6.95	4.52	3.45	9.4	5.53
Weight (standard)	$W$	kg	0.47	0.88	1.2	2.4	5.83	7.25	8.8	13	17.5	22	29.5	1.15	2.14
Weight (with brakes)	$W$	kg	0.67	1.18	1.52	2.8	7.8	9.24	10.76	19.5	24	27.8	35	1.6	3.54
Insulation class	-	-	Class F												
Operating temperature	$T$	°C	0 ~ 40												
Operating humidity	RH	%	< 80												
Storage temperature	$T$	°C	-20 ~ 60												
Storage humidity	RH	%	< 80												

# Motor TN curve

## Up to 80 frame series

— Intermittent Working Area | — Continuous Working Area

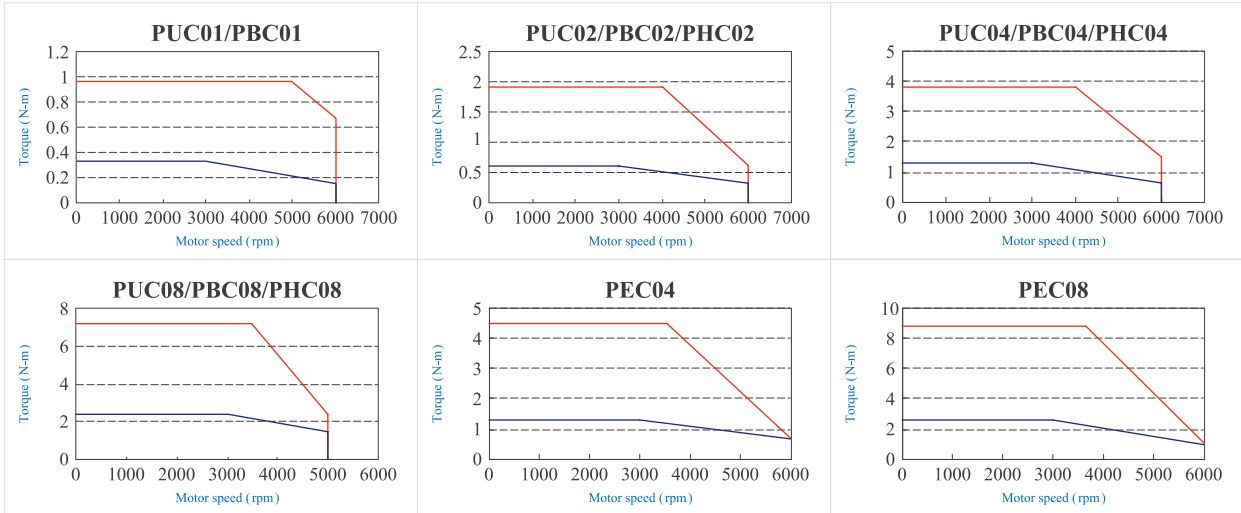

## Up to 130 frame series

— Intermittent Working Area | — Continuous Working Area

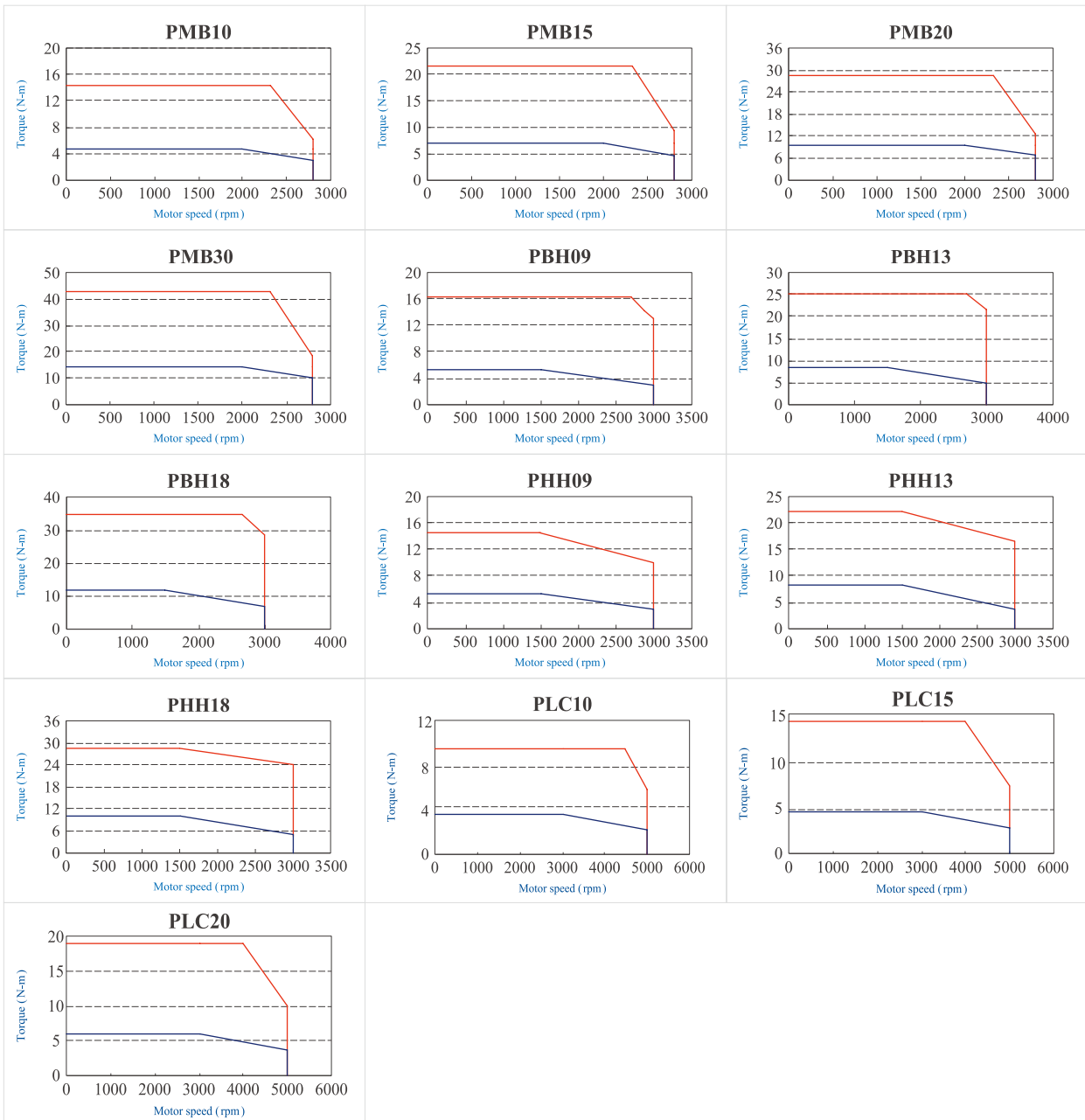

# Up to 180 frame series

— Intermittent Working Area | — Continuous Working Area

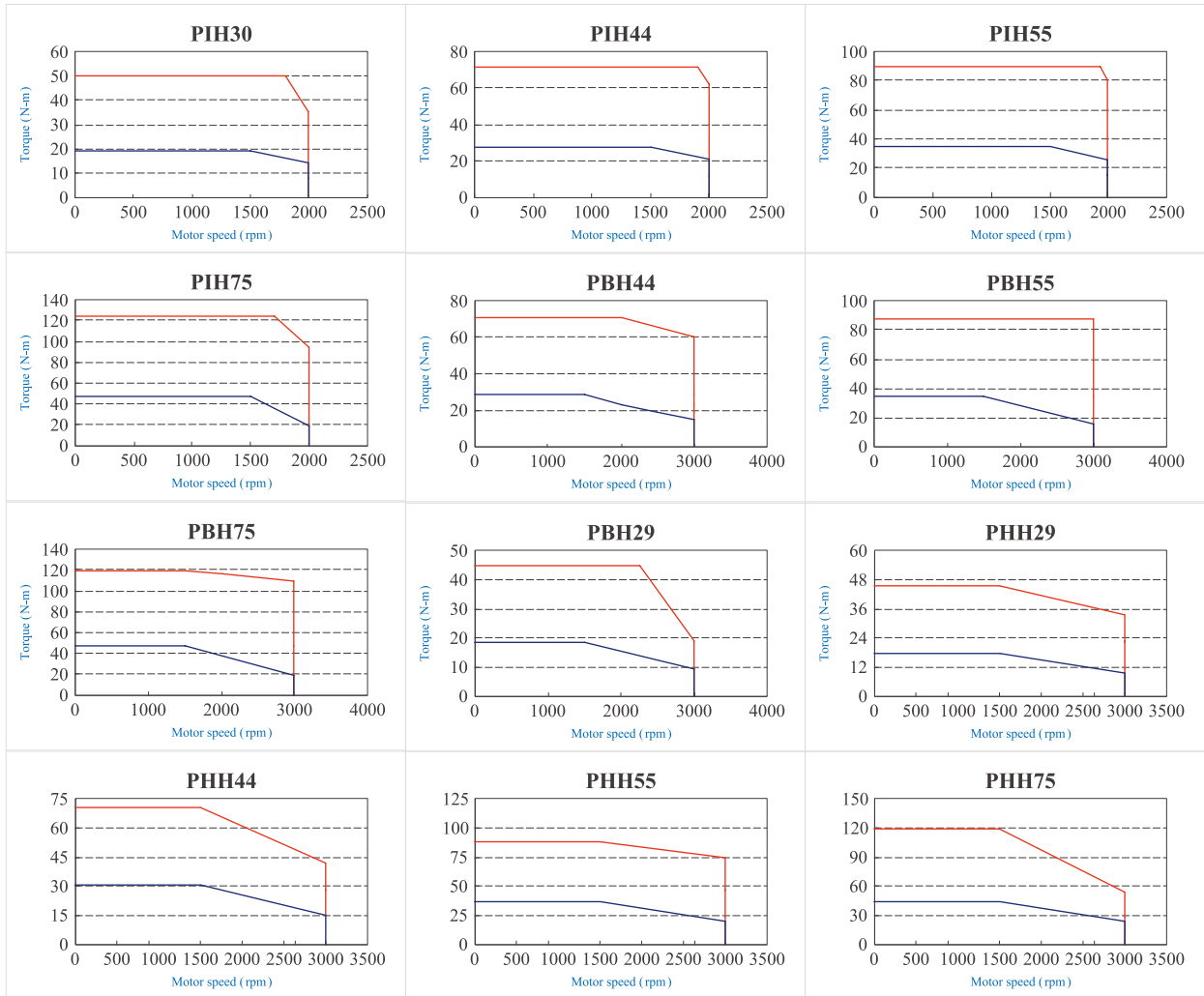

# Motor size drawing

Up to 80 frame series

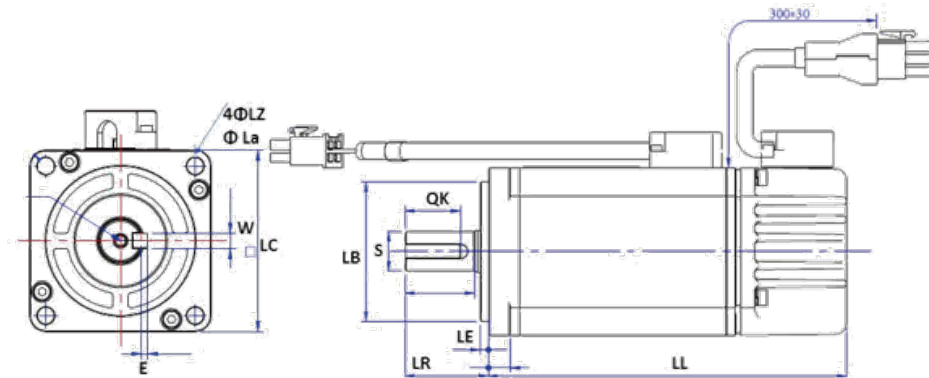

Up to 80 Frame Series JSMA-P□□□□	JSMA-PUC Series				JSMA-PBC Series				JSMA-PHC Series		
	UC01	UC02	UC04	UC08	BC01	BC02	BC04	BC08	HC02	HC04	HC08
LZΦ	Φ4.5	Φ5.5	Φ5.5	Φ6.5	Φ4.5	Φ5.5	Φ5.5	Φ6.5	Φ5.5	Φ5.5	Φ6.3
LaΦ	Φ46	Φ70	Φ70	Φ90	Φ46	Φ70	Φ70	Φ90	Φ70	Φ70	Φ90
LC	40	60	60	80	40	60	60	80	60	60	80
E	1.2	2	2	2.5	1.2	2	2	2.5	2	2	2.5
W	3	5	5	6	3	5	5	6	5	5	6
SΦ	Φ8	Φ14	Φ14	Φ19	Φ8	Φ14	Φ14	Φ19	Φ14	Φ14	Φ19
LBΦ	Φ30	Φ50	Φ50	Φ70	Φ30	Φ50	Φ50	Φ70	Φ50	Φ50	Φ70
QK	12.5	20	20	28	12.5	20	20	28	25	25	25
LE	2.5	3	3	3	2.5	3	3	3	3	3	3
LR	25	30	30	35	25	30	30	35	30	30	35
LL (No brakes)	88	101	123	122.2	86	106.5	128.5	137	93.7	110.7	122.4
LL (With brakes)	131.3	139.5	161.5	160.5	129.3	145	167	175.3	120.2	137.2	150.6

Up to 80 Frame Series JSMA-P□□□□	JSMA-PEC Series	
	EC04	EC08
LZΦ	Φ5.5	Φ6.5
LaΦ	Φ70	Φ90
LC	60	80
E	2	2.5
W	5	6
SΦ	Φ14	Φ19
LBΦ	Φ50	Φ70
QK	14	22
LE	3	3
LR	30	35
LL (No brakes)	96.1	107.7
LL (With brakes)	135.6	146.5

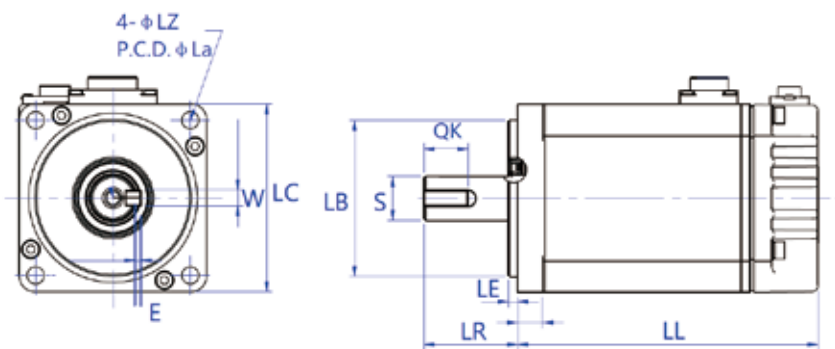

Up to 130 frame series

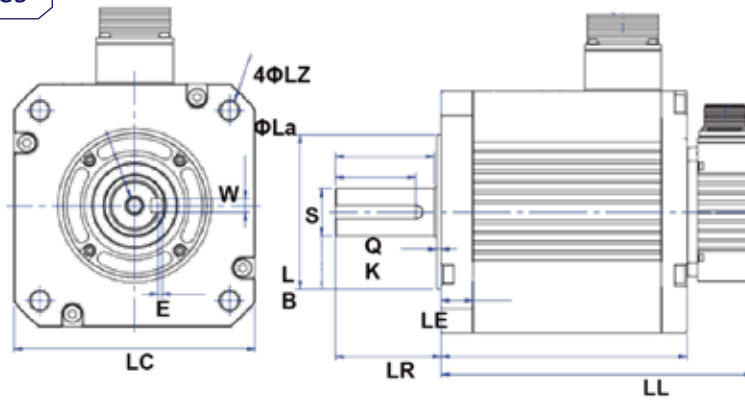

Up to 130 Frame Series JSMA-P□□□□	LC Series			MB Series				BH Series			HH Series		
	LC10	LC15	LC20	MB10	MB15	MB20	MB30	BH09	BH13	BH18	HH09	HH13	HH18
LZΦ	Φ9	Φ9	Φ9	Φ9	Φ9	Φ9	Φ9	Φ9	Φ9	Φ9	Φ9	Φ9	Φ9
LaΦ	Φ115	Φ115	Φ115	Φ145	Φ145	Φ145	Φ145	Φ145	Φ145	Φ145	Φ145	Φ145	Φ145
LC	100	100	100	130.4	130.4	130.4	130.4	130	130	130	130	130	130
E	2.5	2.5	2.5	2.5	2.5	2.5	2.5	2.5	2.5	2.5	2.5	2.5	2.5
W	6	6	6	6	6	6	6	6	6	6	6	6	6
SΦ	Φ19	Φ19	Φ19	Φ22	Φ22	Φ22	Φ22	Φ22	Φ22	Φ22	Φ22	Φ22	Φ22
LBΦ	Φ95	Φ95	Φ95	Φ110	Φ110	Φ110	Φ110	Φ110	Φ110	Φ110	Φ110	Φ110	Φ110
QK	42	42	42	35	35	35	35	35	35	35	28	28	28
LE	9	9	9	6	6	6	6	6	6	6	6	6	6
LR	55	55	55	58	58	58	58	58	58	58	58	58	58
LL (No brakes)	139	159	179	164.8	184.8	214.8	264.8	153.3	178.3	203.3	150.9	166.9	184.9
LL (With brakes)	179.5	199.5	219.5	219.3	239.3	268.3	318.3	195.9	220.9	245.9	183.4	199.4	217.4

Up to 130 frame series

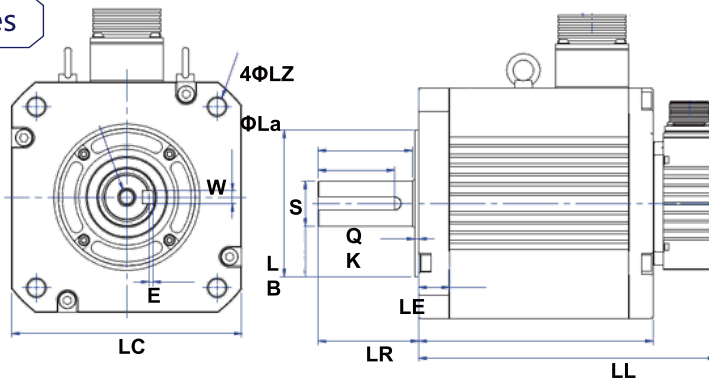

Up to 220 Frame Series JSMA-P□□□□	IH Series				BH Series				HH Series			
	IH30	IH44	IH55	IH75	BH29	BH44	BH55	BH75	HH29	HH44	HH55	HH75
LZΦ	Φ13.5	Φ13.5	Φ13.5	Φ13.5	Φ13.5	Φ13.5	Φ13.5	Φ13.5	Φ13.5	Φ13.5	Φ13.5	Φ13.5
LaΦ	Φ200	Φ200	Φ200	Φ200	Φ200	Φ200	Φ200	Φ200	Φ200	Φ200	Φ200	Φ200
LC	180	180	180	180	180	180	180	180	180	180	180	180
E	3	3	3	3	3	3	3	3	3	3	3	3
W	10	10	12	12	10	10	12	12	10	10	12	12
SΦ	Φ35	Φ35	Φ42	Φ42	Φ35	Φ35	Φ42	Φ42	Φ35	Φ35	Φ42	Φ42
LBΦ	Φ114.3	Φ114.3	Φ114.3	Φ114.3	Φ114.3	Φ114.3	Φ114.3	Φ114.3	Φ114.3	Φ114.3	Φ114.3	Φ114.3
QK	60	60	90	90	60	60	90	90	65	65	96	96
LE	3.2	3.2	3.2	3.2	3.2	3.2	3.2	3.2	3.2	3.2	3.2	3.2
LR	79	79	113	113	79	79	113	113	79	79	113	113
LL (No brakes)	192.4	222.4	249.9	307.4	201.4	233.4	269.4	343.4	173.3	197.3	236.3	282.3
LL (With brakes)	244.6	274.6	302.1	359.6	253.6	285.6	321.6	395.6	231	255	278	324

# System assembly and wiring 220V

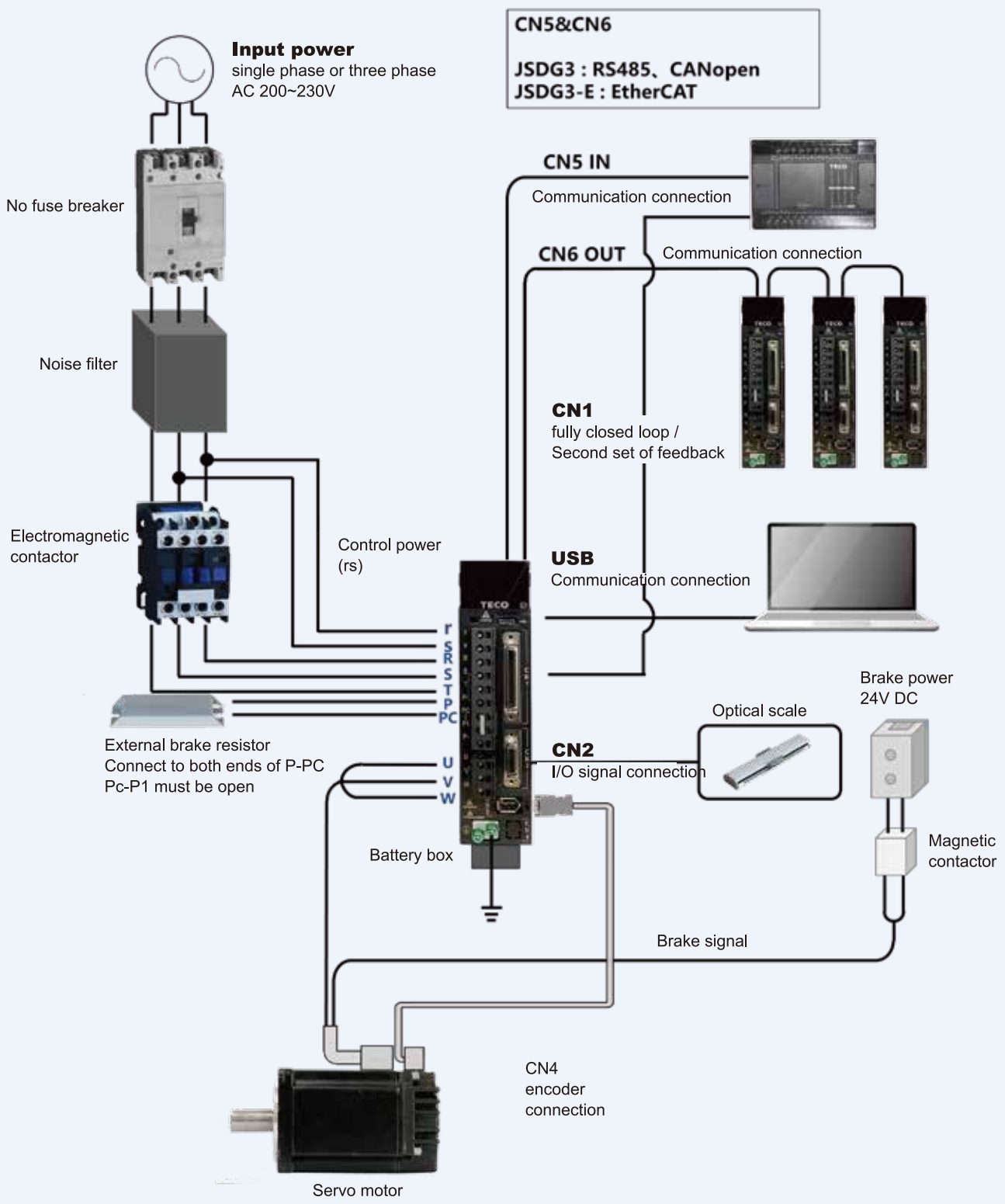

# System assembly and wiring 380V

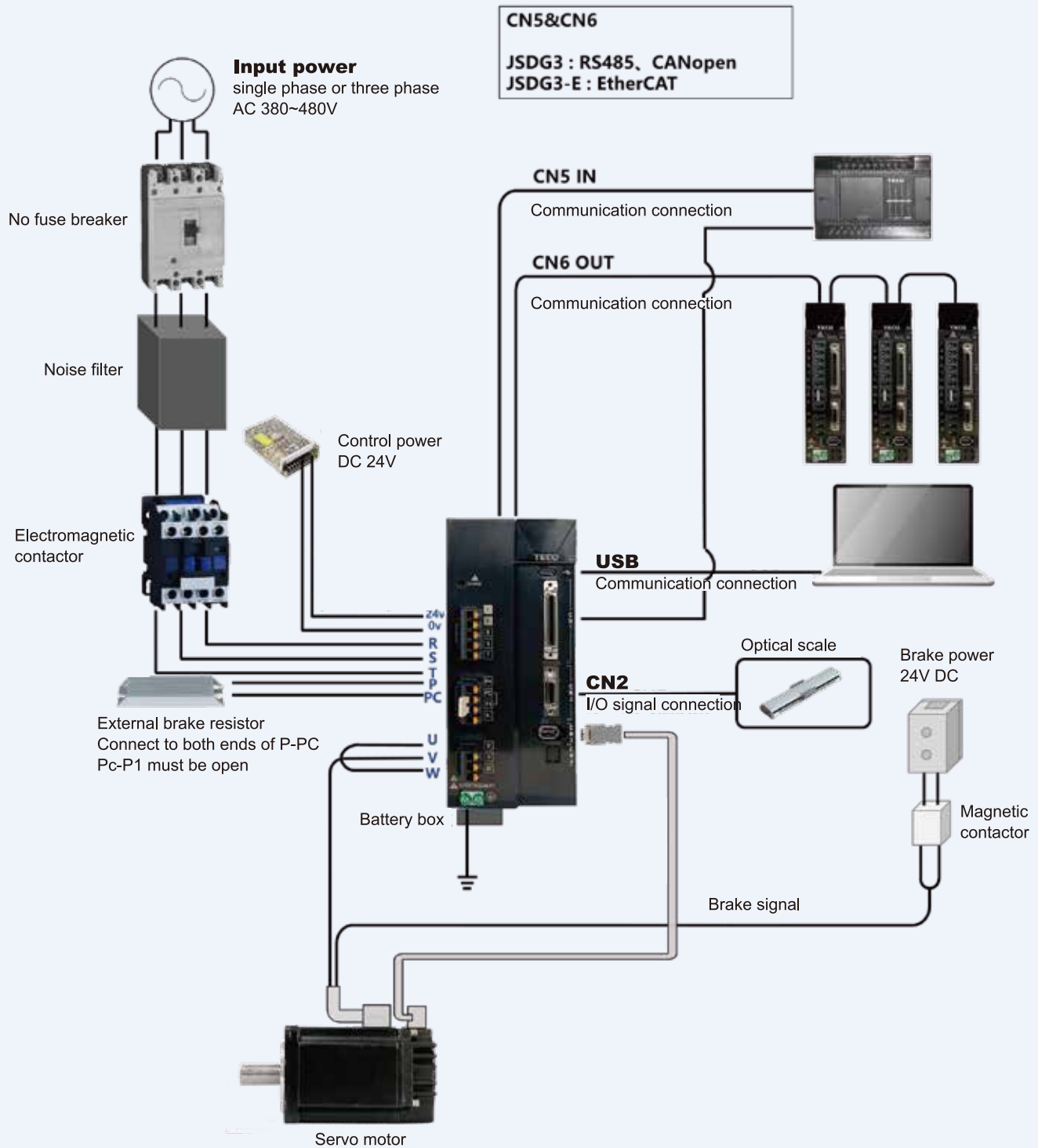

# Drive specification

Servo drive model JSDG3-□□□□		200V Class							400V Class							
		10A	15A	20A	30A	40A	50A3	75A3	10B	15B	25B	35B	50B	75B	100B	
Basic specification	Servo motor Capacity [KW]		0.1	0.4	0.75	1.0	1.5	2.0	3.0	0.75	1.0	1.5	2.0	3.0	4.5/5.5	7.5
	Continuous output current [Arms]		2.1	3.5	4.4	5.6	7.5	9.2	14	2.0	2.6	6.0	8.0	11.5	16.0	T.B.D
	Maximum output current [Arms]		5.7	8.5	11.3	17	22.6	28.3	42.4	5.7	6.8	15.6	20.8	29.9	41.6	T.B.D
	Input current	Main loop R.S.T	Single phase or three phase AC170 ~ 253V					three phase AC170 ~ 253V		three phase AC380 ~ 480V, ±10%						
	Cooling method		Natural cooling		Fan cooling					Fan cooling						
	Control method		Three-phase full-wave rectification IGBT PWM control (sinusoidal current drive)													
Internal function	Encoder resolution		17bit/23bit (incremental or absolute)													
	Display and operation		Main/control loop power indicator; Five-bit seven-segment display; Four functional operation keys													
	Control mode		Position (external pulse command), position (internal position command), speed, torque, dual mode switching (position/speed, speed/torque, position/torque)													
	Regenerative brake		Built-in brake crystal and brake resistance/can be connected to the external brake resistance													
	Protective function		Multiple abnormal alarm warnings													
	Communication interface		CANopen (standard)/EtherCAT (optional)													
Position control mode	Command control method		External command pulse commands/32 groups of internal temporary commands													
	External instruction pulse input	Wave mode	Differential input: direction + pulse, CCW+CW pulse, phase difference pulse (phase A + phase B)													
		Wave form	Line drive (line drive+5V level), open collector (+5~+24V)													
		Maximum frequency	4Mpps (line drive)/200Kpps (open collector)													
	Electronic gear ratio		1/1000 ≤ electronic gear ratio ≤ 32000													
	Instruction smoothing mode		Smoothing time constant: 0 ~ 10 sec													
	Position completion judgment		0 ~ 41943040 pulse													
Feedforward gain compensation		0 ~ 100%														
Speed control mode	Origin resetting function		Internal parameter setting													
	Command control mode		External emulation command/three-segment internal speed command													
	External instruction pulse input	Voltage range	0 ~ ±10Vdc/0 ~ 6000rpm (internal parameter settings)													
		Input impedance	10KΩ													
	Speed control range		1:500 (internal speed command)/1:2000 (external simulation command)													
	Rate of velocity variation		Load variation rate: 0~100% ±0.03% below (at rated speed)													
			Voltage variation rate: ±10% ±0.2% or less (at rated speed)													
			Temperature variation rate: 0 ~ 50°C ±0.5% below (at rated speed)													
	Instruction smoothing mode		Linear time constant: 0 ~ 50sec; S-type time constant: 0 ~ 5sec; Smoothing time constant: 0 ~ 10sec													
	Frequency characteristic		1.5KHz (when JL=JM)													
Torque limitation		External simulation command/internal parameter setting														
Zero speed decision/speed arrival decision		0 ~ 6000rpm (internal parameter setting)														
Torque control mode	Command control mode		External simulation command													
	without Simulation command	Voltage range	0 ~ ±10Vdc/0 ~ 300%													
		Input impedance	10KΩ													
	Instruction smoothing mode		Linear time constant: 0 ~ 50sec, smooth time constant: 0 ~ 10sec													
	Speed limit		External simulation command/internal parameter setting													
The torque reaches the judgment		0 ~ 300% (internal parameter setting)														
Input/output signal	Position output	Output pattern	A, B, Z phase line drive output/Z phase open collector output													
		Periodic ratio	Pulse output 1 ~ encoder - pulse wave number ÷ 4 (internal parameters can be set at any position)													
	Digital input [NPN/PNP]	Twelve points can be arbitrarily planned	Servo start, abnormal alarm clear, P/PI switch, CCW/CW direction drive disable, external torque limit pulse error clear, servo lock, emergency stop, internal speed command selection, control mode switching, position command prohibition, gain switching, electronic gear ratio molecular selection, internal position command trigger, internal position command pause, start back to origin, external reference origin, internal position command selection...etc.													
	Digital output [Photocoupler]	Eight points can be arbitrarily planned	Servo abnormal alarm code, paction, torque limit, drive disable, base block. Servo ready complete, servo abnormal, zero speed signal, mechanical brake signal, speed arrival signal, positioning complete signal, origin return complete signal, torque reached output completion signal... Wait for 17 signals.													
Analog monitor output	Eight points can be arbitrarily planned	Speed feedback detection, torque/speed instruction/pulse input instruction/position offset, electrical angle, main loop (Vdc bus) voltage...etc.														
Environment	Installation site		Indoor (avoid direct sunlight), non-corrosive fog (avoid oil smoke, flammable gas dust)													
	Elevation		Below 1000M above sea level													
	Temperature		Operating temperature: 0 ~ 50°C; Storage temperature: -20°C ~ +85°C													
	Humidness		Less than 95% RH (no condensation)													
Safety regulation	Vibration		0 ~ 57Hz: 20m/s <sup>2</sup> ; 57Hz to 150Hz: 2 Mbit/s													
	CE declaration		In accordance with EN61800-3 and EN61800-5-1													
	UL certification		N/A													

## Servo size

### JSDG3-10A/15A (-E) (200V Class)

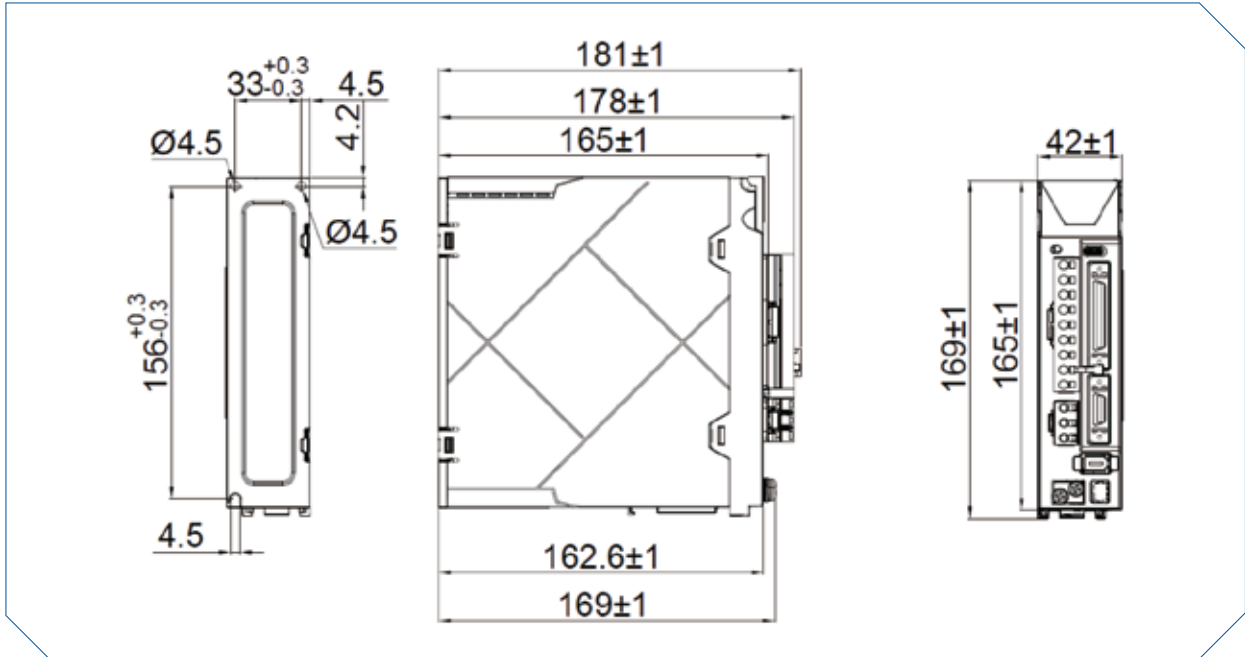

### JSDG3-20A/30A/40A (-E) (200V Class)

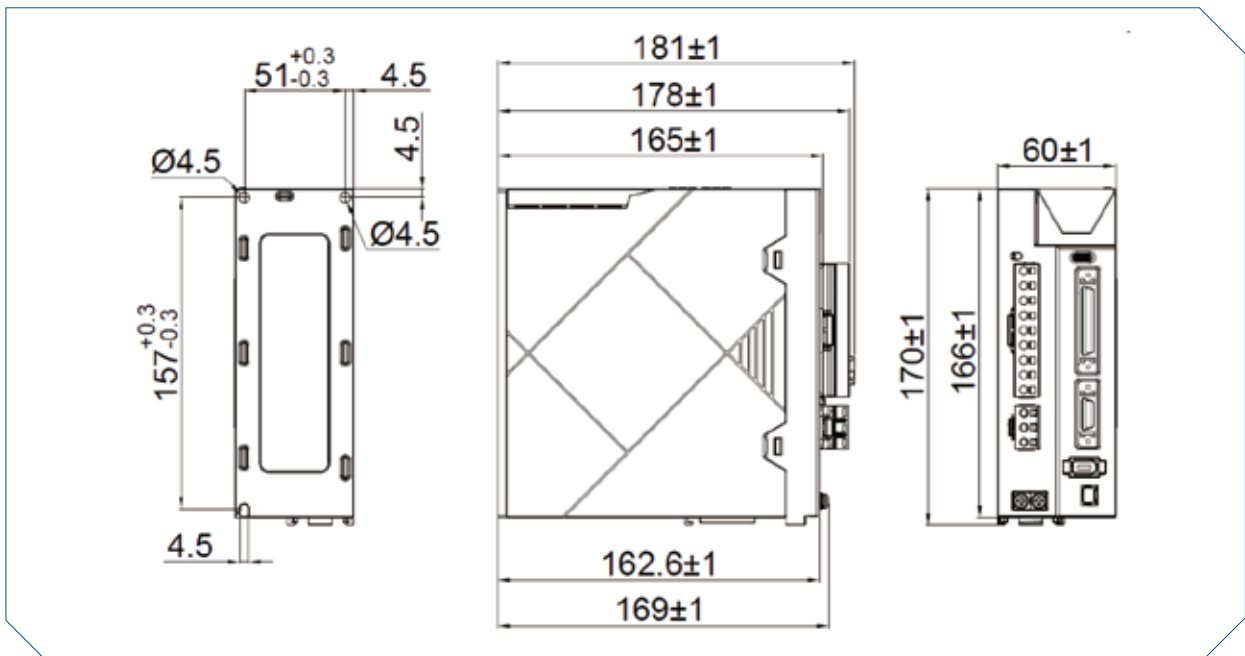

JSDG3-50A3/75A3 (-E) (200V Class)  
 JSDG3-10B/15B/25B/35B (-E) (400V Class)

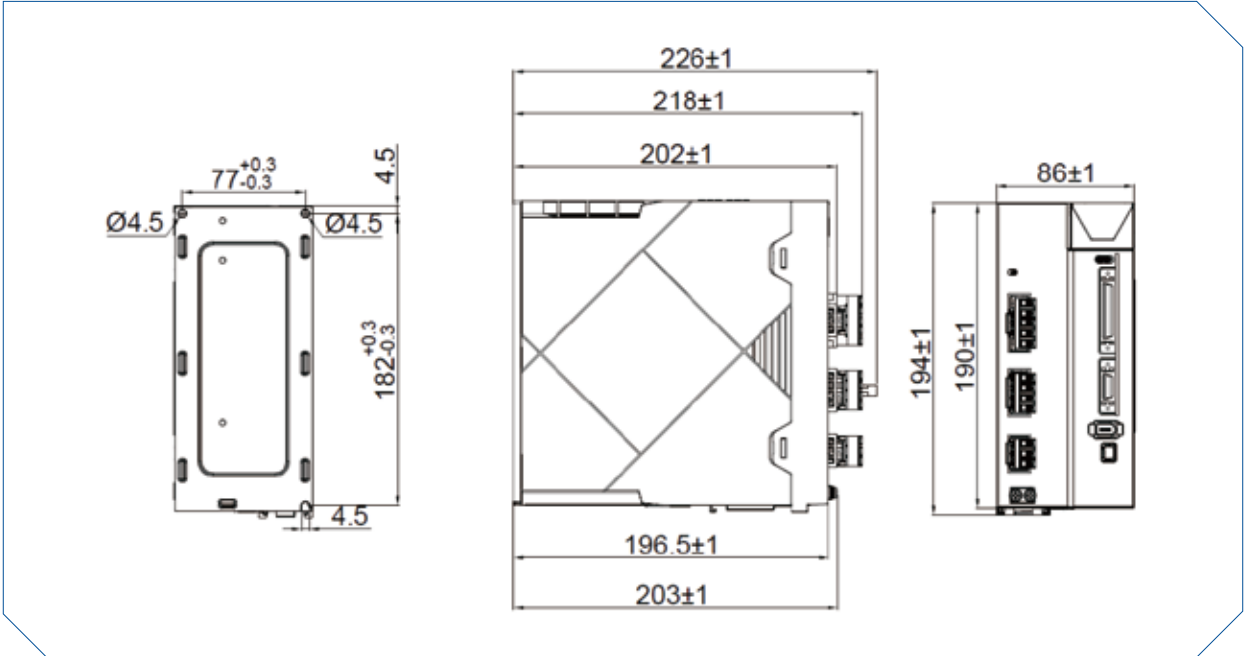

JSDG3-50B/75B (-E) (400V Class)

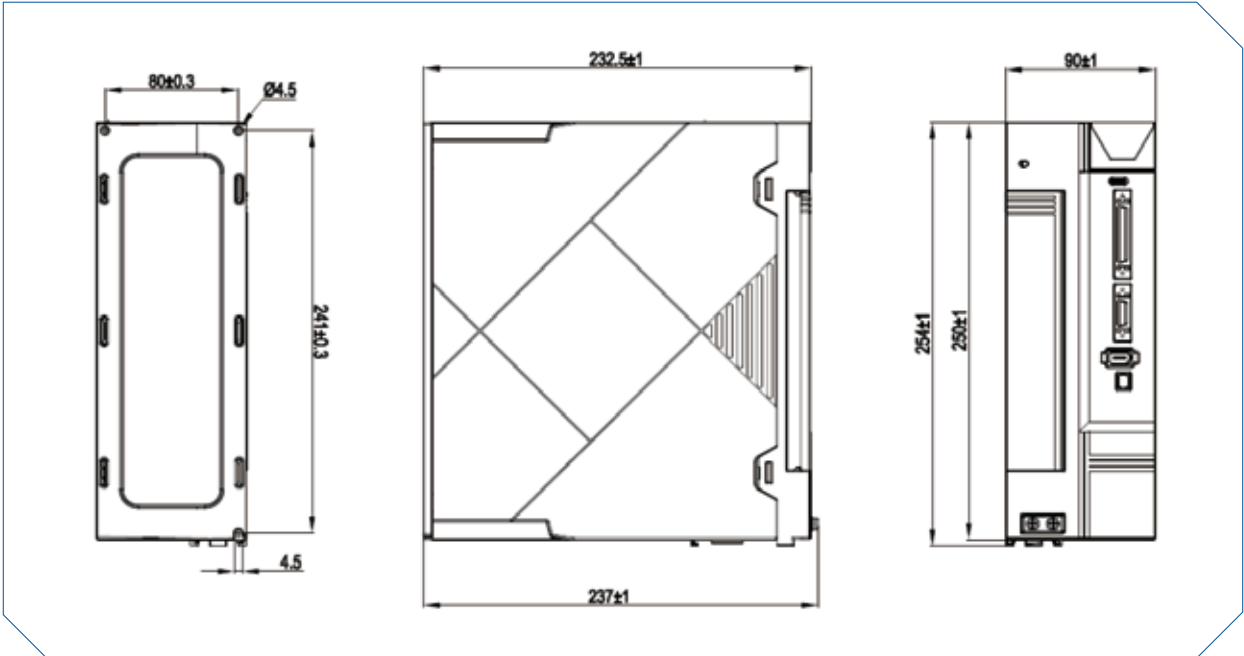

# Servo drive accessories

## Motor power trunk

With UC/BC/HC series motors

No.	Length(m)
JSSLM003	3
JSSLM005	5
JSSLM010	10
JSSLM015	15
JSSLM020	20

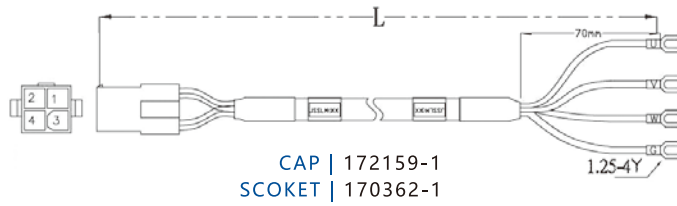

With LC/MB/BH09/BH13/BH18 series motors

No.	Length(m)
JSSMLM003	3
JSSMLM005	5
JSSMLM010	10
JSSMLM015	15
JSSMLM020	20

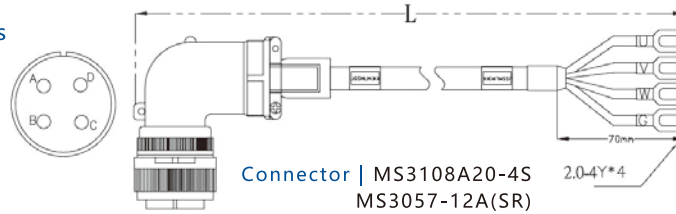

With LC/MA/MB/MC/BH09~BH18 series motors

No.	Length(m)
JSSMLMP001	1
JSSMLMP003	3
JSSMLMP005	5
JSSMLMP010	10

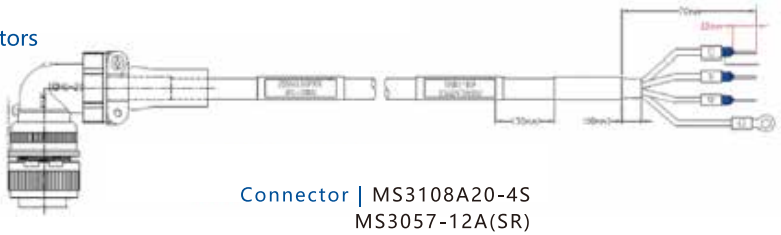

With IH30/IH44 series motors

No.	Length(m)
JSSBLM003	3
JSSBLM005	5
JSSBLM010	10
JSSBLM015	15
JSSBLM020	20

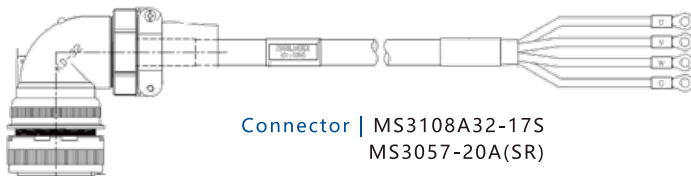

With IH55/IH75/BH44/BH55 series motors

No.	Length(m)
JSSBLM003B	3
JSSBLM005B	5
JSSBLM010B	10
JSSBLM015B	15
JSSBLM020B	20

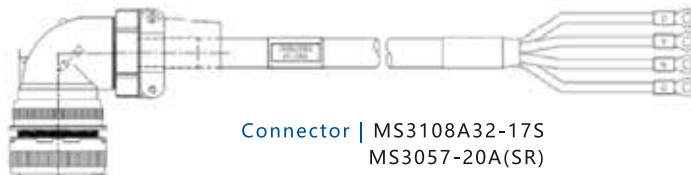

With the BH29 series motor

No.	Length(m)
JSSILM003	3
JSSILM005	5
JSSILM010	10
JSSILM015	15
JSSILM020	20



Note: Please consult the local business personnel for PHH series motor accessories.

## Motor power joint

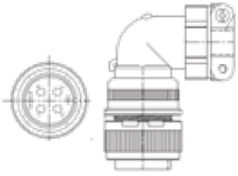

**JSSCNML04**

Connector

MS3108A20-4S MS3057-12A(SR)

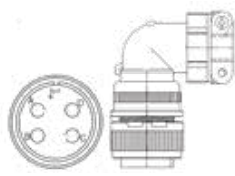

**JSSCNBL04**

Connector

MS3108A32-17S MS3057-20A(SR)

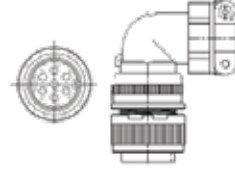

**JSSCNPL07**

(Connector with brake contact)

Connector

MS310820-15S MS3057-12A(SR)

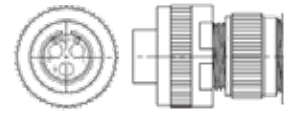

**JSSCNBL03**

(Brake connector)

Connector

MS3106A105L-3S MS3057-4A(SR)

## Encoder trunk

With UC/BC/LC03~08 series motors

No.	Length(m)
JSSL2XLG001	1
JSSL2XLG003	3
JSSL2XLG005	5
JSSL2XLG010	10



Connector | 172161-1  
Terminal | 170361-1

Connector | Molex 551000670

With MA/MB/MC/BH/IH series motors

No.	Length(m)
JSSL2XMLG001	1
JSSL2XMLG003	3
JSSL2XMLG005	5
JSSL2XMLG010	10



Connector | MS3108A20-18S  
MS3057-12A(SR)

Connector | Molex 551000670

## Encoder adapter

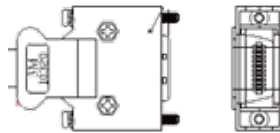

**JSSCN20P**

Connector

MS3108A20-18S MS3057-12A(SR)

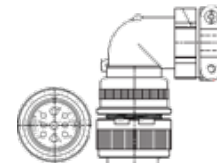

**JSSCNPL09**

Connector

10320-52A0-008 10120-3000PE

## CN1 connector

No.
JSSCN50P

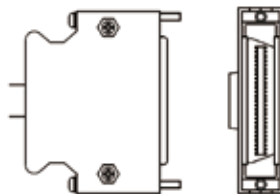

## Battery kit

No.
JSSMDBAT01



## 220V drive accessories selection table

Motor series	Capacity (W)	Motor model	Collocation driver	CN1 connector	Incremental encoder cable	Absolute value encoder cable	3m power line
PUC series Ultra-low inertia Small capacity 3000rpm	100W	PUC01A7□□	JSDG3-10A	JSSCN50P	JSSL2XLG003	JSSL2XLG003	JSSLM003
	200W	PUC02A7□□	JSDG3-15A	JSSCN50P	JSSL2XLG003	JSSL2XLG003	JSSLM003
	400W	PUC04A7□□	JSDG3-15A	JSSCN50P	JSSL2XLG003	JSSL2XLG003	JSSLM003
	750W	PUC08A7□□	JSDG3-20A	JSSCN50P	JSSL2XLG003	JSSL2XLG003	JSSLM003
	1kW	PUC10A7□□	JSDG3-30A	JSSCN50P	JSSL2XLG003	JSSL2XLG003	JSSLM003
PBC series High inertia Small capacity 3000rpm	100W	PBC01A7□□	JSDG3-10A	JSSCN50P	JSSL2XLG003	JSSL2XLG003	JSSLM003
	200W	PBC02A7□□	JSDG3-10A	JSSCN50P	JSSL2XLG003	JSSL2XLG003	JSSLM003
	400W	PBC04A7□□	JSDG3-15A	JSSCN50P	JSSL2XLG003	JSSL2XLG003	JSSLM003
	750W	PBC08A7□□	JSDG3-20A	JSSCN50P	JSSL2XLG003	JSSL2XLG003	JSSLM003

Note: Motors with brakes below 750W are matched with the same power line, please refer to the complete manual for details.

Motor Series	Capacity (W)	Motor Model	Collocation Driver	CN1 Connector	Incremental Encoder Cable	Absolute value encoder cable	3m power line	Power line sub (including brake)
PLC series Low inertia Small capacity 3000rpm	1KW	PLC10A7□□	JSDG3-30A	JSSCN50P	JSSL2XLG003	JSSL2XLG003	JSSMLM003	JSSCNPL07
	1.5KW	PLC15A7□□	JSDG3-40A	JSSCN50P	JSSL2XLG003	JSSL2XLG003	JSSMLM003	JSSCNPL07
	2KW	PLC20A7□□	JSDG3-50A3	JSSCN50P	JSSL2XLG003	JSSL2XLG003	JSSMLM003	JSSCNPL07
PMB Series Medium inertia Medium capacity 2000rpm	1KW	PMB10A7□□	JSDG3-30A	JSSCN50P	JSSL2XMLG003	JSSL2XMLG003	JSSMLM003	JSSCNPL07
	1.5KW	PMB15A7□□	JSDG3-40A	JSSCN50P	JSSL2XMLG003	JSSL2XMLG003	JSSMLM003	JSSCNPL07
	2KW	PMB20A7□□	JSDG3-50A3	JSSCN50P	JSSL2XMLG003	JSSL2XMLG003	JSSMLM003	JSSCNPL07
	3KW	PMB30A7□□	JSDG3-75A3	JSSCN50P	JSSL2XMLG003	JSSL2XMLG003	JSSMLM003	JSSCNPL07
PBH Series High inertia Medium capacity 1500rpm	0.85KW	PBH09A7□□	JSDG3-30A	JSSCN50P	JSSL2XMLG003	JSSL2XMLG003	JSSMLM003	JSSCNPL07
	1.3KW	PBH13A7□□	JSDG3-50A3	JSSCN50P	JSSL2XMLG003	JSSL2XMLG003	JSSMLM003	JSSCNPL07
	1.8KW	PBH18A7□□	JSDG3-75A3	JSSCN50P	JSSL2XMLG003	JSSL2XMLG003	JSSMLM003	JSSCNPL07

Note: PLC/PMB/PBH series motors (130 flanges), if you buy brake joints, you do not need to buy power lines.

### 380V drive accessories selection table

Motor series	Capacity (W)	Motor model	Collocation driver	CN1 connector	Incremental encoder cable	Absolute value encoder cable	3m power line
PUC series Ultra-low inertia Small capacity 3000rpm	400W	PUC04B7□□	JSDG3-10B	JSSCN50P	JSSL2XLG003	JSSL2XLG003	JSSLM003
	750W	PUC08B7□□	JSDG3-15B	JSSCN50P	JSSL2XLG003	JSSL2XLG003	JSSLM003
PBC series High inertia Small capacity 3000rpm	400W	PBC04B7□□	JSDG3-10B	JSSCN50P	JSSL2XLG003	JSSL2XLG003	JSSLM003
	750W	PBC08B7□□	JSDG3-15B	JSSCN50P	JSSL2XLG003	JSSL2XLG003	JSSLM003

Note: Motors with brakes below 750W are matched with the same power line, please refer to the complete manual for details.

Motor series	Capacity (W)	Motor model	Collocation driver	CN1 connector	Incremental encoder cable	Absolute value encoder cable	3m power line	Power line sub (including brake)
PMB series Medium inertia Medium capacity 2000rpm	1KW	PMB10B7□□	JSDG3-15B	JSSCN50P	JSSL2XMLG003	JSSL2XMLG003	JSSMLM003	JSSCNPL07
	1.5KW	PMB15B7□□	JSDG3-25B	JSSCN50P	JSSL2XMLG003	JSSL2XMLG003	JSSMLM003	JSSCNPL07
	2KW	PMB20B7□□	JSDG3-35B	JSSCN50P	JSSL2XMLG003	JSSL2XMLG003	JSSMLM003	JSSCNPL07
	3KW	PMB30B7□□	JSDG3-50B	JSSCN50P	JSSL2XMLG003	JSSL2XMLG003	JSSMLM003	JSSCNPL07
PBH series High inertia Medium capacity 1500rpm	0.85KW	PBH09B7□□	JSDG3-15B	JSSCN50P	JSSL2XMLG003	JSSL2XMLG003	JSSMLM003	JSSCNPL07
	1.3KW	PBH13B7□□	JSDG3-25B	JSSCN50P	JSSL2XMLG003	JSSL2XMLG003	JSSMLM003	JSSCNPL07
	1.8KW	PBH18B7□□	JSDG3-35B	JSSCN50P	JSSL2XMLG003	JSSL2XMLG003	JSSMLM003	JSSCNPL07
	2.9KW	PBH29BA□□	JSDG3-50B	JSSCN50P	JSSL2XMLG003	JSSL2XMLG003	JSSILM003	JSSCNBL03
	4.4KW	PBH44BA□□	JSDG3-75B	JSSCN50P	JSSL2XMLG003	JSSL2XMLG003	JSSBLM003	JSSCNBL03
	5.5KW	PBH55BA□□	JSDG3-100B	JSSCN50P	JSSL2XMLG003	JSSL2XMLG003	JSSBLM003B	JSSCNBL03
PIH series Medium inertia Medium capacity 1500rpm	3KW	PIH30BA□□	JSDG3-50B	JSSCN50P	JSSL2XMLG003	JSSL2XMLG003	JSSBLM003	JSSCNBL03
	4.4KW	PIH44BA□□	JSDG3-75B	JSSCN50P	JSSL2XMLG003	JSSL2XMLG003	JSSBLM003	JSSCNBL03
	5.5KW	PIH55BA□□	JSDG3-75B	JSSCN50P	JSSL2XMLG003	JSSL2XMLG003	JSSBLM003B	JSSCNBL03
	7.5KW	PIH75BA□□	JSDG3-100B	JSSCN50P	JSSL2XMLG003	JSSL2XMLG003	JSSBLM003B	JSSCNBL03

Note: PMB/PBH series motors (130 flanges), if you buy brake joints, you do not need to buy power lines.



**TECO** | TECO Electric & Machinery Co., Ltd.

Address: 10F., No. 3-1, Park St., Nangang Dist., Taipei City 115603, Taiwan

Tel: +886-2-6615-9111 Web: [www.teco.com.tw](http://www.teco.com.tw)